

ISS.	AMEND	DATE
1	ISSUED	16/02/18

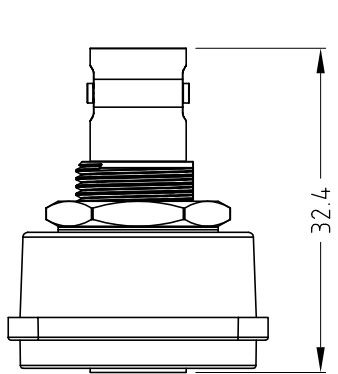

32.4

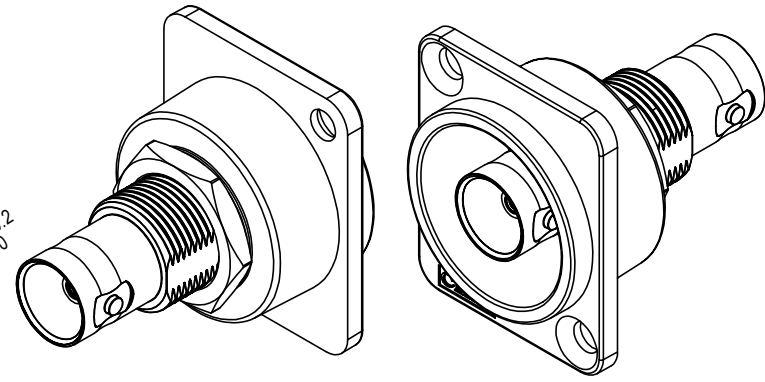
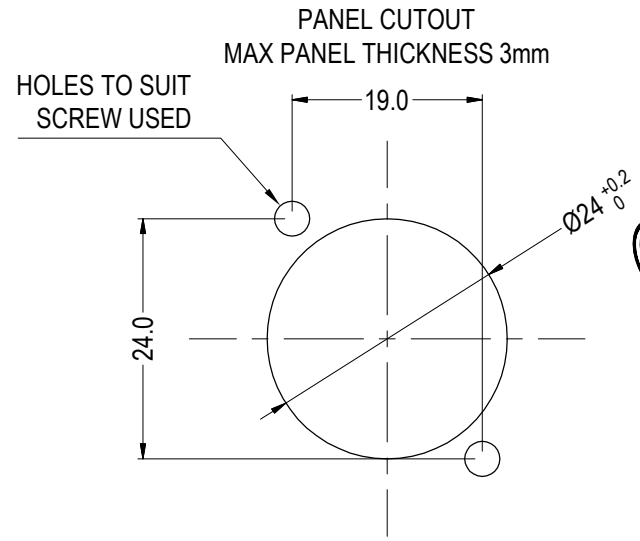

ITEM	DESCRIPTION	MATERIAL	FINISH
1	FRAME	POLYAMIDE UL94 V2	BLACK
2	NUT	BRASS	NICKEL
3	WASHER	BRASS	NICKEL
4	BNC	ALLOY	NICKEL
5	BNC INSULATION	POM	BLACK

CP303095 - CSK HOLES

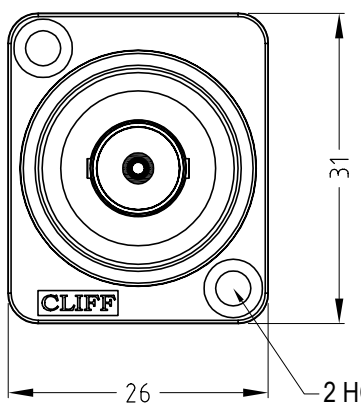

2 HOLES: Ø3.50 CSK 82° x Ø5.85
'X' VERSION HAS Ø2.50 HOLES.

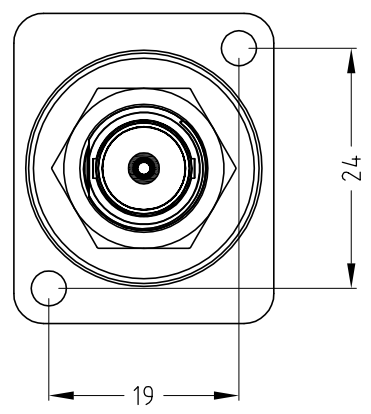
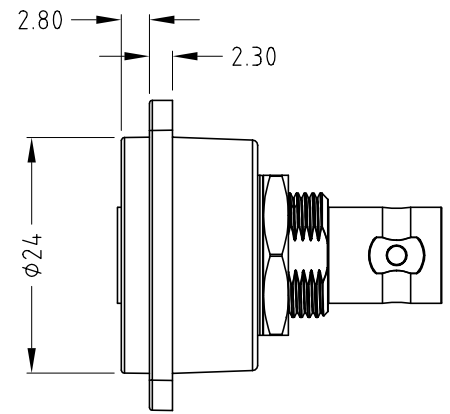

VARIANTS	
PART NO.	HOLE DETAILS
CP303095	HOLE Ø3.50xCSK 82°x Ø5.85
CP303095X	PLAIN HOLE Ø2.50

CP303095X - Ø2.50 PLAIN HOLES

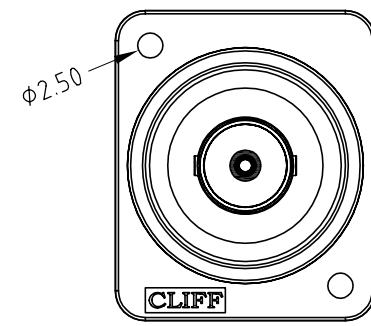

RoHS
✓ **COMPLIANT**

TOLERANCE
NO DEC. PLACE ±
1 DEC. PLACE ±
2 DEC. PLACE ±
HOLE Ø ±
ANGLES ±
UNLESS OTHERWISE STATED

DO NOT SCALE

Cliff Electronic Components Ltd.
76 Holmetherpe Avenue, Holmetherpe Industrial Estate,
Redhill, Surrey, RH1 2PF, England, UK
Tel: 01737-771375 Fax: 01737-766012 Website: www.cliffuk.co.uk

DIMENSIONS IN MILLIMETERS UNLESS OTHERWISE STATED. WORK TO DIMENSIONS. REMOVE ALL BURRS. IF IN DOUBT ASK.

3rd ANGLE PROJECTION:

MATERIAL: SEE TABLE
FINISH: SEE TABLE

TITLE: XRP12 BNC 75 OHM

THE CONTENTS OF THIS DOCUMENT MUST NOT BE COPIED OR DISCLOSED TO A 3rd PARTY WITHOUT WRITTEN PERMISSION OF CLIFF UK. © 2018

DRAWN: T.J.O.

APPROVED: D.P.J.

DRWG. No. **CP303095**

FORM: A4DRWGH