

- Notes
- The dimension in parentheses are for reference.
  - Lead co-planarity including reinforced metal fittings shall be 0.1 max.
  - To be delivered with tape and reel packaging. See attached packaging specification for details.
  - Note that preventive hole for sink mark, lighting hole, or slit could be added for improvement.
  - The quality remains good, even with the dark spots, which could occasionally occur on molded plastic.
  - This product satisfies halogen free requirements defined as 900 ppm maximum chlorine, 900 ppm maximum bromine and 1500 ppm maximum total of chlorine and bromine.
  - 'n' represents the number of contacts.

4	Copper alloy	Tin plating (reflow finished) 1μm MIN and copper (interlayer) & 15μm MIN over nickel 1μm MIN	9	(Connector)	
3	Copper alloy	Contact area lead: Gold plating 0.03μm MIN over nickel 1μm MIN. Other: Nickel plating 1μm MIN.	8	Polystyrene	
2	LCP	BLACK UL94V-0	7	Polyester	
1	LCP	GLAY UL94V-0	6	Polystyrene	
			5	Stainless steel	
				Tin plating (reflow finished) 1μm MIN over nickel 0.2μm MIN.	
NO.	MATERIAL	FINISH . REMARKS	NO.	MATERIAL	FINISH . REMARKS
UNITS	mm	SCALE	7 : 1	COUNT	6
		DESCRIPTION OF REVISIONS	DESIGNED	CHECKED	DATE
		DIS-F-00001573	RT. IKEDA	HS. SAKAMOTO	16.09.06
APPROVED : NF. MIYAZAKI		15.12.26	DRAWING NO. EDC-357595-00-00		
CHECKED : SJ. OKAMURA		15.12.26	PART NO. FH63-**-S-0.5SH		
DESIGNED : SH. YAMAGUCHI		15.12.26	CODE NO. CL580		
DRAWN : SH. YAMAGUCHI		15.12.26	1/8		

Nov.1.2017 Copyright 2017 HIROSE ELECTRIC CO., LTD. All Rights Reserved.

**Recommended FPC**

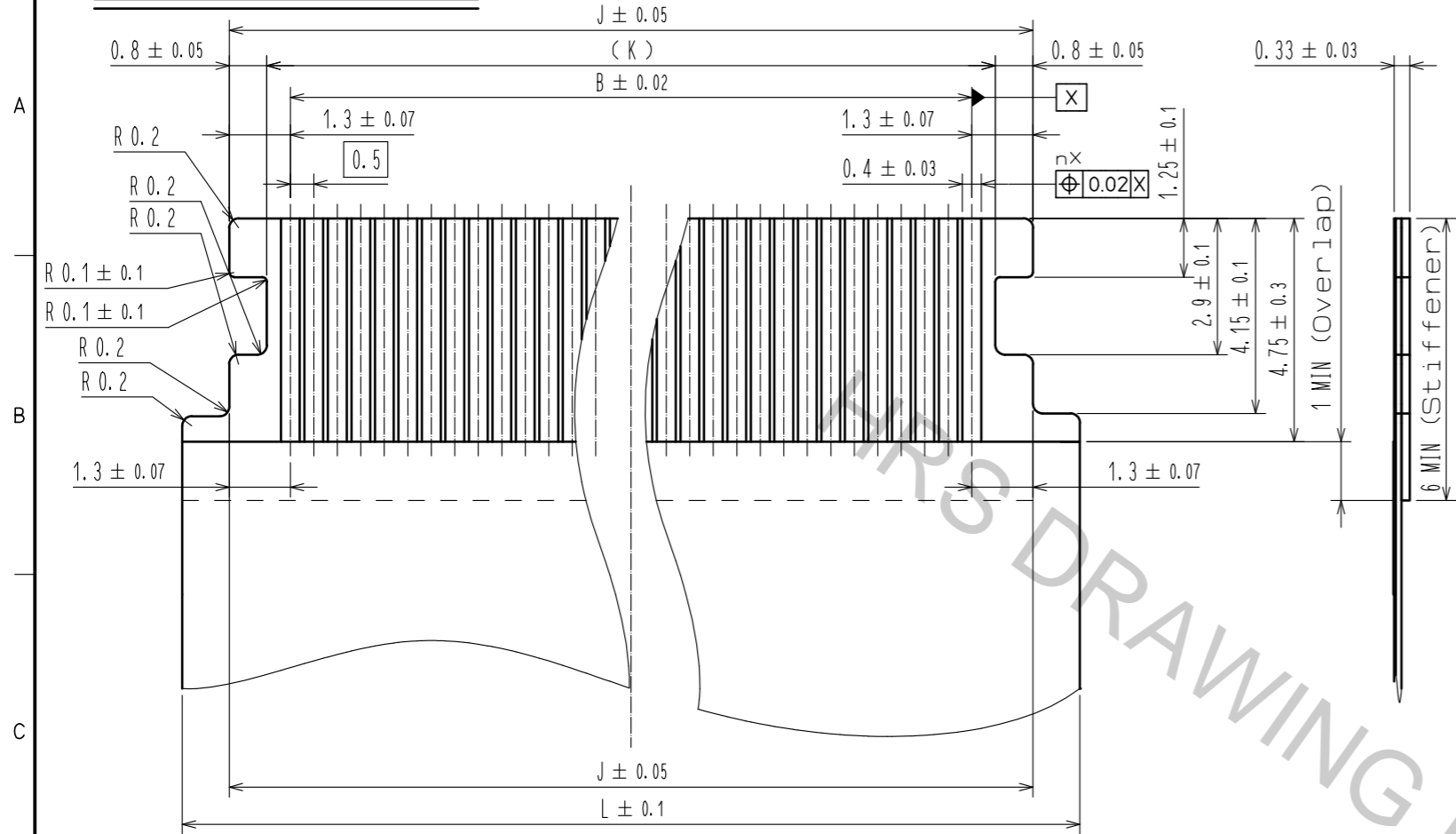

**Recommended FFC/shielded FFC**

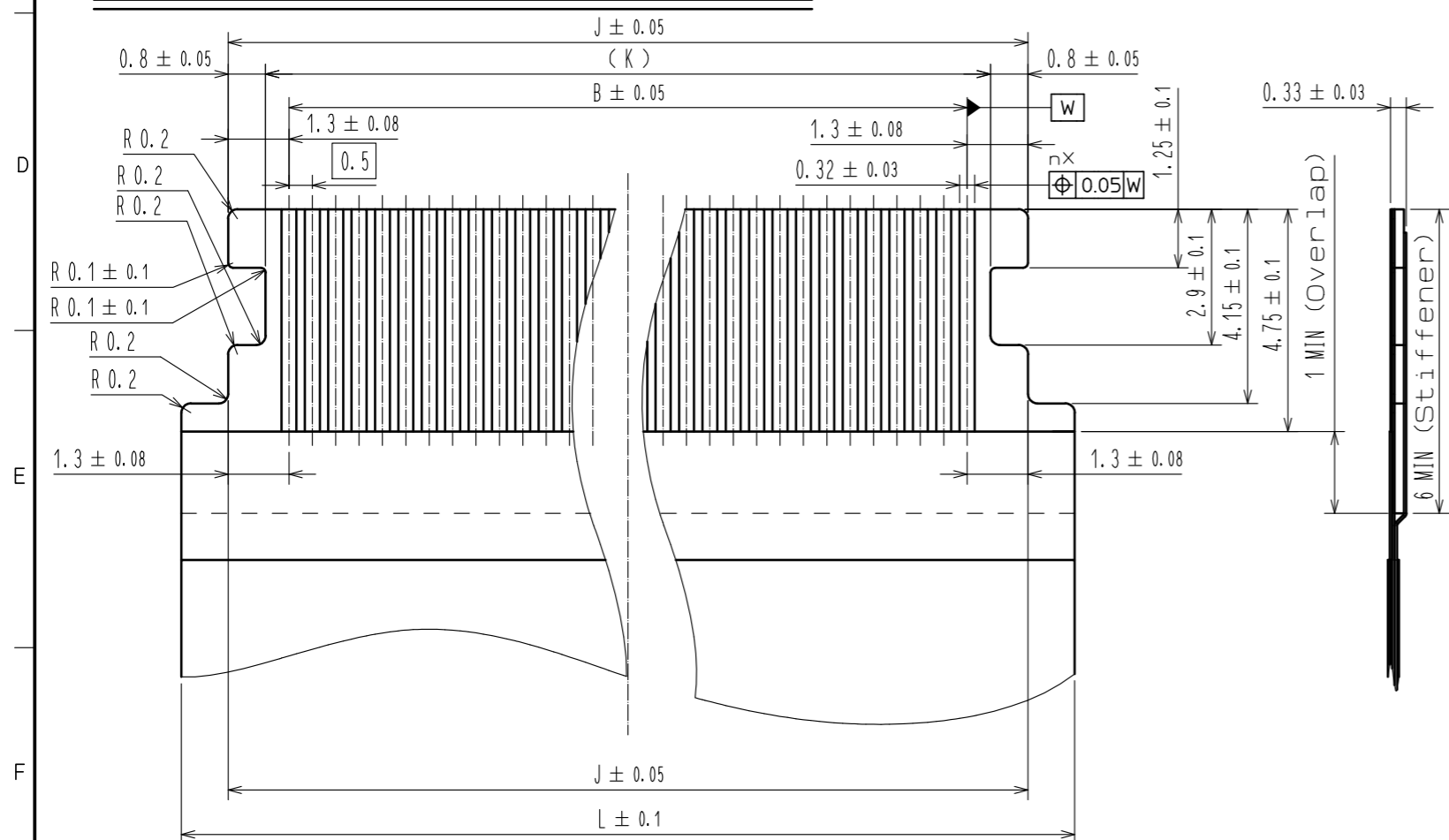

**FPC/FFC/shielded FFC configuration (Reference example)**

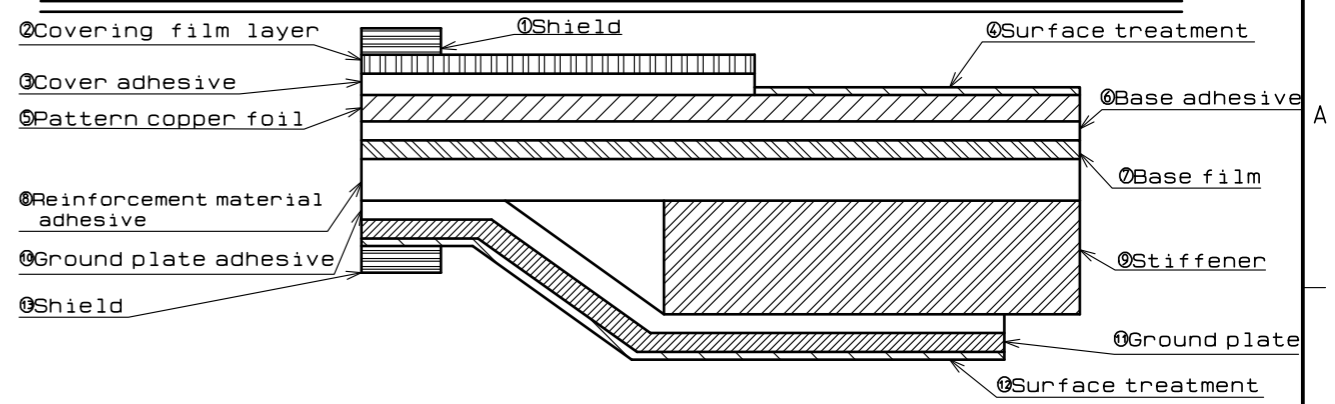

Material name	FPC		FFC	
	Material	Thickness (μm)	Material	Thickness (μm)
① Shield	—	—	—	—
② Covering film layer	Polyimide 1mil	25	Polyester type	25
③ Cover adhesive	Heat-hardened adhesive	28	Adhesive	25
④ Surface treatment	1μm to 6μm nickel underplated 0.2μm gold plated	(3.7)	0.5μm to 5μm nickel underplated 0.05μm to 0.5μm gold plated	(3.275)
⑤ Pattern copper foil	Cu 1 oz	35	Soft copper film	35
⑥ Base adhesive	Heat-hardened adhesive	8	Adhesive	25
⑦ Base film	Polyimide 1mil	25	Polyester type	50
⑧ Reinforcement material adhesive	Heat-hardened adhesive	55	Adhesive	30
⑨ Stiffener	Polyimide 8mil	200	Polyester type	150
⑩ Ground plate adhesive	—	—	Adhesive	30
⑪ Ground plate	—	—	Conductive tape	—
⑫ Surface treatment	—	—	Tin plating 1μm to 5μm	37
⑬ Shield	—	—	—	—

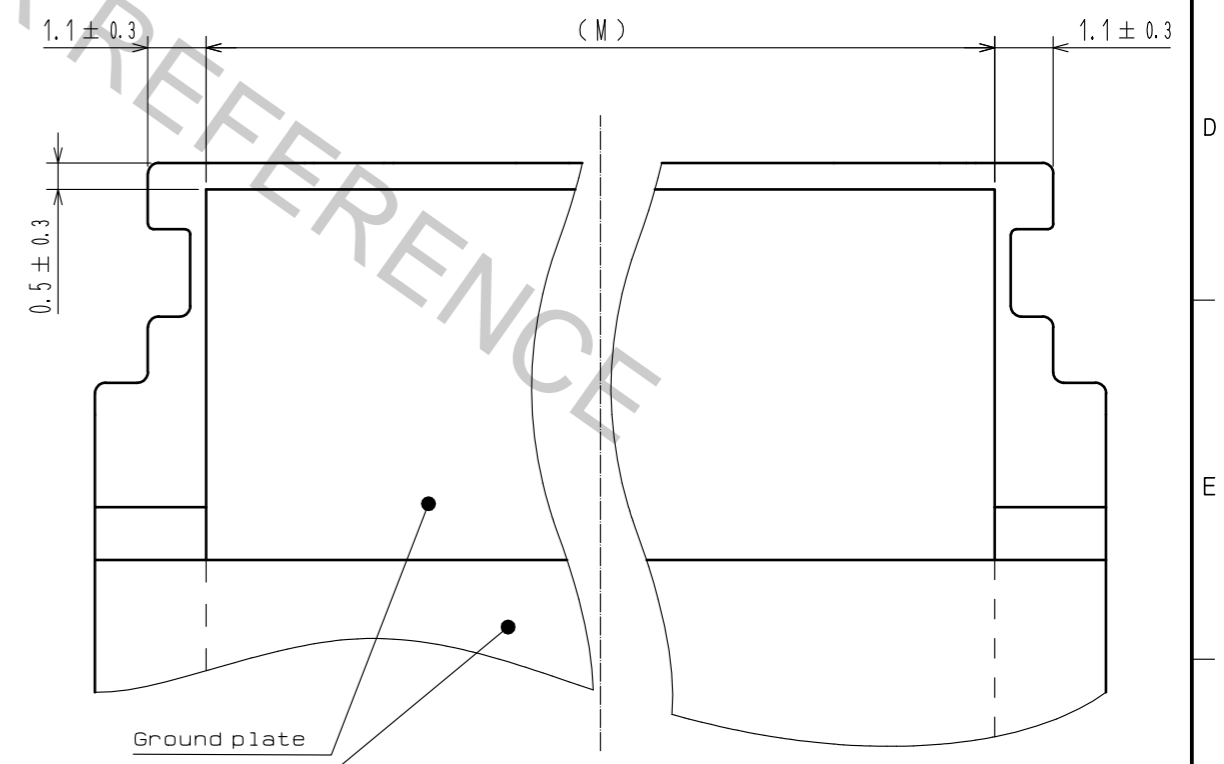

8 Please overlap shield area on ground plate .

**HRS** DRAWING NO. EDC-357595-00-00  
 PART NO. FH63-\*\*S-0.5SH  
 CODE NO. CL580

# Embossed carrier tape dimension (2:1)

# Reel dimension (No scale)

■ TAPE WIDTH: 24mm MAX

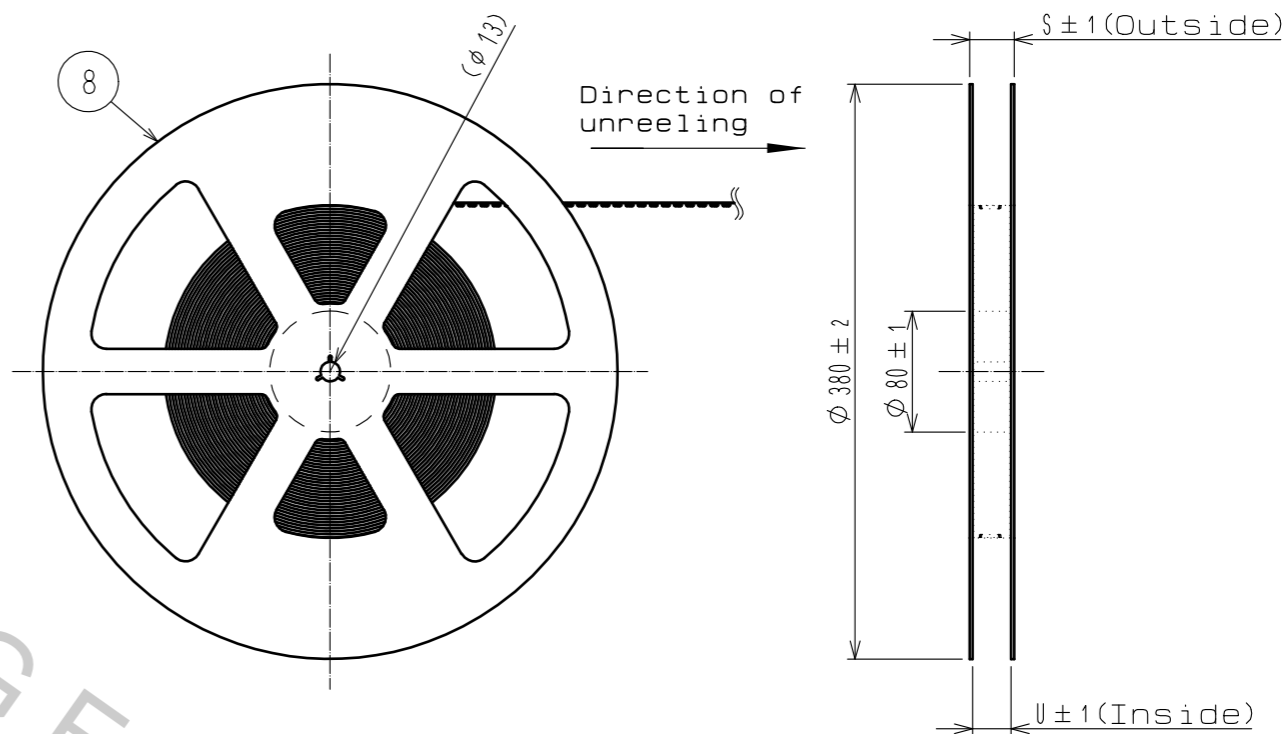
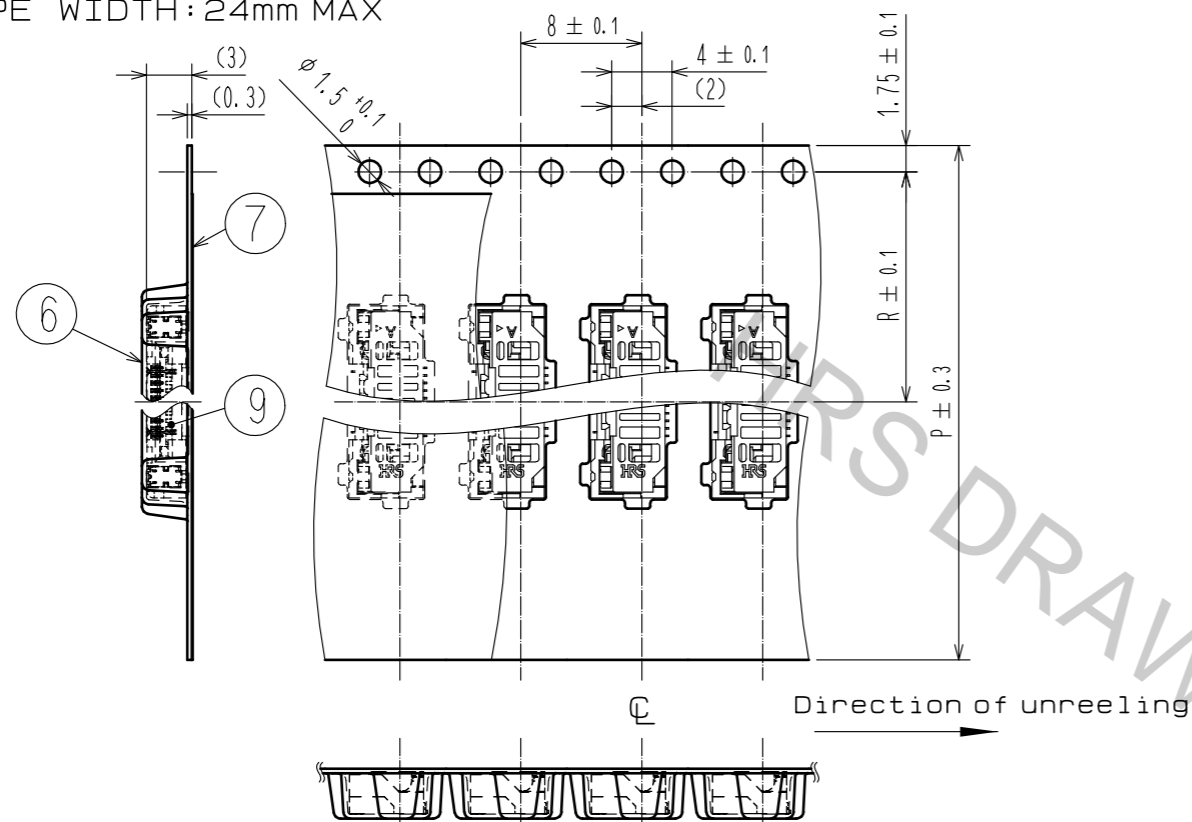

■ TAPE WIDTH: 32mm MIN

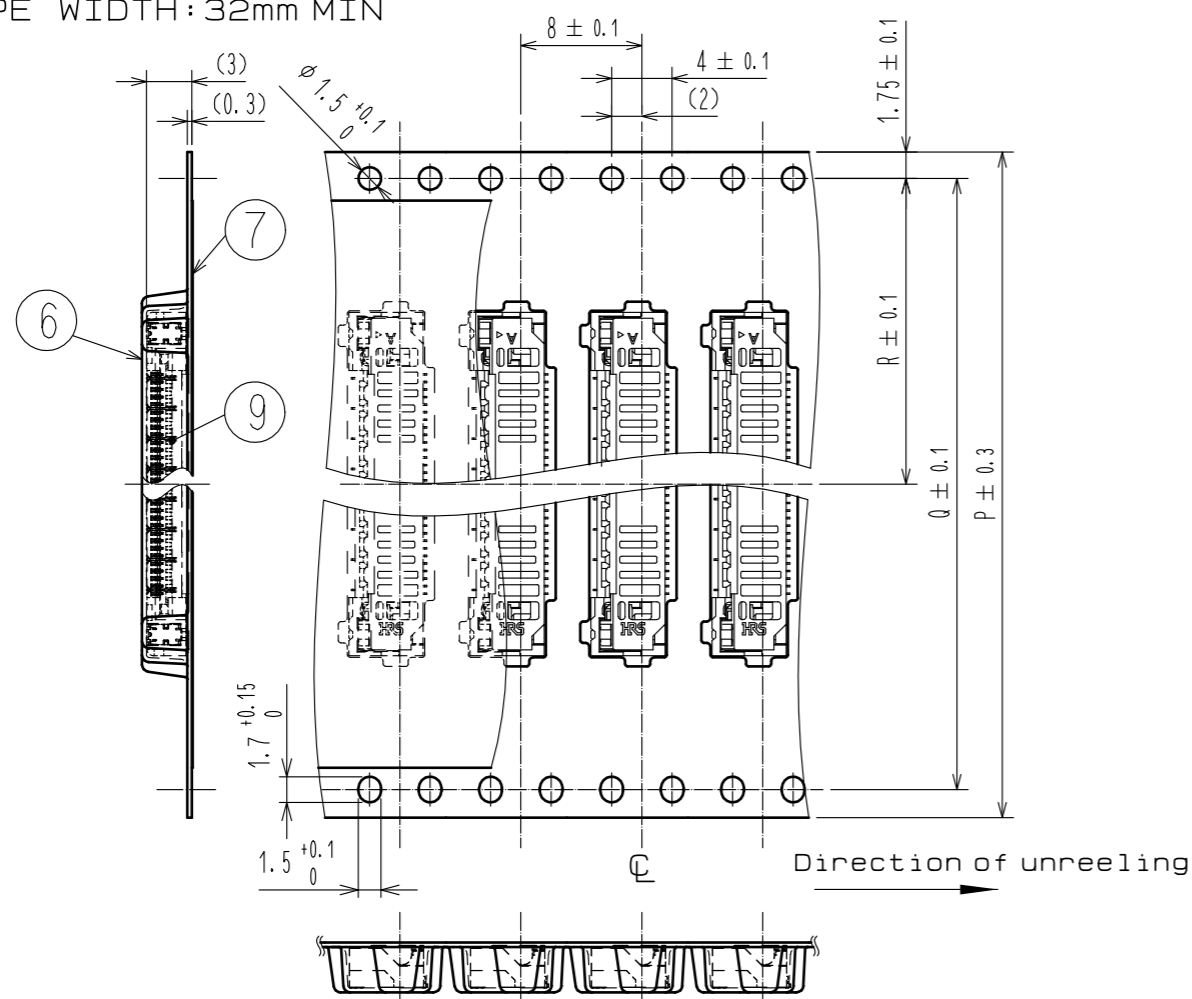

# Leader, Trailer dimension (No scale)

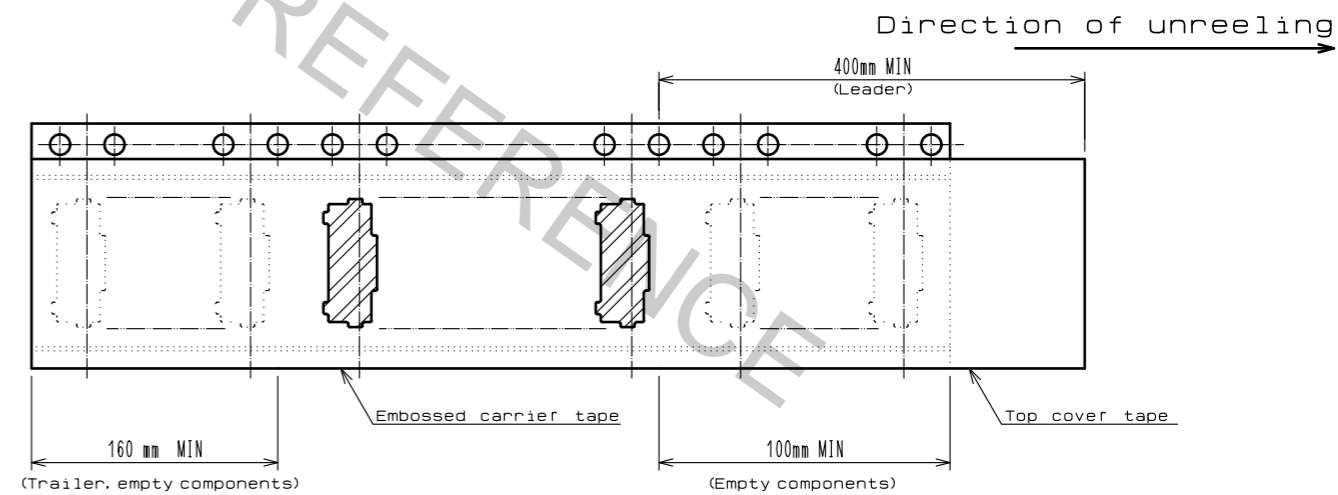

Notes 9 1 reel : 3500 connectors  
 10 Refer to JIS C 0806 and IEC 60286-3  
 (Packaging of components for automatic handling)

<Packing specification>

<b>HRS</b>	DRAWING NO.	EDC-357595-00-00
	PART NO.	FH63-***S-0.5SH
	CODE NO.	CL580
		$\frac{3}{8}$

Part No.	Code Number	Number of contacts	Dimension of connector, PCB mounting pattern, metal mask, FPC, FFC, and shielded FFC											Dimension of drawing for packing					
			A	B	C	D	E	F	G	H	J	K	L	M	P	Q	R	S	U
FH63-10S-0.5SH		10	12.7	4.5	5.55	4	2	7.15	9.9	3	7.1	5.5	9.1	4.9	24	-	11.5	29.4	25.4
FH63-12S-0.5SH		12	13.7	5.5	6.55	5	1.5	8.15	10.9	4	8.1	6.5	10.1	5.9	24	-	11.5	29.4	25.4
FH63-14S-0.5SH		14	14.7	6.5	5.55	6	2	9.15	11.9	4	9.1	7.5	11.1	6.9	32	28.4	14.2	37.4	33.4
FH63-16S-0.5SH		16	15.7	7.5	6.55	7	1.5	10.15	12.9	5	10.1	8.5	12.1	7.9	32	28.4	14.2	37.4	33.4
FH63-18S-0.5SH		18	16.7	8.5	5.55	8	2	11.15	13.9	5	11.1	9.5	13.1	8.9	32	28.4	14.2	37.4	33.4
FH63-20S-0.5SH		20	17.7	9.5	6.55	9	1.5	12.15	14.9	6	12.1	10.5	14.1	9.9	32	28.4	14.2	37.4	33.4
FH63-22S-0.5SH		22	18.7	10.5	5.55	10	2	13.15	15.9	6	13.1	11.5	15.1	10.9	44	40.4	20.2	49.4	45.4
FH63-24S-0.5SH		24	19.7	11.5	6.55	11	1.5	14.15	16.9	7	14.1	12.5	16.1	11.9	44	40.4	20.2	49.4	45.4
FH63-26S-0.5SH		26	20.7	12.5	5.55	12	2	15.15	17.9	7	15.1	13.5	17.1	12.9	44	40.4	20.2	49.4	45.4
FH63-28S-0.5SH		28	21.7	13.5	6.55	13	1.5	16.15	18.9	8	16.1	14.5	18.1	13.9	44	40.4	20.2	49.4	45.4
FH63-30S-0.5SH	CL580-4400-0-00	30	22.7	14.5	5.55	14	2	17.15	19.9	8	17.1	15.5	19.1	14.9	44	40.4	20.2	49.4	45.4
FH63-32S-0.5SH		32	23.7	15.5	6.55	15	1.5	18.15	20.9	9	18.1	16.5	20.1	15.9	44	40.4	20.2	49.4	45.4
FH63-34S-0.5SH		34	24.7	16.5	7.55	16	2	19.15	21.9	9	19.1	17.5	21.1	16.9	44	40.4	20.2	49.4	45.4
FH63-36S-0.5SH		36	25.7	17.5	8.55	17	1.5	20.15	22.9	10	20.1	18.5	22.1	17.9	44	40.4	20.2	49.4	45.4
FH63-38S-0.5SH		38	26.7	18.5	9.55	18	2	21.15	23.9	10	21.1	19.5	23.1	18.9	44	40.4	20.2	49.4	45.4
FH63-40S-0.5SH		40	27.7	19.5	10.55	19	1.5	22.15	24.9	11	22.1	20.5	24.1	19.9	44	40.4	20.2	49.4	45.4
FH63-42S-0.5SH		42	28.7	20.5	11.55	20	2	23.15	25.9	11	23.1	21.5	25.1	20.9	44	40.4	20.2	49.4	45.4
FH63-44S-0.5SH		44	29.7	21.5	12.55	21	1.5	24.15	26.9	12	24.1	22.5	26.1	21.9	44	40.4	20.2	49.4	45.4
FH63-46S-0.5SH		46	30.7	22.5	13.55	22	2	25.15	27.9	12	25.1	23.5	27.1	22.9	56	52.4	26.2	61.4	57.4
FH63-48S-0.5SH		48	31.7	23.5	14.55	23	1.5	26.15	28.9	13	26.1	24.5	28.1	23.9	56	52.4	26.2	61.4	57.4
FH63-50S-0.5SH		50	32.7	24.5	15.55	24	2	27.15	29.9	13	27.1	25.5	29.1	24.9	56	52.4	26.2	61.4	57.4
FH63-52S-0.5SH		52	33.7	25.5	16.55	25	1.5	28.15	30.9	14	28.1	26.5	30.1	25.9	56	52.4	26.2	61.4	57.4
FH63-54S-0.5SH		54	34.7	26.5	17.55	26	2	29.15	31.9	14	29.1	27.5	31.1	26.9	56	52.4	26.2	61.4	57.4
FH63-56S-0.5SH		56	35.7	27.5	18.55	27	1.5	30.15	32.9	15	30.1	28.5	32.1	27.9	56	52.4	26.2	61.4	57.4
FH63-58S-0.5SH		58	36.7	28.5	19.55	28	2	31.15	33.9	15	31.1	29.5	33.1	28.9	56	52.4	26.2	61.4	57.4
FH63-60S-0.5SH		60	37.7	29.5	20.55	29	1.5	32.15	34.9	16	32.1	30.5	34.1	29.9	56	52.4	26.2	61.4	57.4

※The products without code number are currently under planning.  
Please contact HIROSE for detailed information about product variation.

<Dimension table>

<b>HRS</b>	DRAWING NO.	EDC-357595-00-00
	PART NO.	FH63-***S-0.5SH
	CODE NO.	CL580
		4/8

Nov.1.2017 Copyright 2017 HIROSE ELECTRIC CO., LTD. All Rights Reserved.

This connector requires delicate and careful handling.  
 To prevent connector/FPC breakage and contact failure (mating failure, FPC pattern breakage, etc),  
 read through the instructions shown below and handle the connector properly.  
 This instruction manual is applicable to usage with FPC/FFC/shielded FFC.

[Connector part nomenclature]

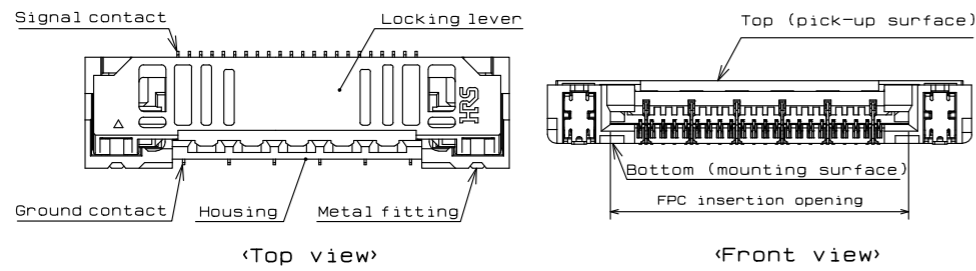

[Operation and precautions]

1. Initial condition

The product is supplied with the locking lever closed.  
 Locking lever does not have to be operated before inserting FPC.

[Caution]

- Do not open the locking lever when the FPC is not inserted.  
 The locking lever is to be used only when extracting the FPC (Example 1).
- Do not insert FPC or operate locking lever before mounting (Example 1).

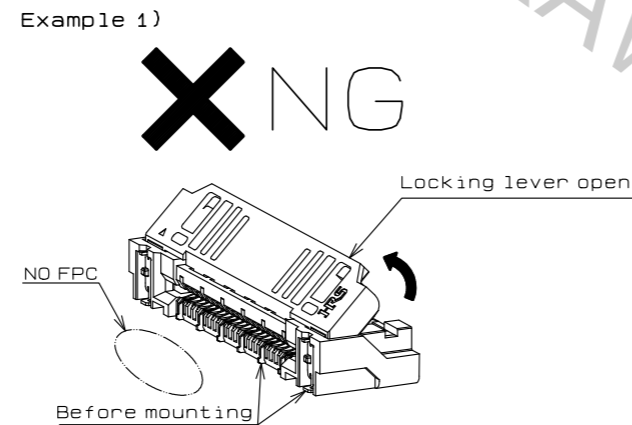

2. How to insert FPC

Insert the FPC into the connector opening horizontally to the PCB surface (Example 2).  
 Insert it properly to the very end.

[Caution]

- Make sure the locking lever is closed when inserting the FPC.  
 Do not insert the FPC when the locking lever is open (Example 3).
- Do not insert the FPC when the locking lever is pressed from above a finger. (Example 4).
- Align both sides of FPC horizontally to the sides of the connector opening and insert straight forward.
- Do not twist the FPC to up and down or right and left or an angle (Example 5, 6).

Example 2)

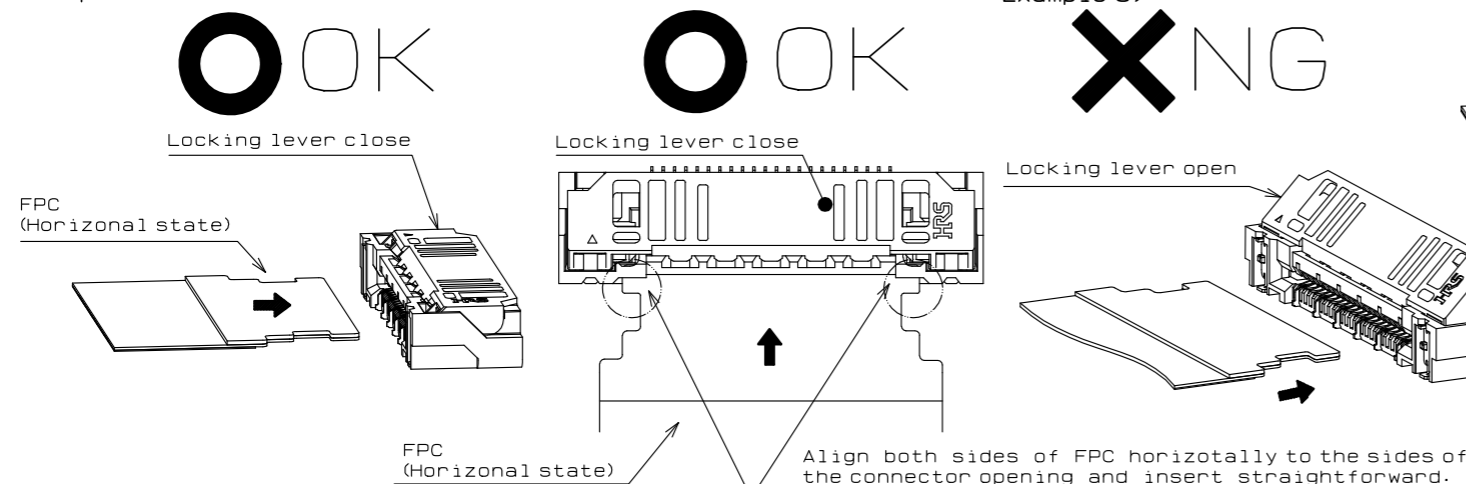

Example 3)

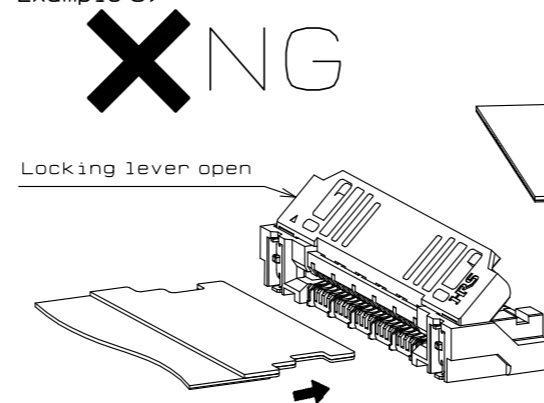

Example 4)

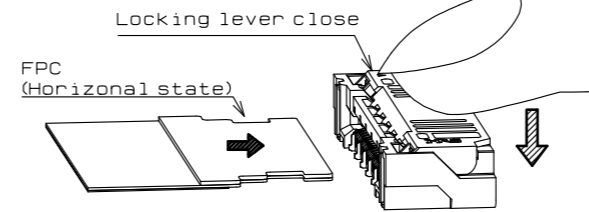

Example 5)

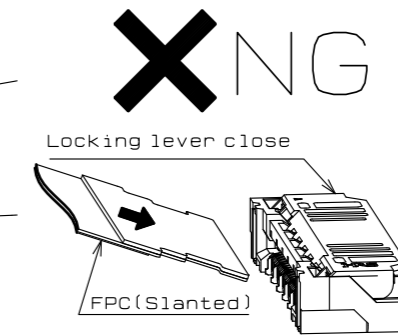

Example 6)

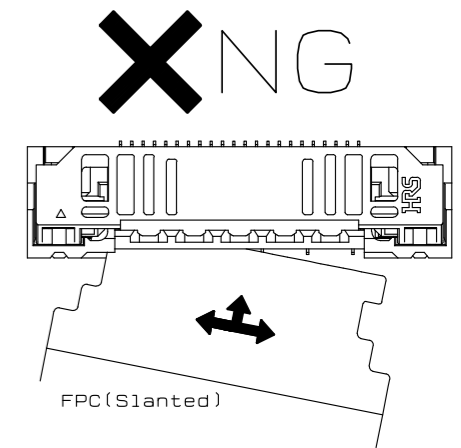

3. FPC insertion check

Make sure that the FPC tabs are located in proper position after FPC insertion (Example 7).  
 (The FPC position is to be aligned by the protrusion of the locking lever.)

[Caution]

- Do not insert the FPC at an angle and/or stop it before insertion is completed (Example 8, 9).
- As this product is designed for one action locking, the locking lever does not have to be operated after inserting FPC.

Example 7)

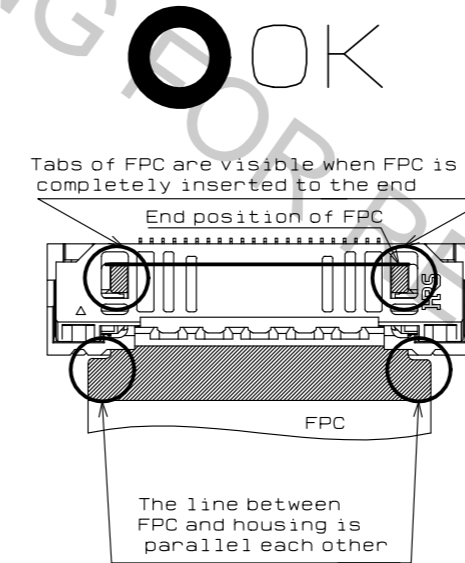

Example 8)

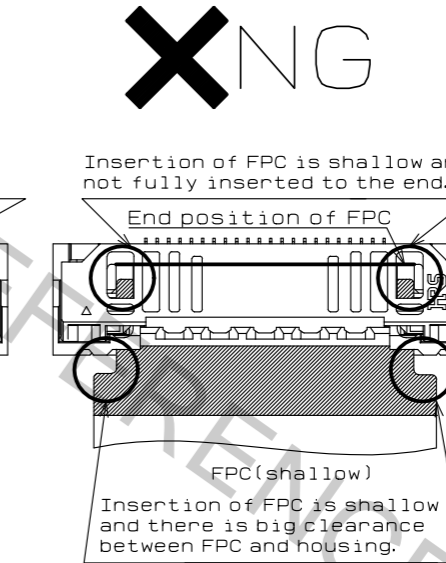

Example 9)

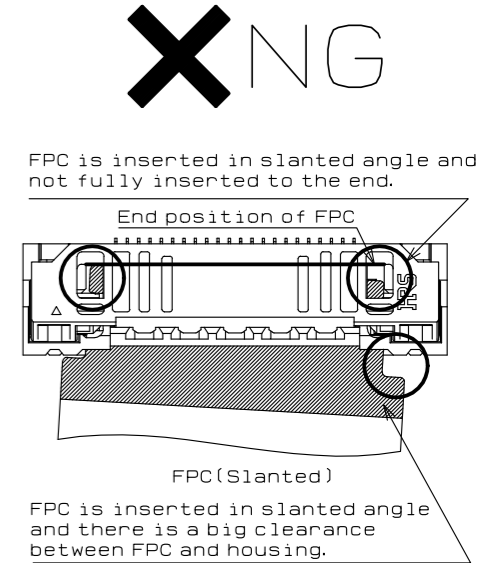

Section - locking area -

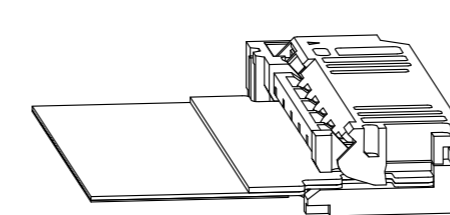

Section - locking area -

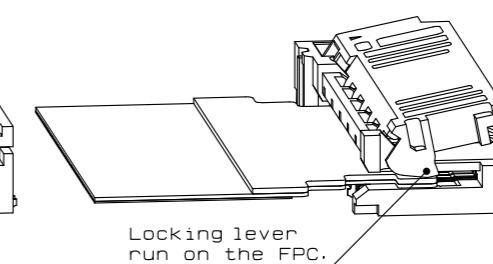

Section - locking area -

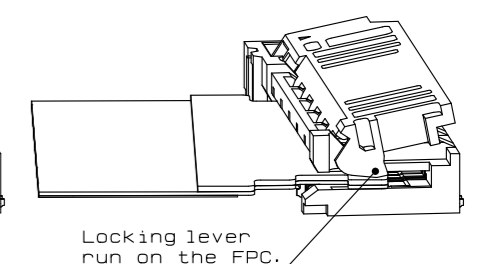

<Instruction manual(1)>

<b>HRS</b>	DRAWING NO.	EDC-357595-00-00
	PART NO.	FH63-**S-0.5SH
	CODE NO.	CL580
		5/8

4. How to release the lock  
 Slowly flip up the locking lever to release the lock (Example 10).

[Caution]

- To open the locking lever, operate at the center of the locking lever (Example 11).
- To open the locking lever, do not operate the locking lever at one end only (Example 12).
- The locking lever is opened up to the movable limit, 45 degree. Do not open the locking lever beyond the specified degree or apply excess force to the locking lever (Example 13).
- Do not pick the locking lever to lift and pull it (Example 14).
- Operate the locking lever by hand without using sharp tool such as Tweezers. (Example 15).
- Do not apply excess force to the housing during the operation (Example 16).
- Do not try to open the lock lever from the FPC insertion side, as the locking lever is designed with the opposite direction from the FPC insertion direction (Example 17).

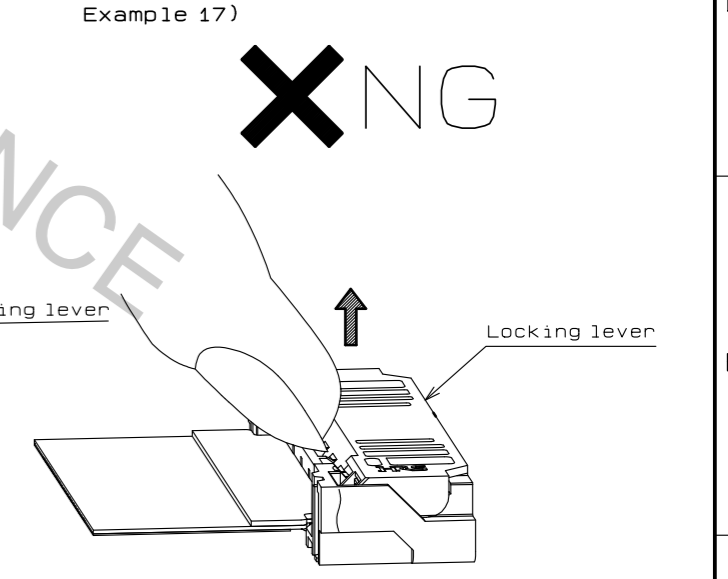
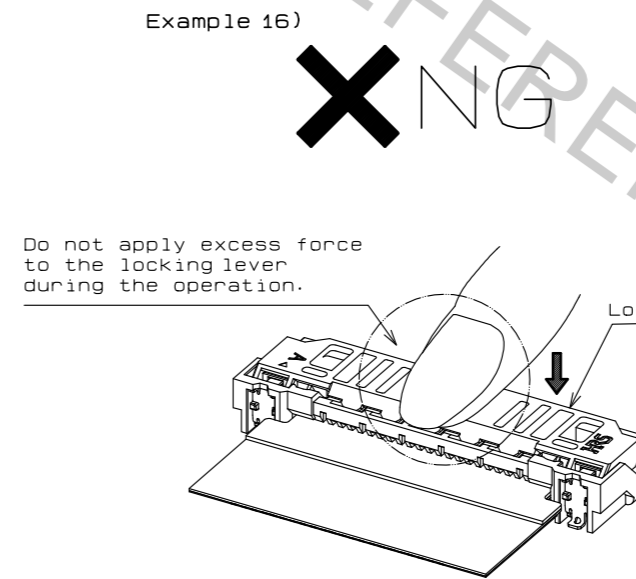
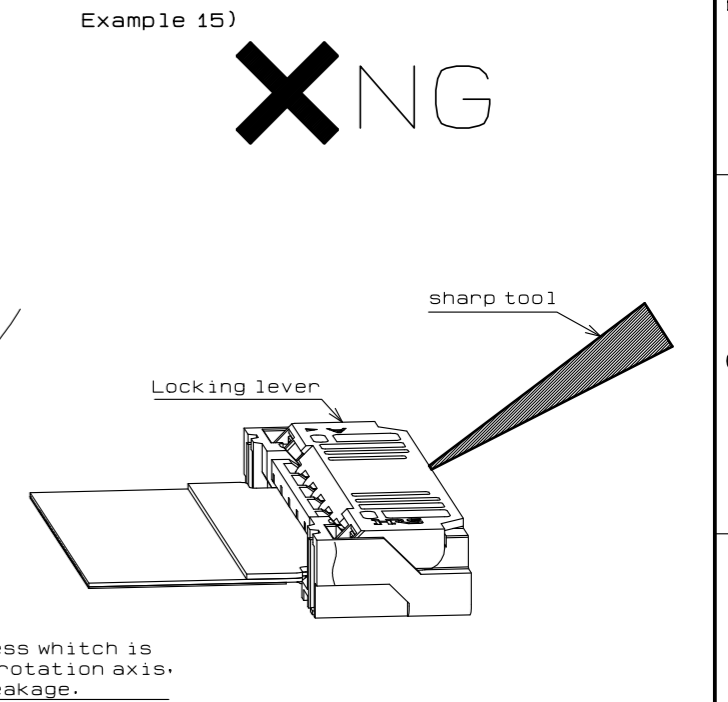
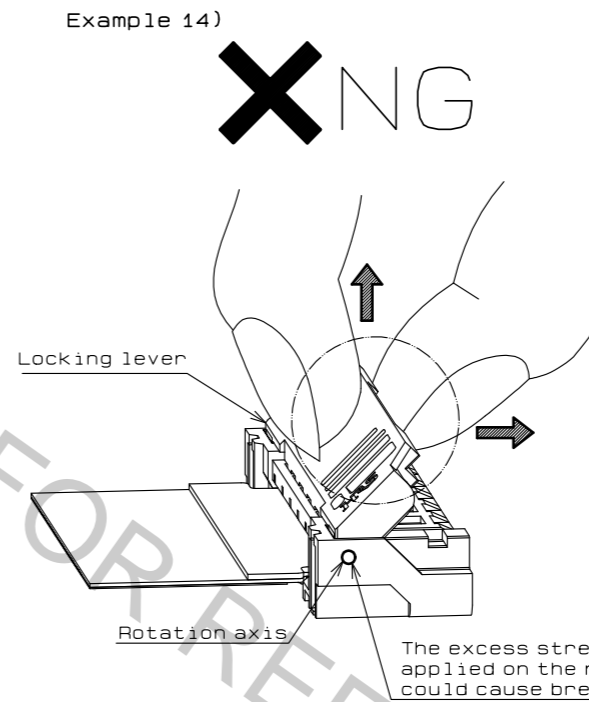
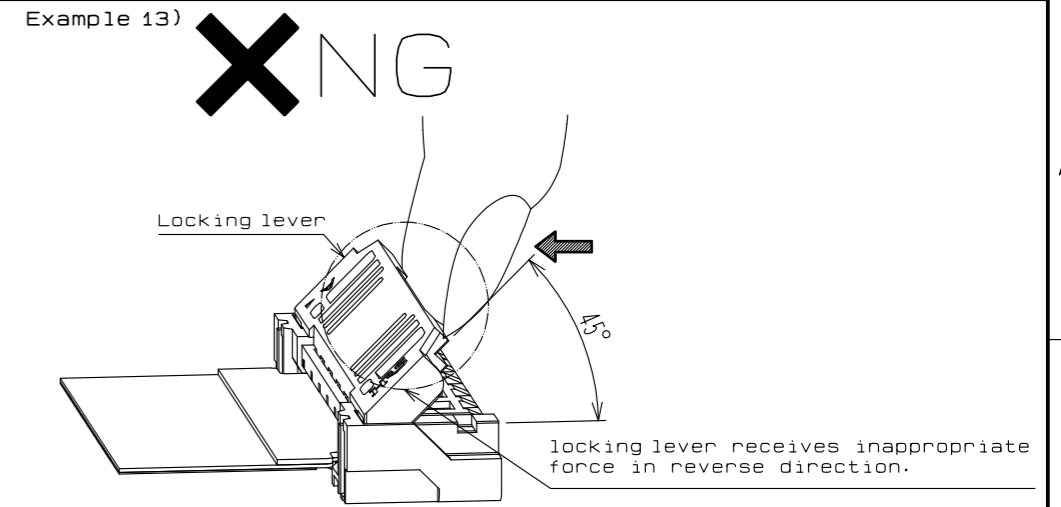
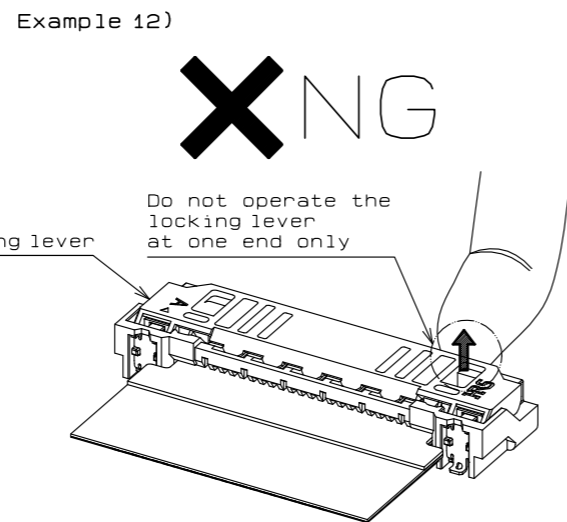
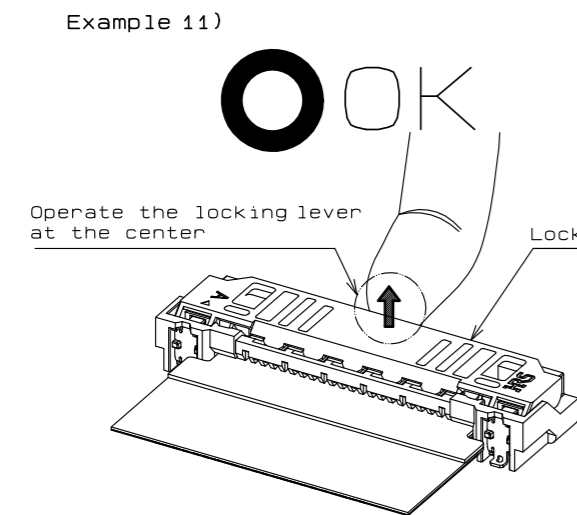
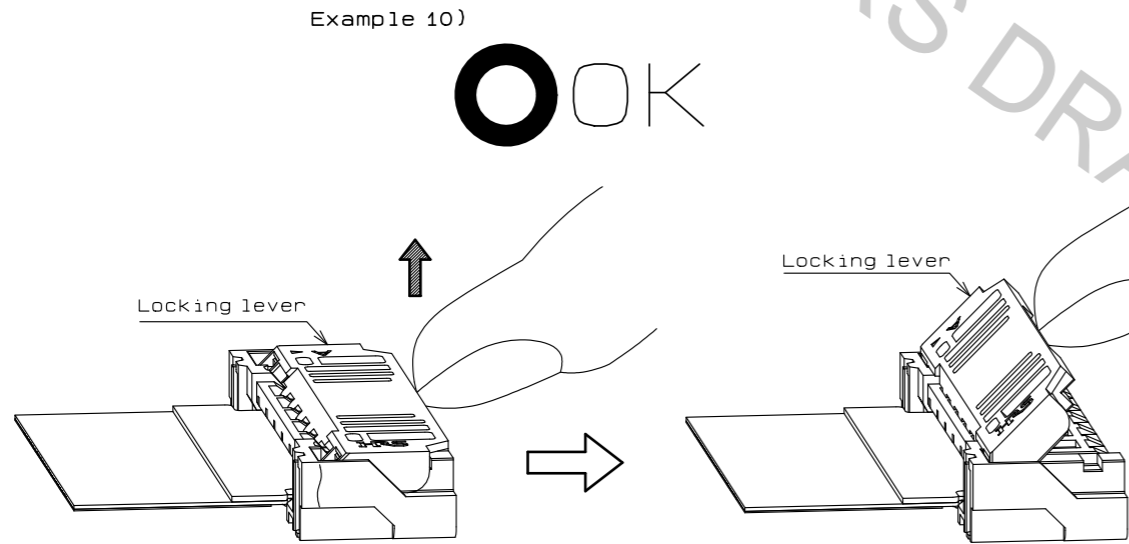

<Instruction manual(2)>

<b>HRS</b>	DRAWING NO.	EDC-357595-00-00
	PART NO.	FH63-**S-0.5SH
	CODE NO.	CL580

5. How to remove FPC

After flip up the locking lever to the fully opened position carefully withdraw the FPC (Example 18).  
Do not withdraw the FPC on the condition that the locking lever is held by a finger. (Example 19)  
As the locking lever can closed automatically while FPC is removed, locking lever does not have to be operated after removing FPC (Example 20).

[Caution]

- Do not attempt to pull the FPC without unlocking the locking lever (Example 21).
- This connector has a temporary FPC holding structure with the locking lever. For FPC removal, do not pull out the FPC upward or angled direction (Example 22).

[Precautions for component layout]

Depending on a FPC rounding, a load is applied to the connector, and a contact failure may occur.  
To prevent a failure, take the following notes into a consideration during mechanism design.

[Caution]

- When fixing FPC after FPC cabling, avoid pulling FPC, and route the wire FPC with slack. In this regard, the stiffener is parallel to the PCB (Example 23).
- Avoid applying forces to FPC in vertical or horizontal directions. Do not bend the FPC excessively near the connector during use, or it may cause contact failure or FPC breakage. Stabilizing the FPC is recommended (Example 24, 25).
- Do not mount other components touching to the FPC underneath the FPC stiffener (Example 26).
- Make adjustments with the FPC manufacturer for FPC bending performance and wire breakage.
- Keep a sufficient FPC insertion space in the stage of the layout in order to avoid incorrect FPC insertion. Appropriate FPC length and component layout are recommended for assembly ease. Too short FPC length makes assembly difficult.
- Keep spaces for the locking lever movement and its operation for PCB design and component layout.

Example 18)

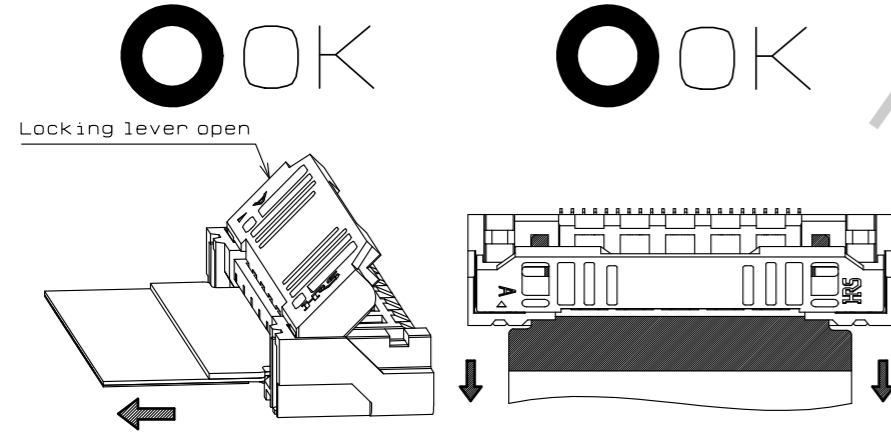

Example 19)

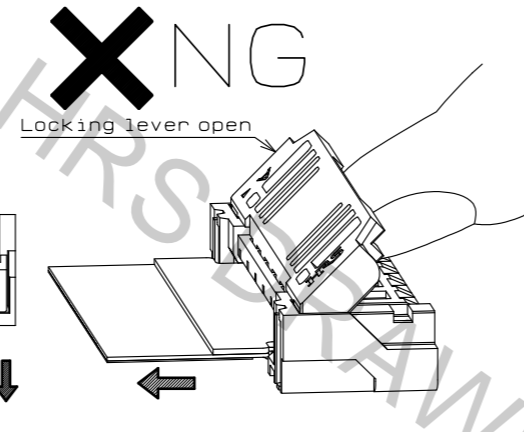

Example 20)

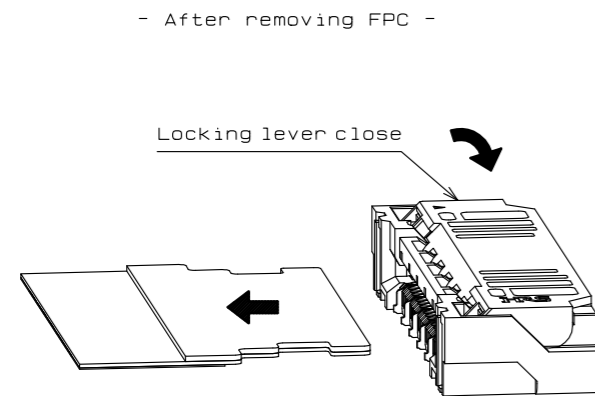

Example 21)

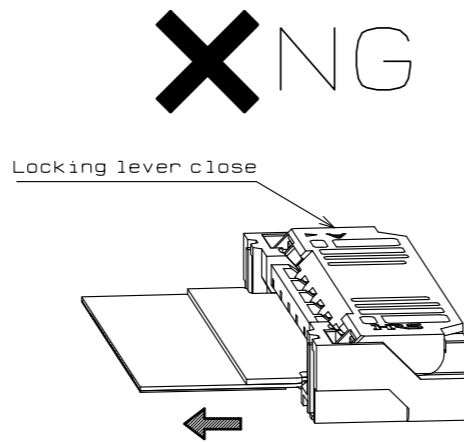

Example 22)

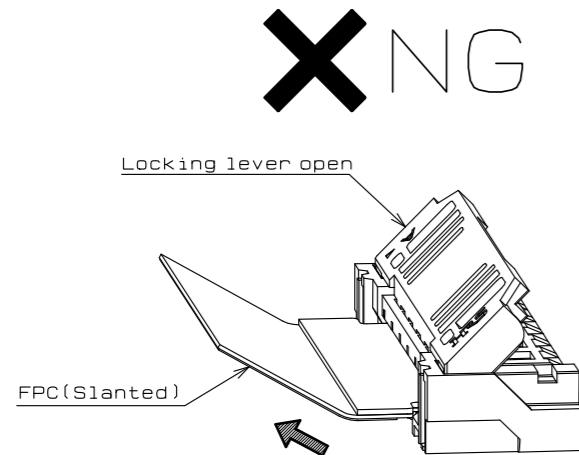

Example 21)

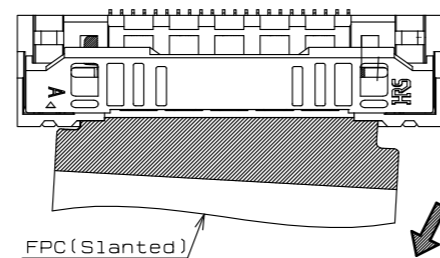

Example 23)

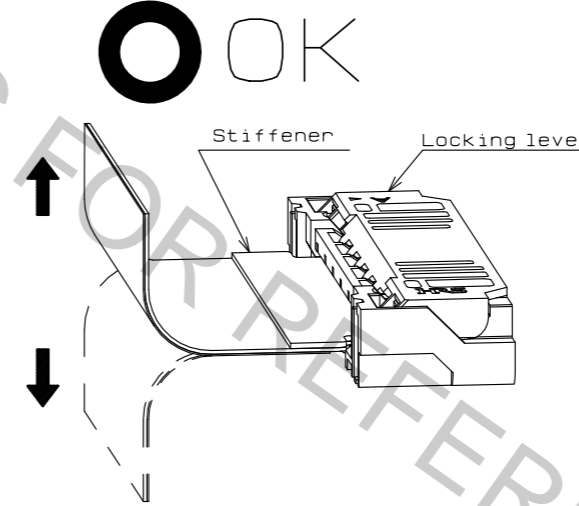

Example 24)

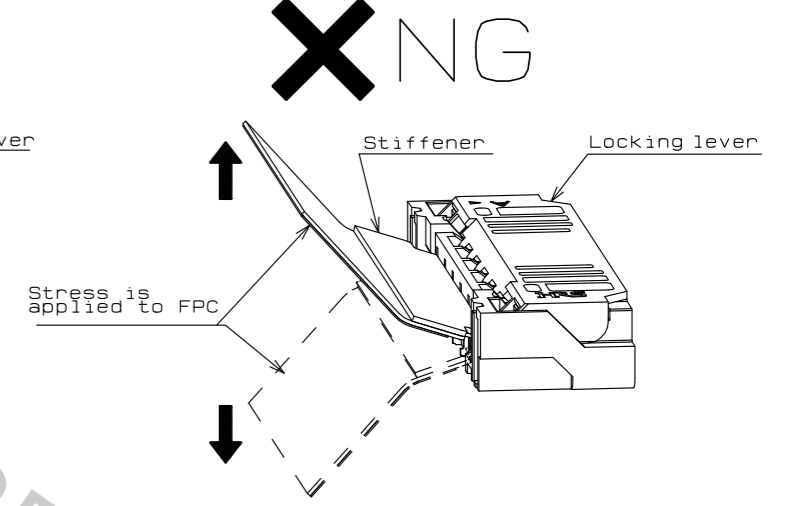

Example 25)

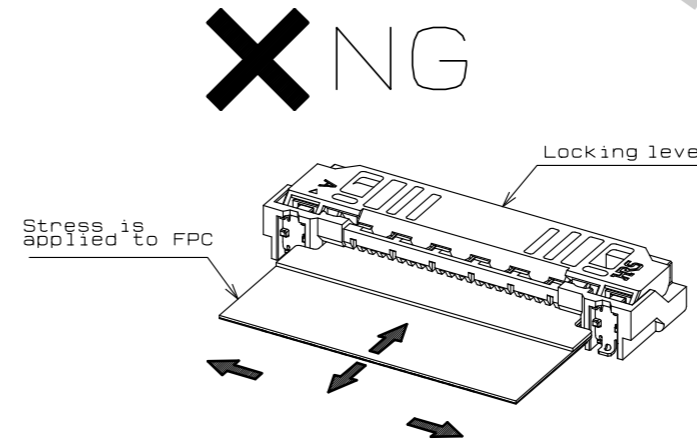

Example 26)

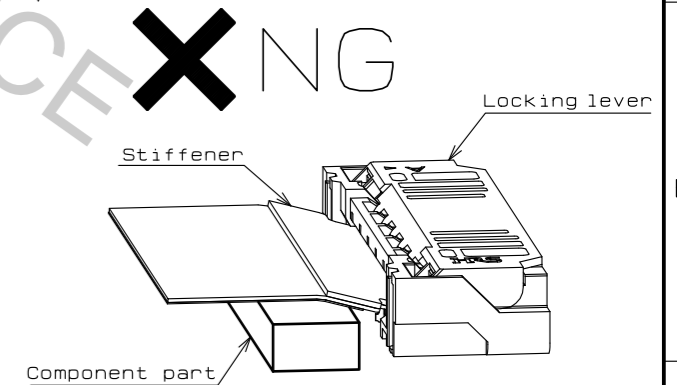

<Instruction manual(3)>

<b>HRS</b>	DRAWING NO.	EDC-357595-00-00
	PART NO.	FH63-**S-0.5SH
	CODE NO.	CL580
		7/8

[Instructions for mounting on the PCB]

Follow the instructions shown below when mounting on the PCB.

[Caution]

- Refer to recommended layouts on the page 1 for PCB and stencil pattern.
- Shorter pattern width than the recommended PCB dimension. could cause solder wicking and/or flux penetration.
- Larger pattern than the recommended stencil dimension. could cause solder wicking and/or flux penetration.
- Clearance underneath the contact lead and the housing is very small. In case solder resist and/or silk screening are applied on PCB underneath the connector, verify the thickness, or it could push up the connector bottom and may cause soldering defect and/or insufficient fillet formation.
- Apply reflow temperature profile within the specified conditions. In individual applications, the actual temperature may vary, depending on solder paste type, volume/thickness and PCB size/thickness. Consult your solder paste and equipment manufacturer for specific recommendations.
- Prevent warpage of PCB, where possible, since it can cause soldering failure :even with 0.1 mm max coplanarity.
- When mounting on the flexible board, please make sure to put a stiffener on the backside of the flexible board. We recommend a glass epoxy material with the thickness of 0.3 mm min.
- Do not add 1.0 N or greater external force when unreel or pick and place the connector etc. or it may get broken.

[Instructions for PCB handling after mounting the connector]

Follow the instructions shown below when mounting on the PCB.

[Caution]

- Splitting a large PCB into several pieces
  - Screwing the PCB
- During the handling described above, do not exert an excessive force on the PCB. Otherwise, the connector may become defective.
- The warp of a 100 mm wide PCB should be 1.0 mm or less.
- The warp of PCB suffers stress on connector and the connector may become defective (Example 27).

Example 27)

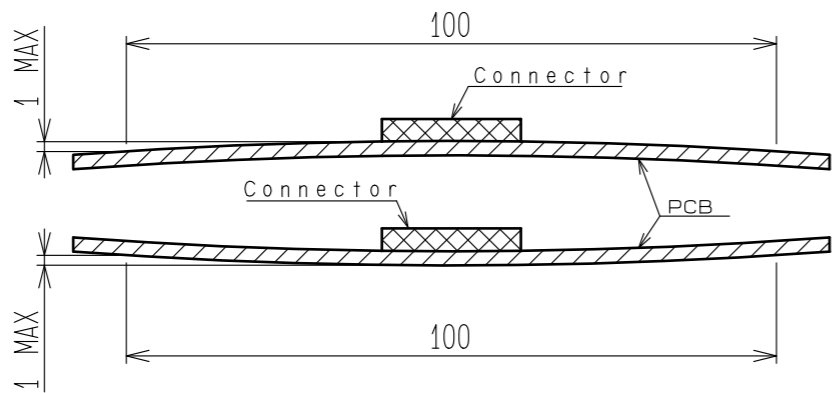

[Instructions on manual soldering]

Follow the instructions shown below when soldering the connector manually during repair work, etc.

[Caution]

- Do not perform manual soldering with the FPC inserted into the connector.
  - Do not heat the connector excessively. Be very careful not to let the soldering iron contact any parts other than connector leads. Otherwise, the connector may be deformed or melt.
  - Do not supply excessive solder (or flux).
- If excessive solder (or flux) is supplied on the terminals, solder or flux may adhere to the contacts, resulting in poor contact. Supplying excessive solder to the metal fittings may hinder locking lever rotation, resulting in breakage of the connector.

<Instruction manual(4)>

<b>HRS</b>	DRAWING NO.	EDC-357595-00-00
	PART NO.	FH63-***S-0.5SH
	CODE NO.	CL580