

DESCRIPTION: HD - 15 POS - MALE OVER MALE -0.750" CENTERS

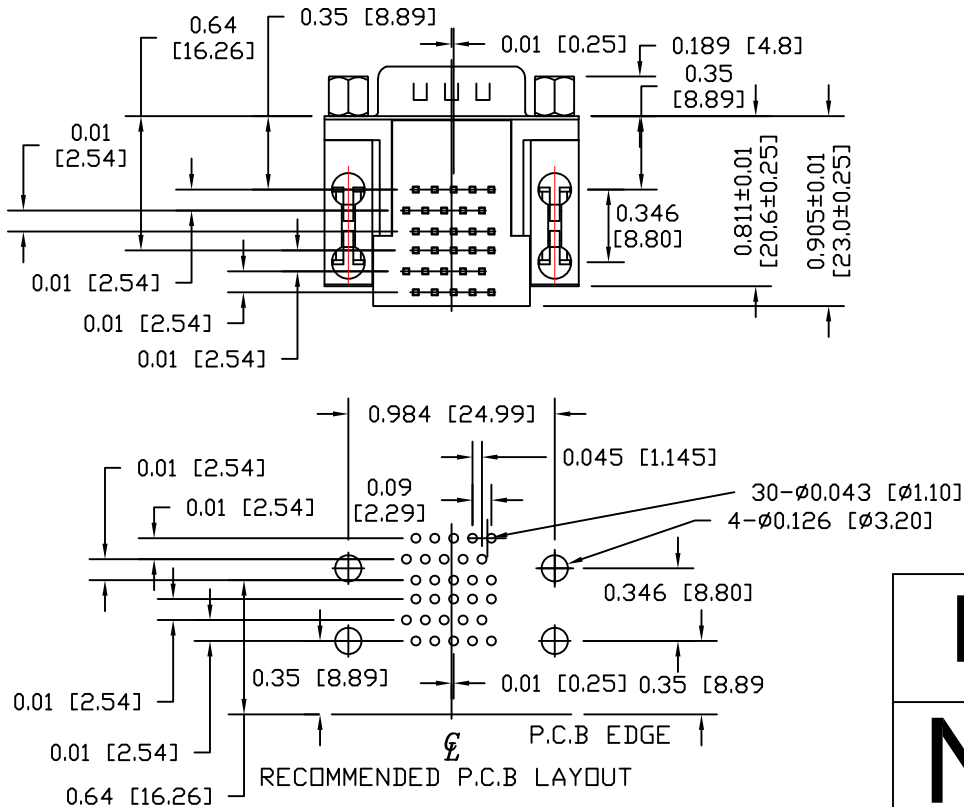
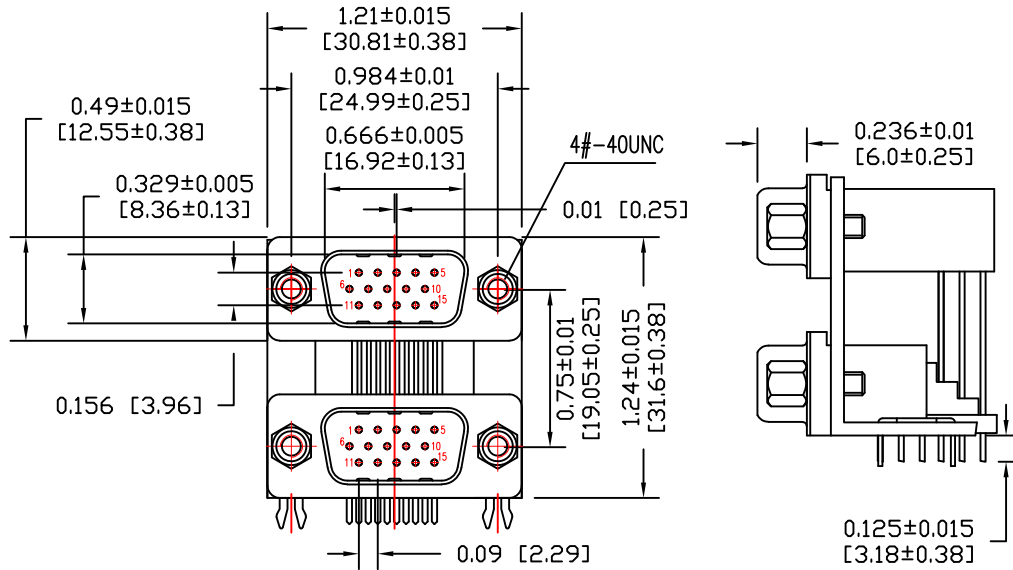

ELECTRICAL CHARACTERISTICS

VOLTAGE: 250 VAC (rms) Max.
 CURRENT RATING: 3 AMPS PER CONTACT
 CONTACT RESISTANCE: 25 Milliohms Max.
 INSULATION RESISTANCE: 5000 MOhms Min.
 DIELECTRIC WITHSTANDING: 1000 VAC (rms)
 TOTAL MATING FORCE: 6.0 Kgf Max.
 TOTAL UNMATING FORCE: 1.2 Kgf Min.
 OPERATING TEMPERATURE: -55°C TO +85°C

MATERIAL CHARACTERISTICS

HOUSING: PA9T, UL94V-0, BLACK
 CONTACTS: COPPER ALLOY
 SHELL: SPCC
 BOARDLOCK: COPPER ALLOY
 BRACKET: ZINC ALLOY
 SCREWLOCK: COPPER ALLOY

PLATING CHARACTERISTICS

CONTACTS: GOLD FLASH OVER NICKEL AT CONTACT AREA
 TIN PLATED OVER NICKEL AT THE SOLDER AREA
 SHELL: NICKEL PLATED
 BOARDLOCK: TIN PLATED
 BRACKET: NICKEL PLATED
 SCREWLOCK: NICKEL PLATED

178-YYY-613R577

SERIES _____
 POSITIONS _____
 H15 _____
 GENDER _____
 51 = MALE OVER MALE
 SHELL PLATING _____
 3 = NICKEL
 RoHS COMPLIANT (HIGH TEMP. PROCESS) _____
 HARDWARE OPTIONS _____
 57 = 4-40 STAND OFFS/BOARD LOCKS
 PLATING OPTIONS _____
 7 = GOLD FLASH MATING AREA WITH TIN TAILS

RoHS Compliant

	THESE DRAWINGS AND SPECIFICATIONS ARE THE PROPERTY OF NorComp AND SHALL NOT BE REPRODUCED, COPIED OR USED AS THE BASIS FOR THE MANUFACTURE OR SALE OF APPARATUS WITHOUT WRITTEN PERMISSION.		DRAWN: B. BRIDGES	DATE: 12/15/2017		
	NorComp			CHECKED:	DATE:	
SCALE: NTS				SHEET 1	OF 1	REV 0
DWG NO. 178-H15-613R577						