

THIS DRAWING IS UNPUBLISHED. RELEASED FOR PUBLICATION. ALL RIGHTS RESERVED.

REVISIONS				
P	LTR	DESCRIPTION	DATE	APVD
2		REVISED TOLERANCE	20APR2018	JS AS

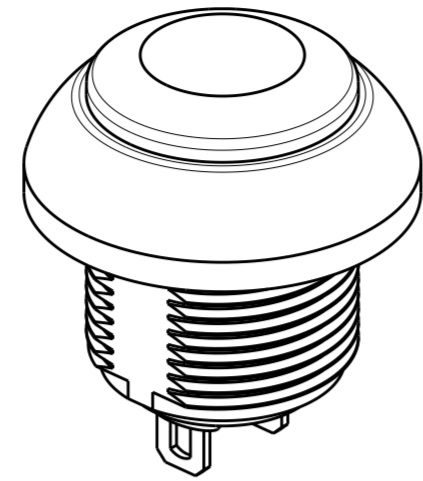
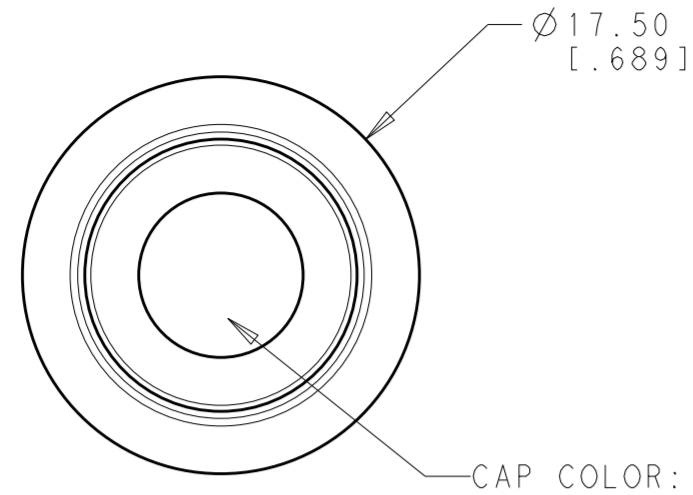

SOLDER TO WIRE  
OFF-(ON)

Model No.	POS. 1	POS. 2
PB6	OFF	MOM(ON)
CONNECTED TERMINALS	OPEN	CLOSE
SCHEMATIC		

SWITCH FUNCTION

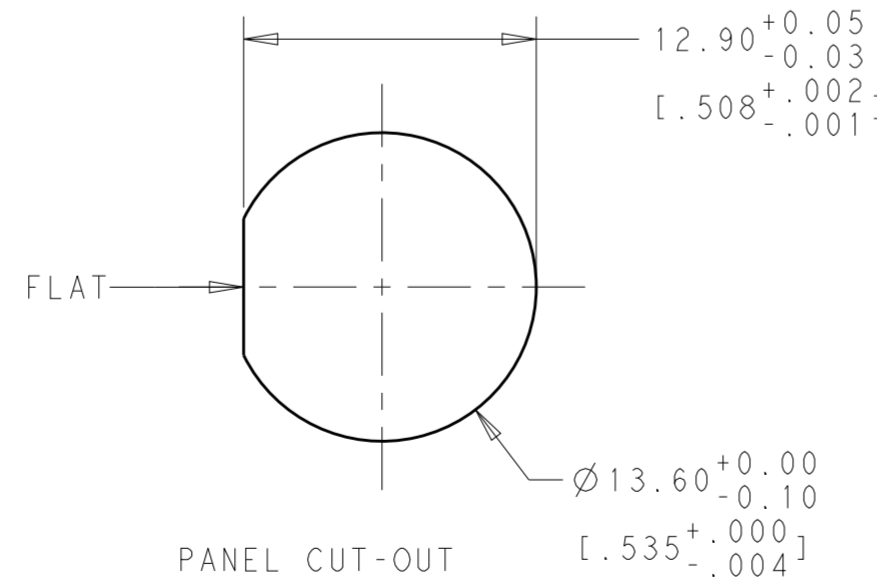
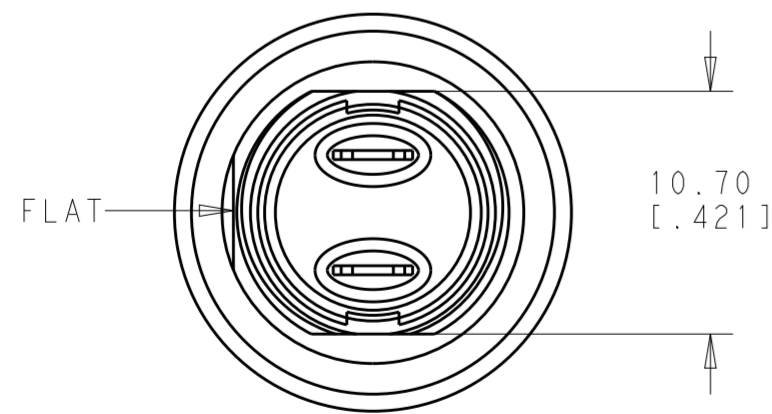
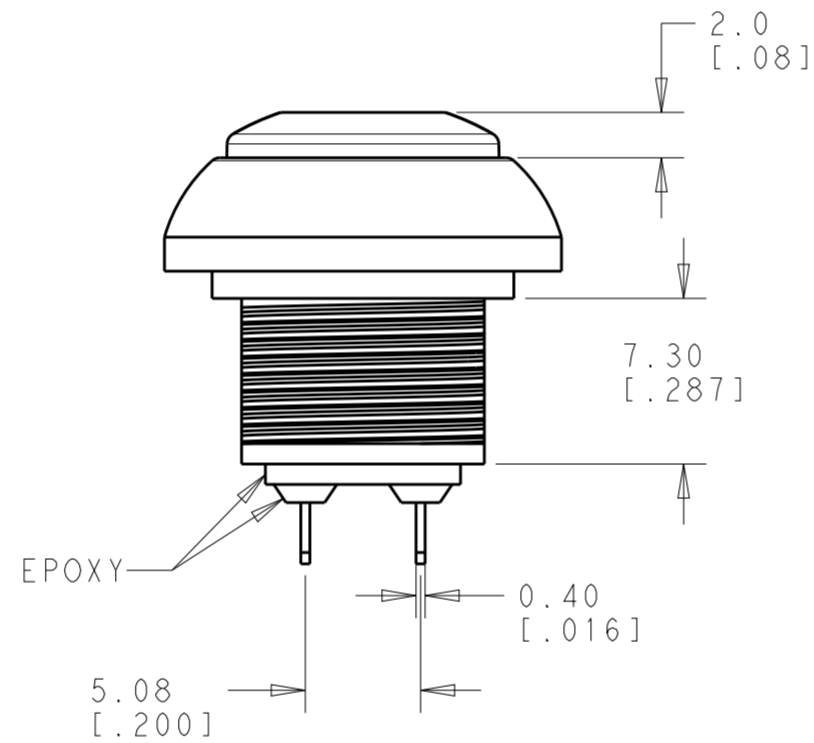
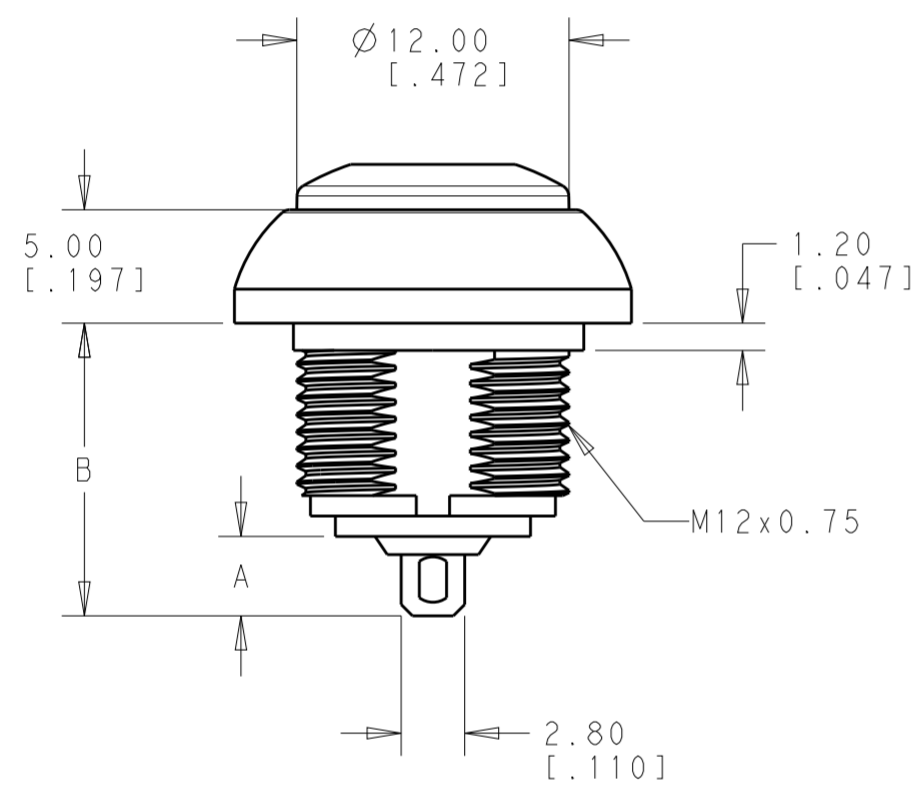

PANEL CUT-OUT  
THICKNESS: 1.5mm~4.0mm  
[0.059~.157]

**SPECIFICATIONS:**

MAXIMUM CURRENT/VOLTAGE RATING WITH RESISTIVE LOAD:  
400mA 32VAC, 200mA 50VDC, 125mA 125VAC

INITIAL CONTACT RESISTANCE: 50mΩ MAXIMUM  
 INSULATION RESISTANCE: 1 GΩ MINIMUM AT 500 VDC  
 DIELECTRIC STRENGTH: 1,500 VAC RMS  
 CONTACT BOUNCE: 10ms  
 ELECTRICAL LIFE AT FULL LOAD: 500,000 CYCLES  
 MECHANICAL LIFE: 1,000,000 CYCLES  
 TOTAL TRAVEL: 1.5 (.059)  
 ACTUATION FORCE: 3 TO 6N  
 OPERATING TEMPERATURE: -30° TO 85° C  
 DEGREE OF PROTECTION: IP68, 1 HOUR @ 1 METER  
 TORQUE: 0.5N·m MAXIMUM APPLIED TO NUT

**MATERIALS:**

CAP: POLYAMIDE 6/6  
 PLUNGER: POLYAMIDE 6/6 OR POLYCARBONATE  
 RUBBER: SILICONE  
 BUSHING: POLYAMIDE 6/6  
 CASE: DIALLYL PHTHALATE (DAP) (UL94 V-0)  
 TERMINALS/CONTACTS: COPPER ALLOY, GOLD OVER SILVER PLATED  
 HEX NUT: BRASS, NICKEL PLATED (1)  
 LOCK WASHER: BRASS, NICKEL PLATED (1)  
 O-RING: SILICONE (1)  
 SPRING: STEEL

**PACKAGING:**

SWITCHES ARE PACKAGED IN TRAYS. HARDWARE IS NOT ASSEMBLED TO THE SWITCH.

**COMPLIANCE:**

ALL MATERIALS AND FINISHES SHALL COMPLY WITH EU DIRECTIVE 2002/95/EC OF 27JAN2003(RoHS)

**SOLDER PROCESSING:**

MANUAL SOLDERING: SOLDER IRON, 30 WATTS, CONTROLLED AT 350° C, APPROXIMATELY 5 SECONDS WHILE APPLYING SOLDER.

**WAVE SOLDERING:**

260+/-5° C, 5 SECONDS MAXIMUM DURATION, PCB THICKNESS 1.6MM  
110°C MAXIMUM AMBIENT TEMPERATURE OF THE SOLDER SURFACE OF THE PC BOARD.

1. HARDWARE IS SHIPPED UNASSEMBLED.

THIS DRAWING IS A CONTROLLED DOCUMENT.		DWN RAVLS 22FEB2018	 TE Connectivity <b>PRELIMINARY</b>		
DIMENSIONS: mm[INCHES]		CHK ALEXANDER SHARPE 22FEB2018			NAME ALEXANDER SHARPE 22FEB2018
TOLERANCES UNLESS OTHERWISE SPECIFIED:		APVD ALEXANDER SHARPE 22FEB2018			PRODUCT SPEC
0 PLC ± 1 PLC ±0.4[0.016] 2 PLC ±0.25[0.010] 3 PLC ± 4 PLC ± ANGLES ±5° FINISH -		APPLICATION SPEC			RESTRICTED TO
MATERIAL		WEIGHT	SIZE A200779	CAGE CODE C-2329383	
CUSTOMER DRAWING		SCALE 4:1	SHEET 1 OF 4	REV 2	

THIS DRAWING IS UNPUBLISHED. RELEASED FOR PUBLICATION  
 © COPYRIGHT copyright.d8te- ALL RIGHTS RESERVED.

REVISIONS				
P	LTR	DESCRIPTION	DATE	APVD
-	-	SEE SHEET 1	-	-

SOLDER TO PCB  
OFF - (ON)

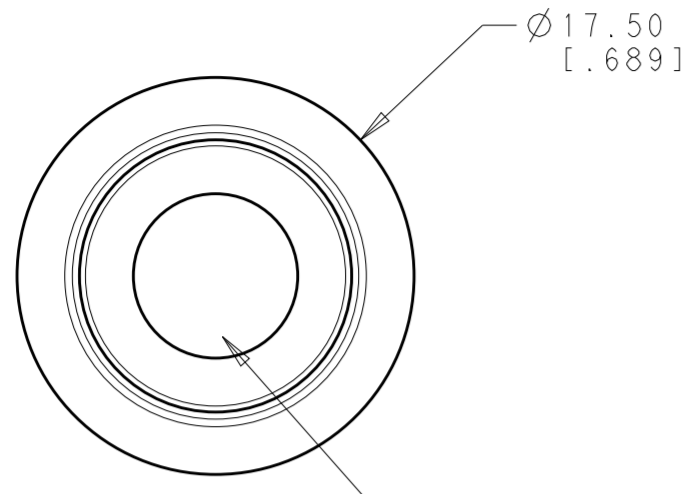

CAP COLOR: SEE TABLE

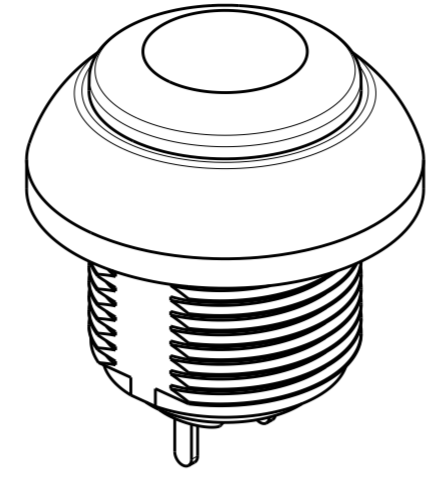

Model No.	POS. 1	POS. 2
PB6	OFF	MOM(ON)
CONNECTED TERMINALS	OPEN	CLOSE
SCHEMATIC		

SWITCH FUNCTION

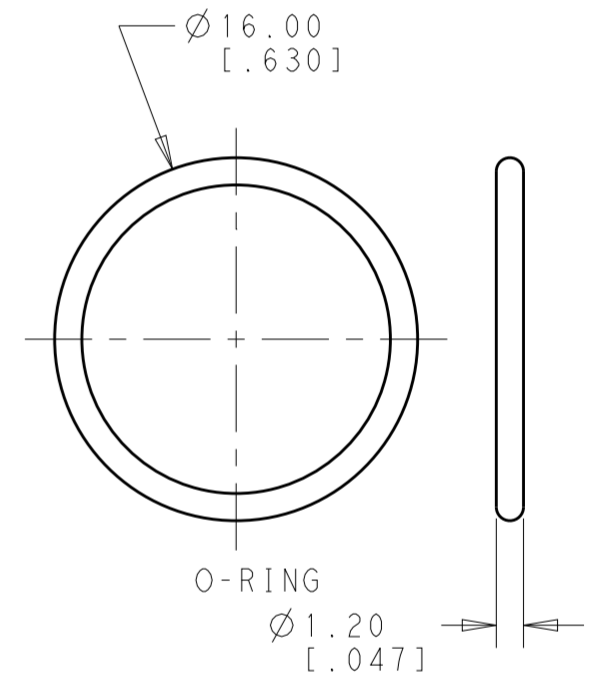
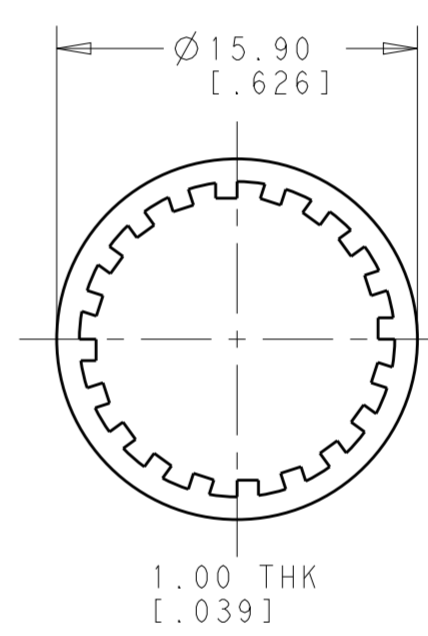
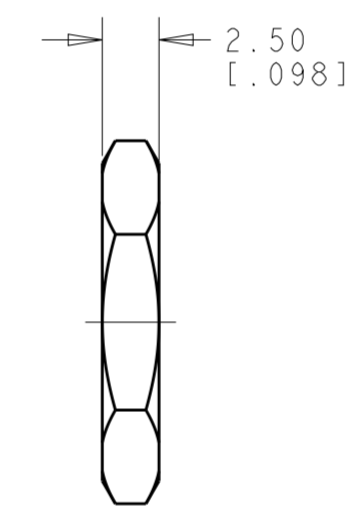
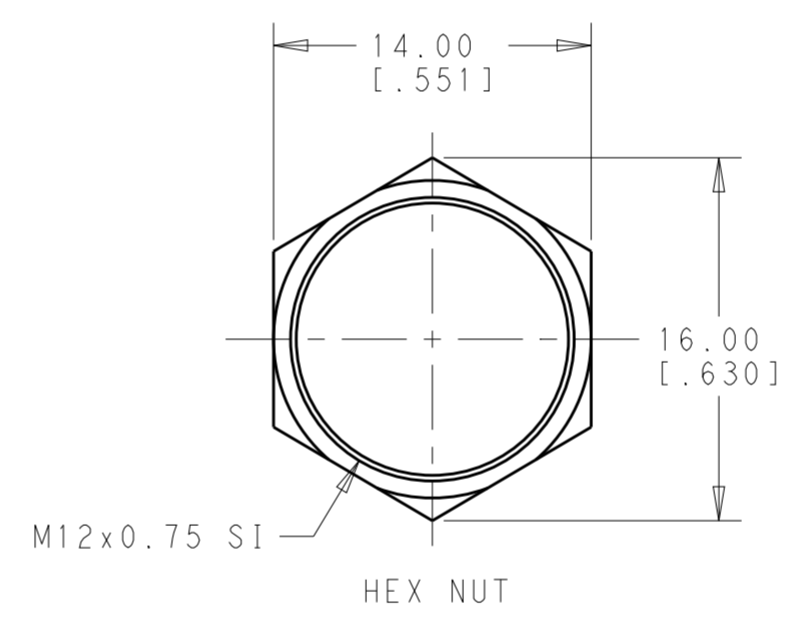
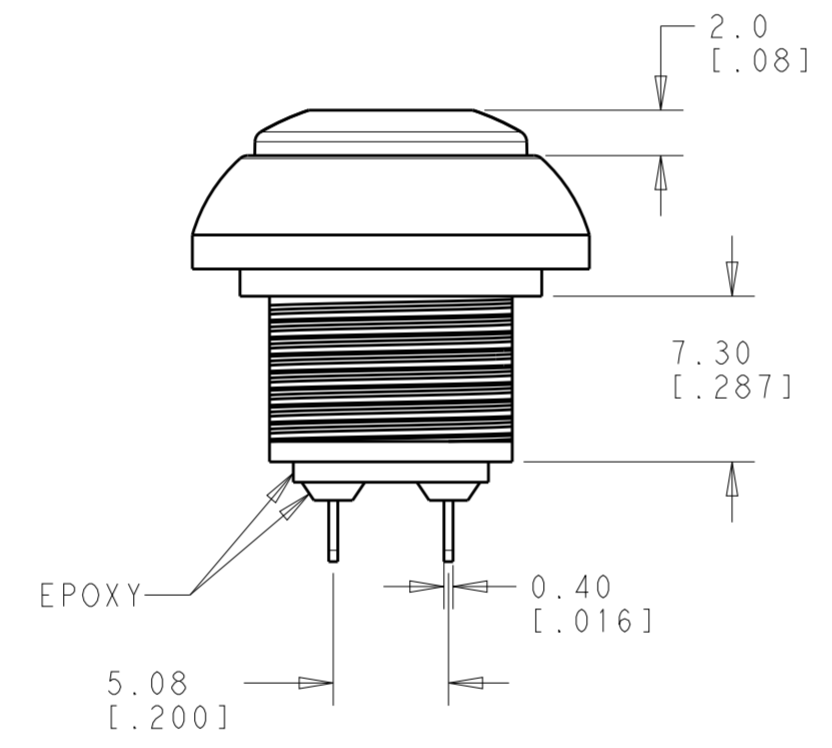
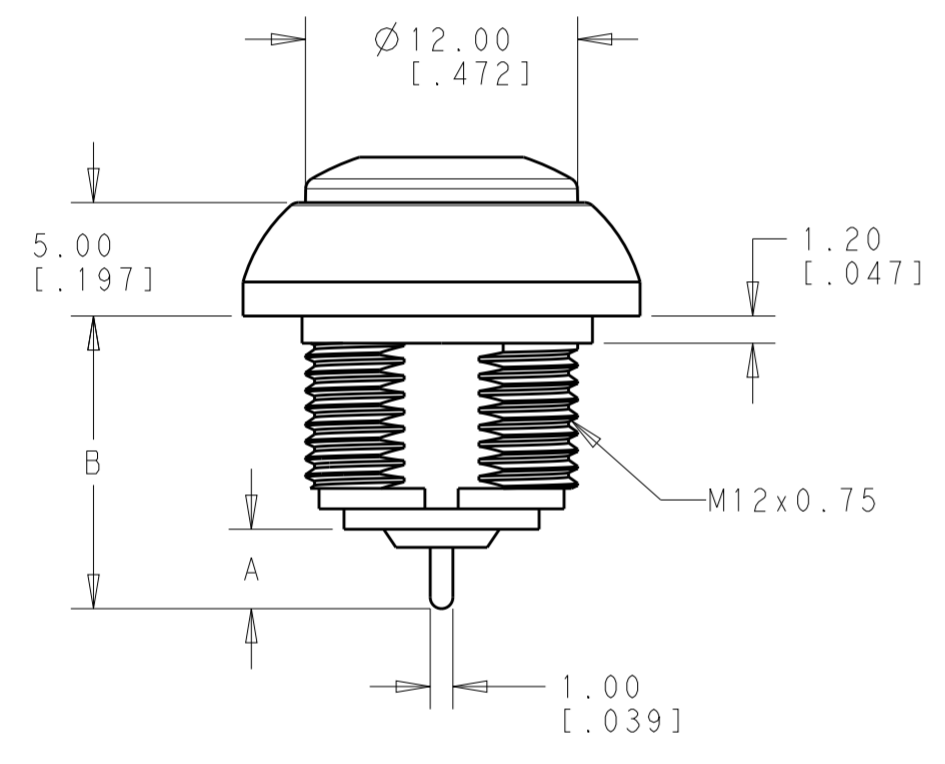

LOCK WASHER

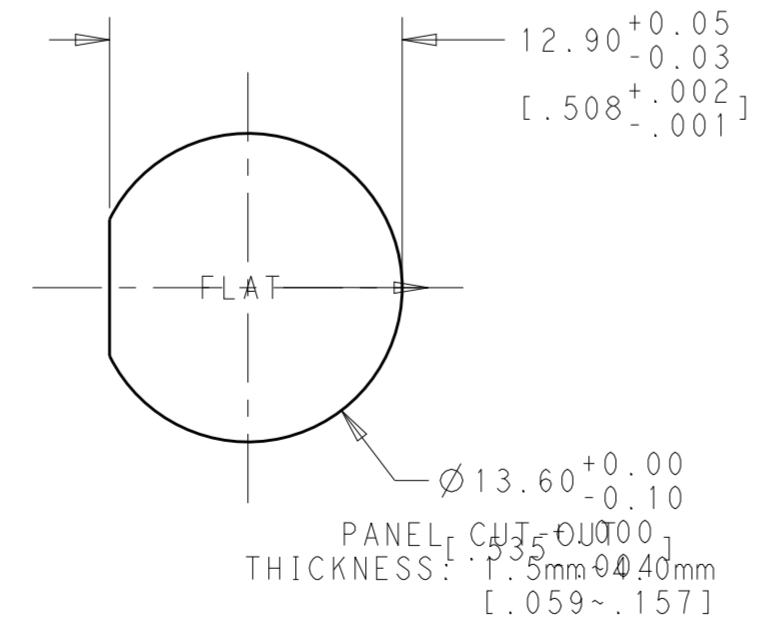
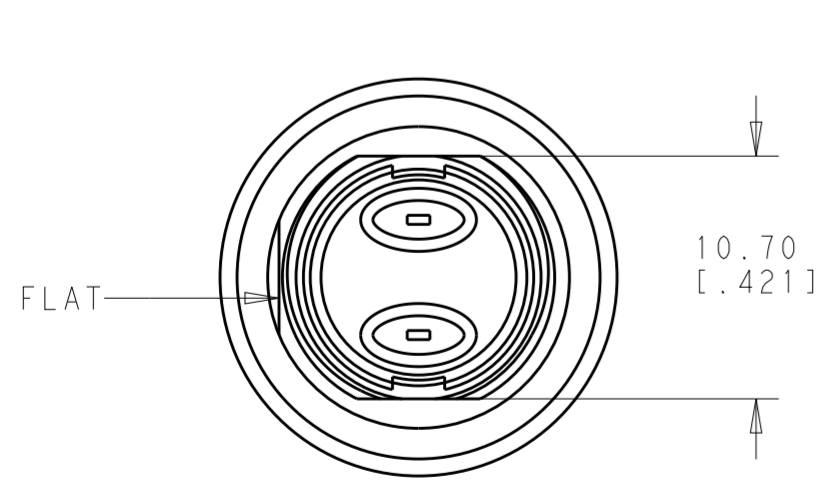

THIS DRAWING IS A CONTROLLED DOCUMENT.		DWN RAVLS 22FEB2018	TE Connectivity	
DIMENSIONS: mm [INCHES]		CHK ALEXANDER SHARPE 22FEB2018		
TOLERANCES UNLESS OTHERWISE SPECIFIED:		APVD ALEXANDER SHARPE 22FEB2018	NAME SWITCH, PUSHBUTTON, FLAT CAP NO LED, SOLDER TERMINATION, SEALED, OFF-(ON) AND ON-(OFF)	
0 PLC ±	1 PLC ±0.4 [0.016]	PRODUCT SPEC	SIZE CAGE CODE DRAWING NO. RESTRICTED TO	
2 PLC ±0.25 [0.010]	3 PLC ±	APPLICATION SPEC	A200779 C-2329383	
4 PLC ±	ANGLES ±5°	WEIGHT	SCALE 4:1 SHEET 2 OF 4 REV 2	
MATERIAL	FINISH	CUSTOMER DRAWING		

THIS DRAWING IS UNPUBLISHED. RELEASED FOR PUBLICATION  
 © COPYRIGHT copyright.d8te- ALL RIGHTS RESERVED.

REVISIONS				
P	LTR	DESCRIPTION	DATE	APVD
-		SEE SHEET 1	-	-

SOLDER TO WIRE  
ON-(OFF)

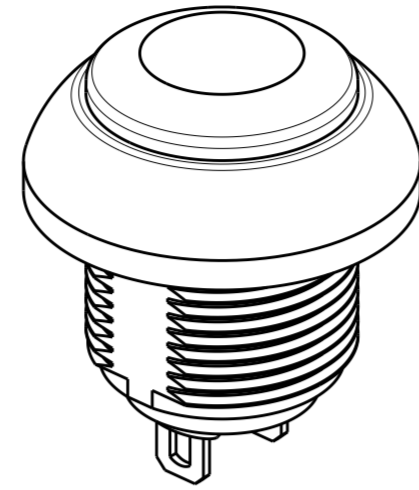
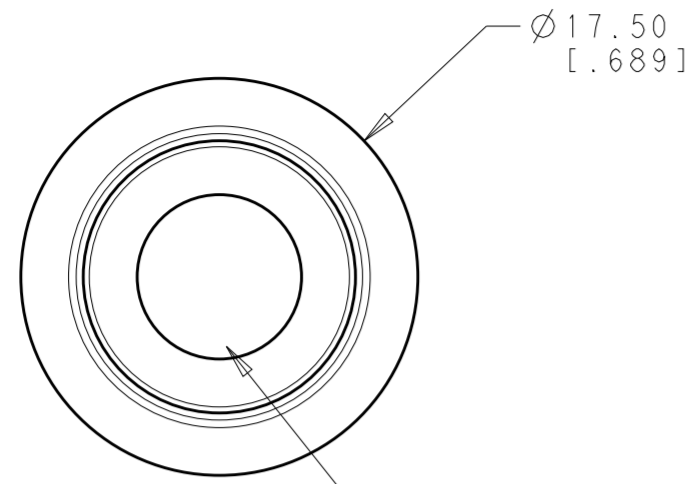

CAP COLOR: SEE TABLE

Model No.	POS. 1	POS. 2
PB7	ON	MOM(OFF)
CONNECTED TERMINALS	CLOSE	OPEN
SCHEMATIC		

SWITCH FUNCTION

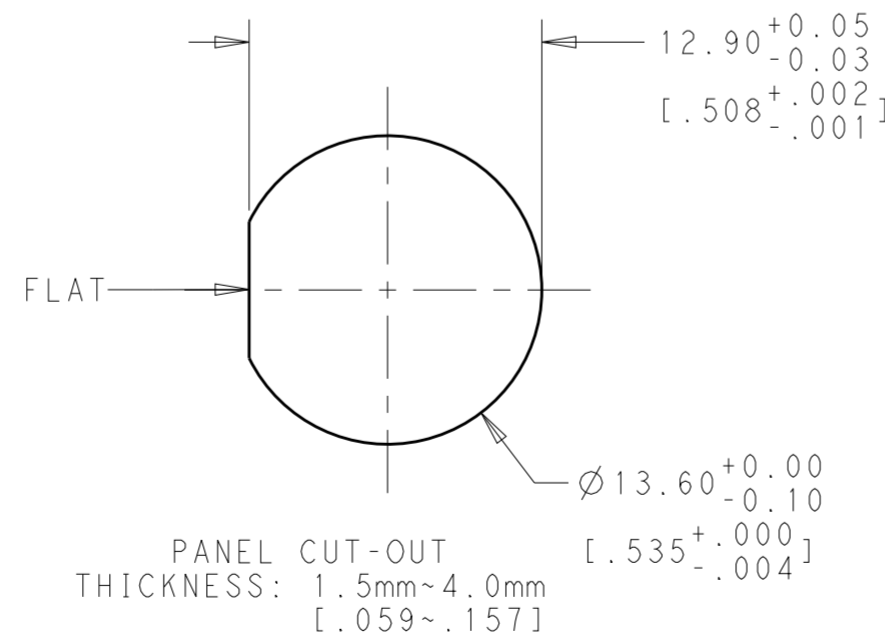
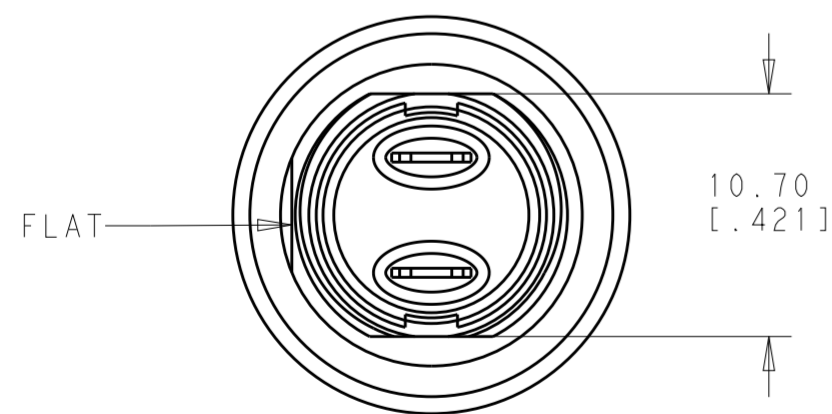
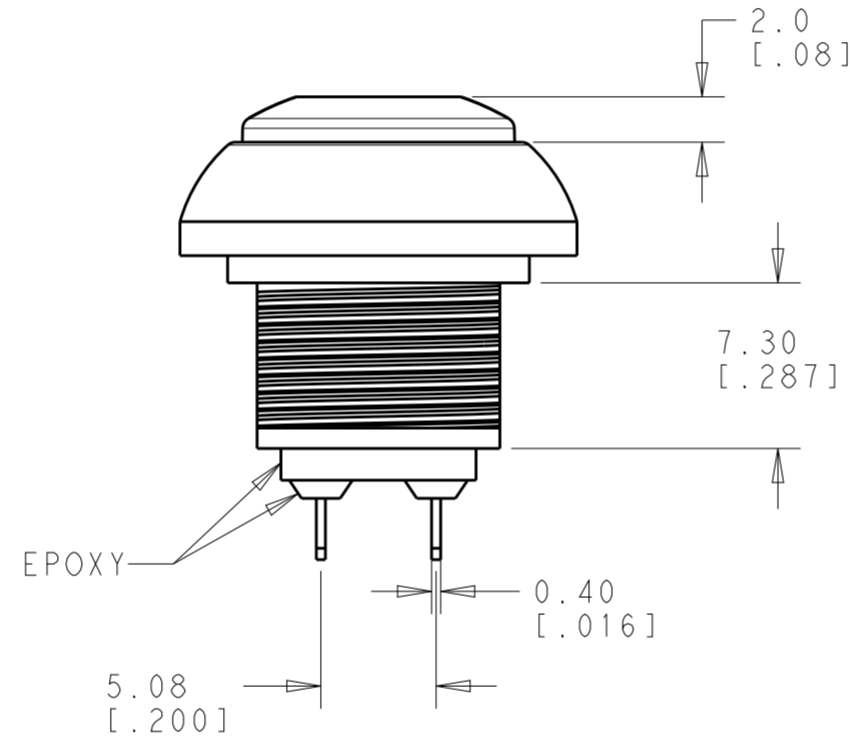
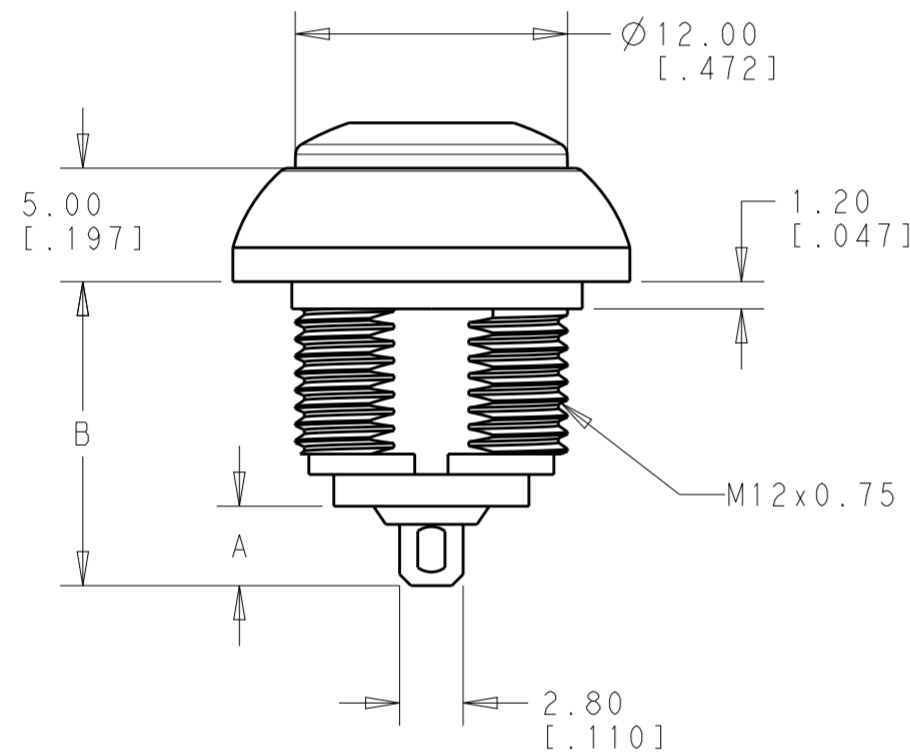

THIS DRAWING IS A CONTROLLED DOCUMENT.		DWN RAVLS 22FEB2018	TE Connectivity	
DIMENSIONS: mm [INCHES]		CHK ALEXANDER SHARPE 22FEB2018		
TOLERANCES UNLESS OTHERWISE SPECIFIED:		APVD ALEXANDER SHARPE 22FEB2018	NAME SWITCH, PUSHBUTTON, FLAT CAP NO LED, SOLDER TERMINATION, SEALED, OFF-(ON) AND ON-(OFF)	
0 PLC ±		PRODUCT SPEC	SIZE   CAGE CODE   DRAWING NO   RESTRICTED TO	
1 PLC ±0.4 [.016]		APPLICATION SPEC	A200779   C-2329383	
2 PLC ±0.25 [.010]		WEIGHT	SCALE 4:1   SHEET 3 OF 4   REV 2	
3 PLC ±		CUSTOMER DRAWING		
4 PLC ±				
ANGLES ±5°				
FINISH				

THIS DRAWING IS UNPUBLISHED. RELEASED FOR PUBLICATION  
 © COPYRIGHT copyright.dBTe ALL RIGHTS RESERVED.

REVISIONS				
P	LTR	DESCRIPTION	DATE	APVD
-		SEE SHEET 1	-	-

POLE	THROW	DIMENSION B	DIMENSION A, TERMINAL TYPE	CAP TYPE & COLOR	LED COLOR	TE DESCRIPTIVE PART NUMBER	PART NUMBER
SINGLE POLE	ON-(OFF) MOMENTARY	13.40 [.527]	3.40 [.134] SOLDER LUG (TO WIRE)	FLAT, MATTE BLUE	N/A	PB7B2FM7M1CAL00	2-2329383-5
				FLAT, MATTE GREEN	N/A	PB7B2FM6M1CAL00	2-2329383-4
				FLAT, MATTE YELLOW	N/A	PB7B2FM5M1CAL00	2-2329383-3
				FLAT, MATTE RED	N/A	PB7B2FM3M1CAL00	2-2329383-2
				FLAT, MATTE BLACK	N/A	PB7B2FM2M1CAL00	2-2329383-1
	OFF-(ON) MOMENTARY	12.90 [.508]	3.50 [.138] SOLDER POST (TO PCB)	FLAT, MATTE BLUE	N/A	PB6B2FM7M4CAL00	2-2329383-0
				FLAT, MATTE GREEN	N/A	PB6B2FM6M4CAL00	1-2329383-9
				FLAT, MATTE YELLOW	N/A	PB6B2FM5M4CAL00	1-2329383-8
				FLAT, MATTE RED	N/A	PB6B2FM3M4CAL00	1-2329383-7
				FLAT, MATTE BLACK	N/A	PB6B2FM2M4CAL00	1-2329383-6
		17.60 [.693]	8.20 [.323] SOLDER LUG (TO WIRE)	FLAT, MATTE BLUE	N/A	PB6B2FM7M3CAL00	1-2329383-5
				FLAT, MATTE GREEN	N/A	PB6B2FM6M3CAL00	1-2329383-4
				FLAT, MATTE YELLOW	N/A	PB6B2FM5M3CAL00	1-2329383-3
				FLAT, MATTE RED	N/A	PB6B2FM3M3CAL00	1-2329383-2
				FLAT, MATTE BLACK	N/A	PB6B2FM2M3CAL00	1-2329383-1
		14.90 [.587]	5.50 [.217] SOLDER LUG (TO WIRE)	FLAT, MATTE BLUE	N/A	PB6B2FM7M2CAL00	1-2329383-0
				FLAT, MATTE GREEN	N/A	PB6B2FM6M2CAL00	2329383-9
				FLAT, MATTE YELLOW	N/A	PB6B2FM5M2CAL00	2329383-8
				FLAT, MATTE RED	N/A	PB6B2FM3M2CAL00	2329383-7
				FLAT, MATTE BLACK	N/A	PB6B2FM2M2CAL00	2329383-6
12.90 [.508]	3.50 [.138] SOLDER LUG (TO WIRE)	FLAT, MATTE BLUE	N/A	PB6B2FM7M1CAL00	2329383-5		
		FLAT, MATTE GREEN	N/A	PB6B2FM6M1CAL00	2329383-4		
		FLAT, MATTE YELLOW	N/A	PB6B2FM5M1CAL00	2329383-3		
		FLAT, MATTE RED	N/A	PB6B2FM3M1CAL00	2329383-2		
		FLAT, MATTE BLACK	N/A	PB6B2FM2M1CAL00	2329383-1		

THIS DRAWING IS A CONTROLLED DOCUMENT.

DWN: RAVI.S 22FEB2018  
 CHK: ALEXANDER SHARPE 22FEB2018  
 APVD: ALEXANDER SHARPE 22FEB2018

**STE** TE Connectivity

NAME: SWITCH, PUSHBUTTON, FLAT CAP NO LED, SOLDER TERMINATION, SEALED, OFF-(ON) AND ON-(OFF)

SIZE: A2 CAGE CODE: 00779 DRAWING NO: C-2329383 RESTRICTED TO: 4

SCALE: 4:1 SHEET: 4 OF 4 REV: 2

CUSTOMER DRAWING

DIMENSIONS: mm [INCHES]	TOLERANCES UNLESS OTHERWISE SPECIFIED:
	0 PLC ± 1 PLC ±0.4 [.016] 2 PLC ±0.25 [.010] 3 PLC ± 4 PLC ±
MATERIAL	ANGLES ±5° FINISH