

注記 ( NOTE ) :

- 材質 MATERIAL  
 ハウジング: ポリアミド ( PA ) , ナチュラル ( 白色 ) , ガラス充填 , UL94V-0  
 HOUSING: POLYAMIDE, NATURAL(WHITE), GLASS FILLED, UL94V-0  
 アクチュエータ: ポリフェニレンサルファイド(PPS), ナチュラル ( 茶色 ) , ガラス充填 , UL94V-0  
 ACTUATOR: POLYPHENYLENE SULFIDE, NATURAL(BROWN), GLASS FILLED, UL94V-0  
 ターミナル: リン青銅 ( t=0.32 )  
 TERMINAL: PHOSPHOR BRONZE ( t=0.32 )  
 ネイル(補強金具): リン青銅 ( t=0.25 )  
 FITTING NAIL: PHOSPHOR BRONZE ( t=0.25 )
- めっき仕様 PLATING  
 ターミナル TERMINAL  
 錫銀ビスマスめっき ( 1.0μm以上 )  
 TIN SILVER BISMUTH PLATING ( 1.0 MICROMETER MINIMUM )  
 下地: ニッケルめっき ( 1.0μm以上 )  
 UNDER PLATE: NICKEL PLATING ( 1.0 MICROMETER MINIMUM )  
 ネイル ( 補強金具 ) FITTING NAIL  
 錫めっき ( 1.0μm以上 )  
 TIN PLATING ( 1.0 MICROMETER MINIMUM )  
 下地: ニッケルめっき ( 1.0μm以上 )  
 UNDER PLATE: NICKEL PLATING ( 1.0 MICROMETER MINIMUM )
- △3 C0.3はFPC/FFCの導体部にかからないこと  
 C0.3 MUST NOT BE OVERLAPED TO PATTERN OF FPC/FFC.
- △4 エンボスターン包時は、アクチュエータがロックした状態とする。  
 IN THE PACKAGE, ACTUATOR SHOULD BE LOCKED.
- △5 パターン剥離止め用金具  
 FITTING NAIL FOR PREVENTION OF PEELING OF P.C.B. PATTERN.
- △6 ソルダーテール半田付け面、及び金具半田付け面の平坦度: 0.15mm MAX.  
 COPLANARITY OF SOLDER TAILS AND FITTING NAILS TO BE 0.15mm MAX.
- ELV及びRoHS適合品  
 ELV AND RoHS COMPLIANT

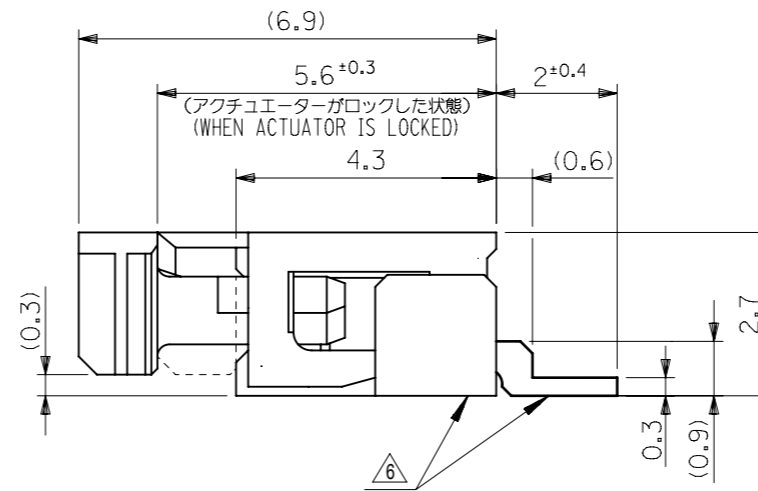

38.7	35.2	33	52207-3433	34
34.7	31.2	29	52207-3033	30
33.7	30.2	28	52207-2933	29
32.7	29.2	27	52207-2833	28
31.7	28.2	26	52207-2733	27
30.7	27.2	25	52207-2633	26
29.7	26.2	24	52207-2533	25
28.7	25.2	23	52207-2433	24
27.7	24.2	22	52207-2333	23
26.7	23.2	21	52207-2233	22
25.7	22.2	20	52207-2133	21
24.7	21.2	19	52207-2033	20
23.7	20.2	18	52207-1933	19
22.7	19.2	17	52207-1833	18
21.7	18.2	16	52207-1733	17
20.7	17.2	15	52207-1633	16
19.7	16.2	14	52207-1533	15
18.7	15.2	13	52207-1433	14
17.7	14.2	12	52207-1333	13
16.7	13.2	11	52207-1233	12
15.7	12.2	10	52207-1133	11
14.7	11.2	9	52207-1033	10
13.7	10.2	8	52207-0933	9
12.7	9.2	7	52207-0833	8
11.7	8.2	6	52207-0733	7
10.7	7.2	5	52207-0633	6
9.7	6.2	4	52207-0533	5
8.7	5.2	3	52207-0433	4
7.7	4.2	2	52207-0333	3
C	B	A	EMBOSSED PACKAGE ORDER NO. オーダー番号	極数 CKT.
CONNECTOR SERIES NO.: 52207-**22				

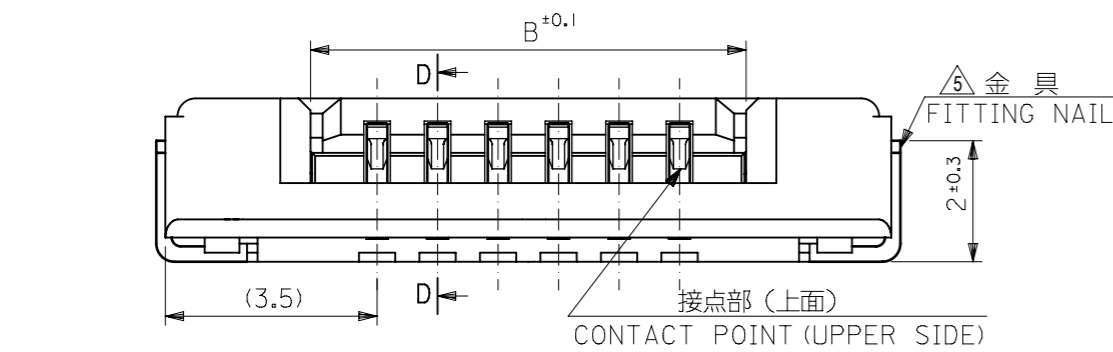
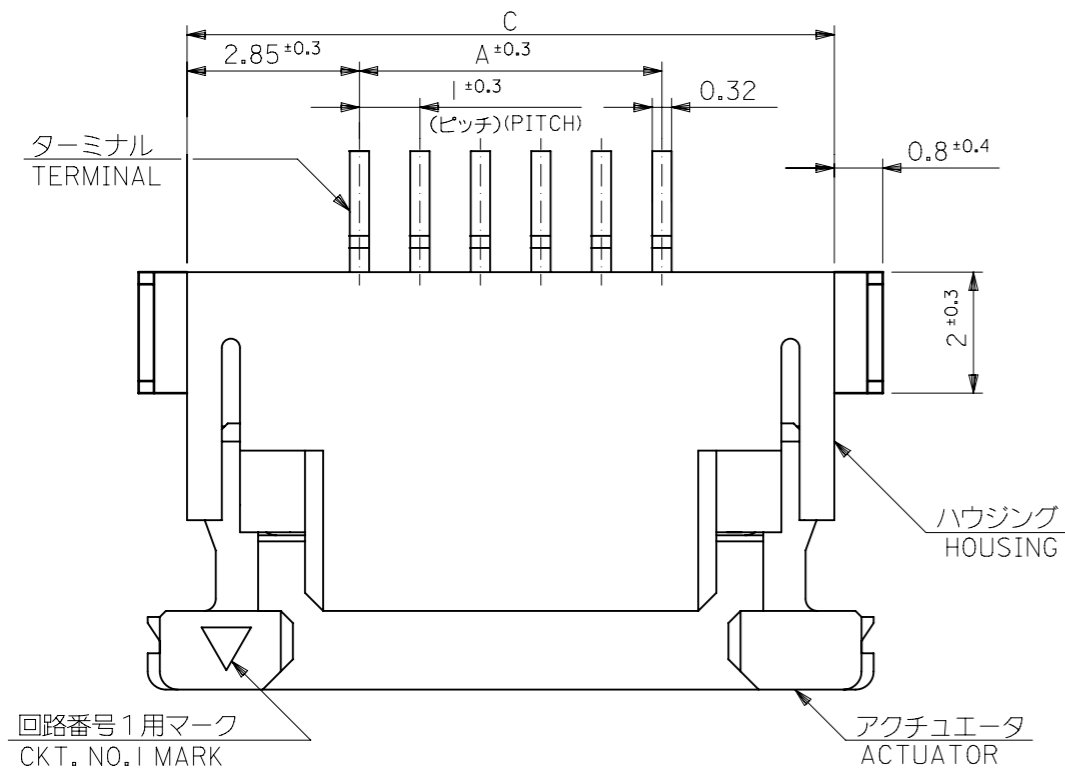
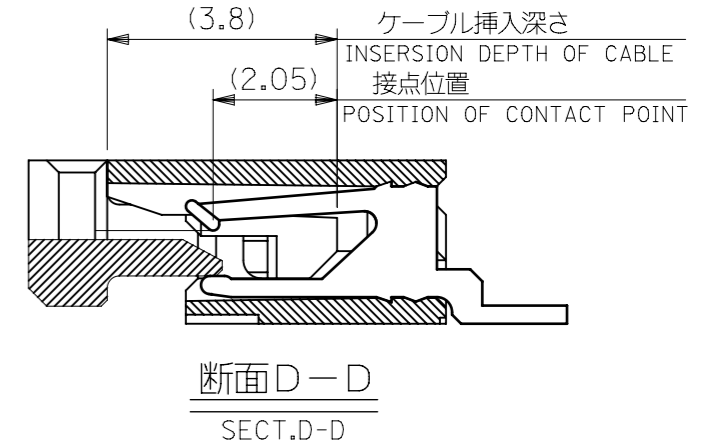
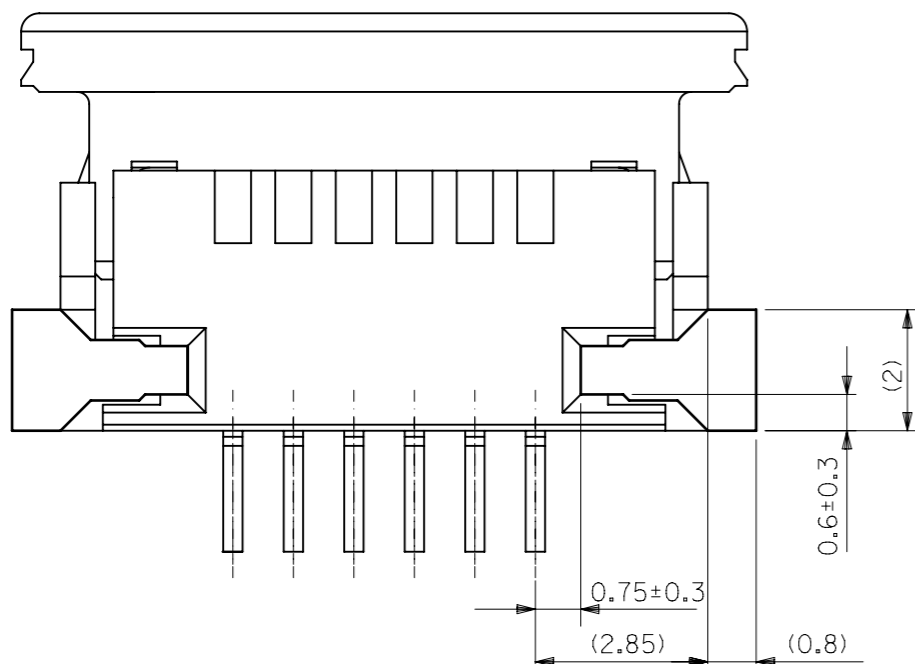

GENERAL TOLERANCES (UNLESS SPECIFIED)	
10 UNDER	± 0.2
10 OVER 30 UNDER	± 0.25
30 OVER	± 0.3
ANGULAR ± 3 °	
DRAFT WHERE APPLICABLE MUST REMAIN WITHIN DIMENSIONS	

THIS DRAWING CONTAINS INFORMATION THAT IS PROPRIETARY TO MOLEX ELECTRONIC TECHNOLOGIES, LLC AND SHOULD NOT BE USED WITHOUT WRITTEN PERMISSION

DIMENSION UNITS: mm SCALE: 8:1

CURRENT REV DESC: REVISED

EC NO: 600129  
 DRWN: YCHEN128 2018/04/11  
 CHK'D: KTAKAHASHI 2018/04/12  
 APPR: NUKITA 2018/04/13

INITIAL REVISION:  
 DRWN: NASANUMA 2012/09/21  
 APPR: KMORIKAWA 2013/03/15

THIRD ANGLE PROJECTION

DRAWING: A3-SIZE SERIES: 52207

MATERIAL NUMBER: SEE TABLE CUSTOMER: GENERAL MARKET SHEET NUMBER: 1 OF 2

DOCUMENT NUMBER: SD-52207-069 DOC TYPE: PSD DOC PART: 001 REVISION: C

**molex**

1.0 MM FPC CONN. ZIF R/A  
HOUSING ASSY (UPPER CONTACT)

PRODUCT CUSTOMER DRAWING

DOCUMENT STATUS: P1 RELEASE DATE: 2018/04/13 03:50:55

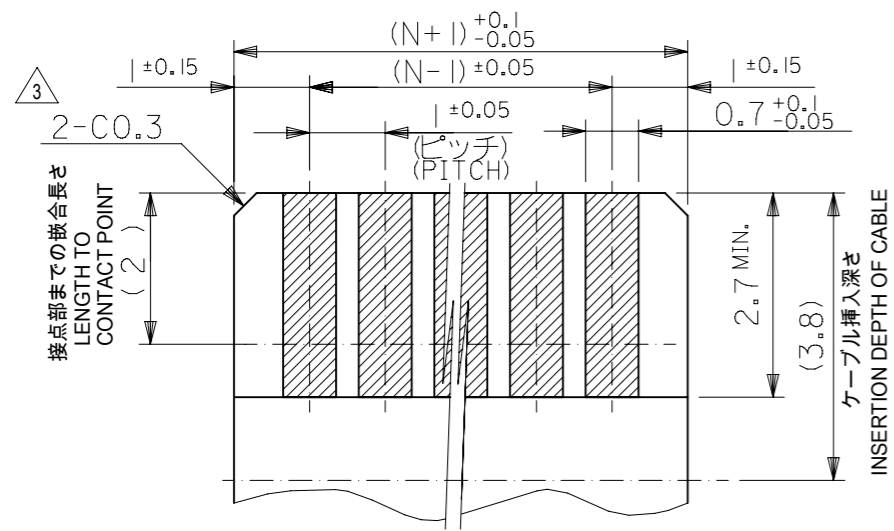

**適合FPC/FFC推奨寸法**  
 APPLICABLE FPC/FFC  
 RECOMMENDED DIMENSION  
 (仕上り厚さ: 0.3 ±0.05)  
 (THICKNESS: 0.3 ±0.05)

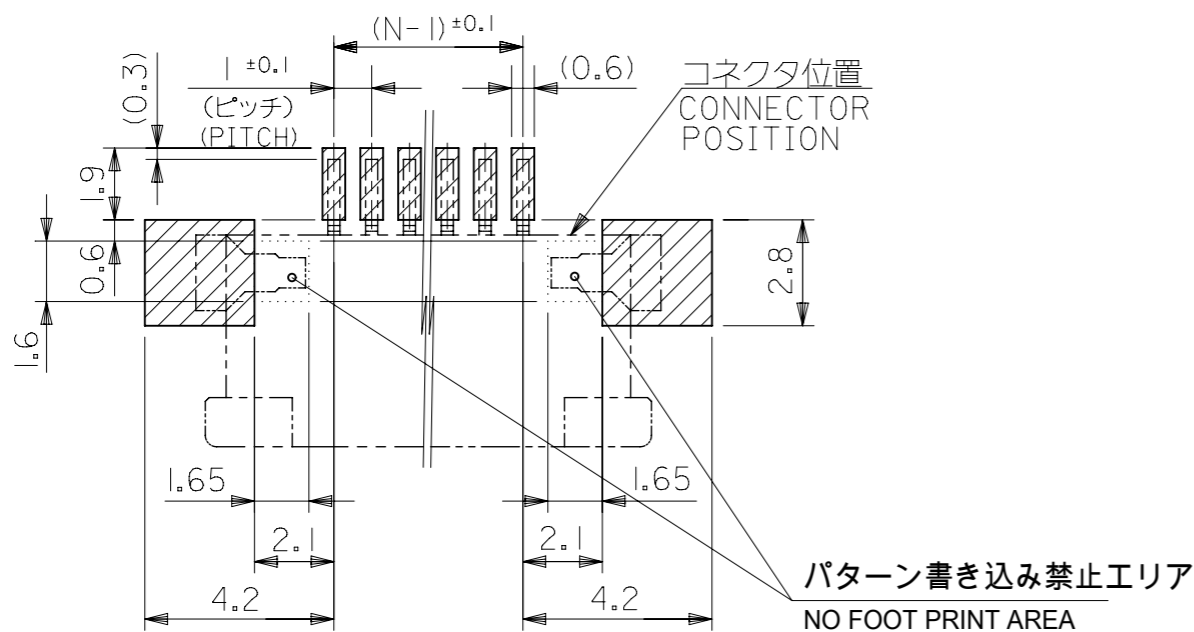

**推奨基板レイアウト**  
 RECOMMENDED P.C. BOARD  
 PATTERN DIMENSION.(REF.)  
 (マウント面)  
 (MOUNT SIDE)

マスク厚 : 100µm  
 マスク開口率 : 100%  
 SCREEN THICKNESS : 100 MICROMETER  
 SCREEN OPEN RATIO : 100%

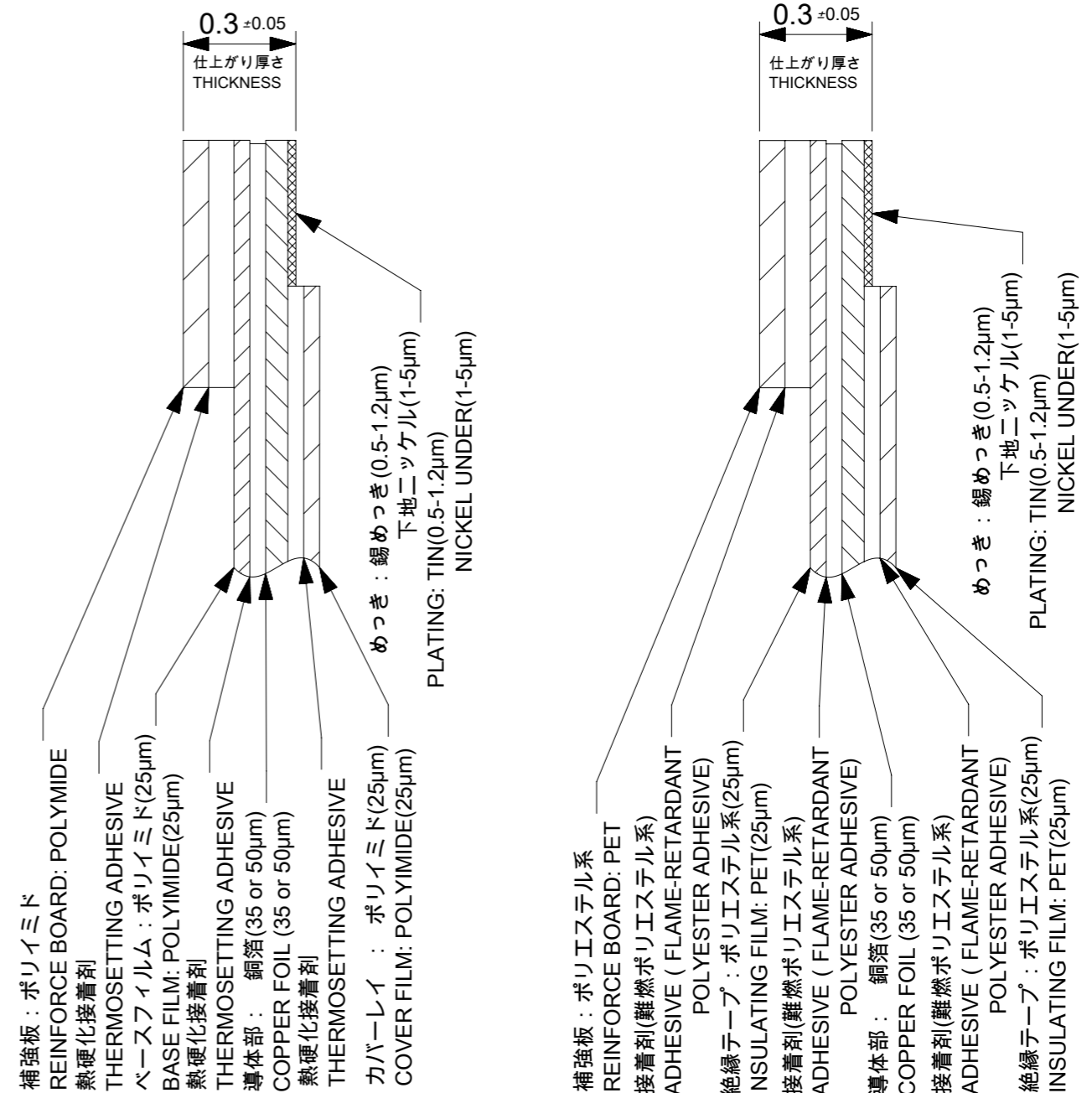

**FPC構成推奨仕様**  
 RECOMMENDED STRUCTURE OF FPC

**FFC構成推奨仕様**  
 RECOMMENDED STRUCTURE OF FFC

FPC/FFCについて:  
 抜き方向は、導体側から補強板側を推奨致します。  
 尚、接着剤の接点部への付着は導通不良の原因になりますので、  
 染み出しが無い様お願い致します。

ABOUT FPC/FFC:  
 RECOMMENDED PUNCHER DIRECTION:  
 FROM CONDUCTOR SIDE TO STIFFNER SIDE  
 PLEASE PUT APPROPRIATE AMOUNT OF ADHESIVE ON ADHEREND  
 BECAUSE THERE IS A POSSIBILITY THAT THE EXTRA ADHESIVE  
 CAUSES THE DEFECT IN ELECTRICAL CONTINUITY.

THIS DRAWING CONTAINS INFORMATION THAT IS PROPRIETARY TO MOLEX ELECTRONIC TECHNOLOGIES, LLC AND SHOULD NOT BE USED WITHOUT WRITTEN PERMISSION

GENERAL TOLERANCES (UNLESS SPECIFIED)	
10 UNDER	± 0.2
10 OVER 30 UNDER	± 0.25
30 OVER	± 0.3
ANGULAR	± 3 °
DRAFT WHERE APPLICABLE MUST REMAIN WITHIN DIMENSIONS	

DIMENSION UNITS	SCALE
mm	5:1
GENERAL TOLERANCES (UNLESS SPECIFIED)	
ANGULAR TOL	± 30 °
4 PLACES	± 0.2
3 PLACES	± 0.25
2 PLACES	± 0.3
1 PLACE	±
0 PLACES	±
DRAFT WHERE APPLICABLE MUST REMAIN WITHIN DIMENSIONS	

CURRENT REV DESC: REVISED		<b>molex</b>	
EC NO: 600129	2018/04/11		
DRWN: YCHEN128	2018/04/12	1.0 MM FPC CONN. ZIF R/A HOUSING ASSY (UPPER CONTACT)	
CHK'D: KTAKAHASHI	2018/04/13	PRODUCT CUSTOMER DRAWING	
APPR: NUKITA		DOCUMENT NUMBER	
INITIAL REVISION:		DOC TYPE	
DRWN: NASANUMA	2012/09/21	DOC PART	
APPR: KMORIKAWA	2013/03/15	REVISION	
THIRD ANGLE PROJECTION		SD-52207-069	
DRAWING	SERIES	MATERIAL NUMBER	CUSTOMER
A3-SIZE	52207	SEE TABLE	GENERAL MARKET
SHEET NUMBER		2 OF 2	

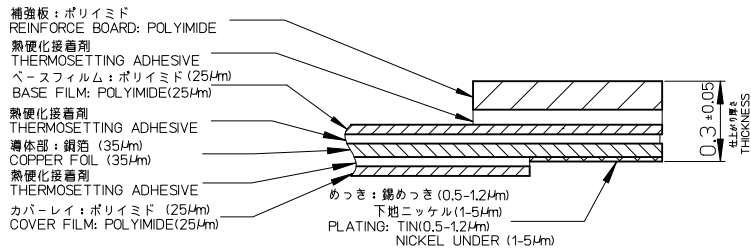
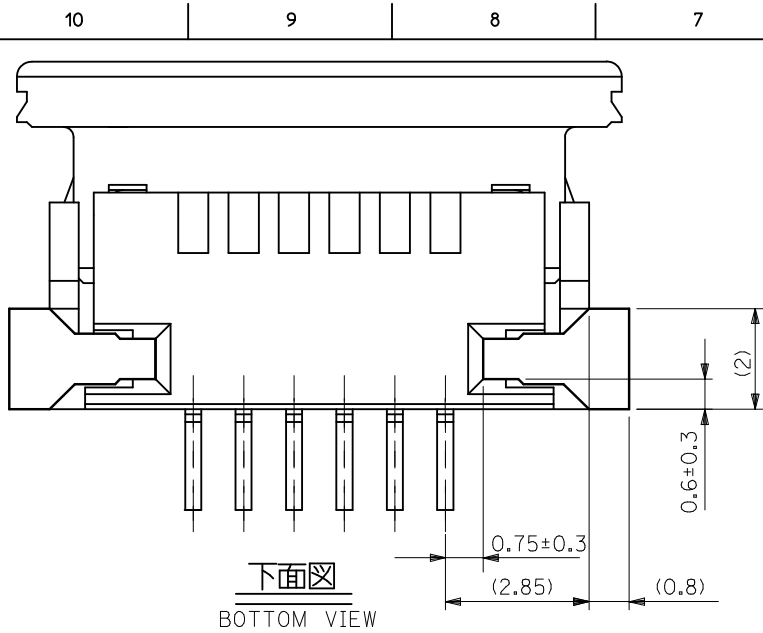

FPC構成推奨仕様  
STRUCTURE OF FPC

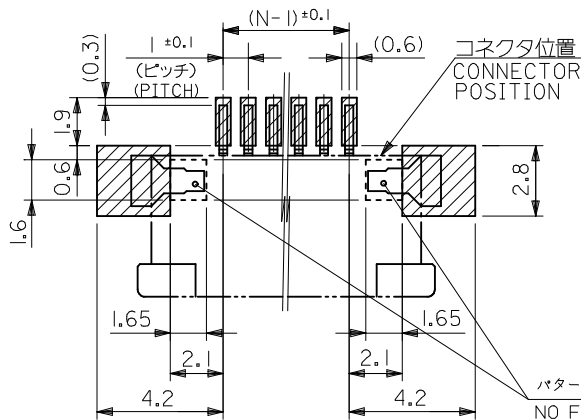

推奨基板レイアウト  
RECOMMENDED P.C.BOARD  
PATTERN DIMENSION(REF.)  
(マウント面)  
(MOUNT SIDE)  
マスク厚 : 100 µm  
マスク開口率 : 100%  
SCREEN THICKNESS : 100 MICROMETER  
SCREEN OPEN RATIO : 100%

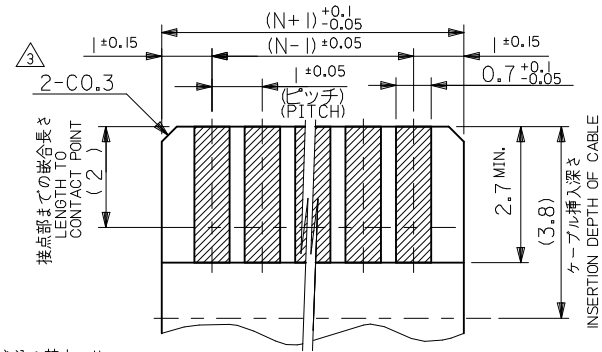

適合FPC/FFC推奨寸法  
APPLICABLE FPC/FFC  
RECOMMENDED DIMENSION  
(仕上り厚さ: 0.3±0.05)  
(THICKNESS: 0.3±0.05)

FPC/FFCについて ABOUT FPC/FFC

打ち抜き方向は導体側から補強板側を推奨します。  
導体部については軟箔銅35µmまたは50µmを推奨します。

RECOMMENDED PUNCHING DIRECTION: FROM CONDUCTOR SIDE TO STIFFENER SIDE  
RECOMMENDED CONDUCTOR SPEC: SOFT COPPER FOIL  
RECOMMENDED CONDUCTOR THICKNESS: 35 MICROMETER OR 50 MICROMETER

FPCについて ABOUT FPC

補強フィルム材質はポリイミドを推奨します。ベースフィルムは25µmを推奨します。  
接着剤は熱硬化接着剤を推奨します。  
尚、接着剤の接点部への付着は導通不良の原因になりますので、染み出しが無い様、お願い致します。

RECOMMENDED STIFFENER MATERIAL: POLYIMIDE  
RECOMMENDED BASE FILM THICKNESS: 25 MICROMETER  
RECOMMENDED ADHESIVE: THERMOSETTING ADHESIVE  
NOTE: PLEASE PUT APPROPRIATE AMOUNT OF ADHESIVE ON ADHEREND BECAUSE THERE IS A POSSIBILITY THAT THE EXTRA ADHESIVE CAUSES THE DEFECT IN ELECTRICAL CONTINUITY.

SEE SHEET 1 OF 2 EC NO: J2014-0096 DRAWN: AISHI 2013/07/18 CHKD: TAKAHASHI 2013/07/18 APPR: YNOGAWA 2013/08/19	DESCRIPTION	GENERAL TOLERANCES (UNLESS SPECIFIED)		DIMENSION STYLE MM ONLY		SCALE ---	DESIGN UNITS METRIC	THIRD ANGLE PROJECTION	
		10 UNDER	±0.2	DRAWN BY JOKAMURA	DATE 2012/09/10	TITLE 1.0 MM FPC CONN. ZIF R/A HOUSING ASSY (UPPER CONTACT)			
		10 OVER 30 UNDER	±0.25	CHECKED BY KTAKAHASHI	DATE 2012/09/11				
		30 OVER	±0.3	APPROVED BY KMORIKAWA	DATE 2013/03/15				
REV	ANGULAR ±3 °	DRAFT WHERE APPLICABLE MUST REMAIN WITHIN DIMENSIONS		MATERIAL NO. SEE CHART		DOCUMENT NO. SD-52207-069	SHEET NO. 2 OF 2		
SIZE A3		THIS DRAWING CONTAINS INFORMATION THAT IS PROPRIETARY TO MOLEX INCORPORATED AND SHOULD NOT BE USED WITHOUT WRITTEN PERMISSION							

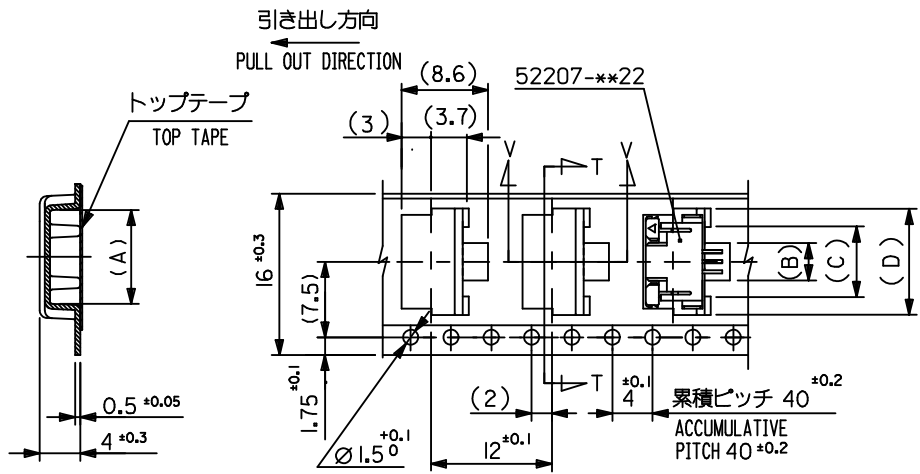

SECT:T-T

16mm 幅 キャリアテープ  
16mm WIDTH CARRIER TAPE

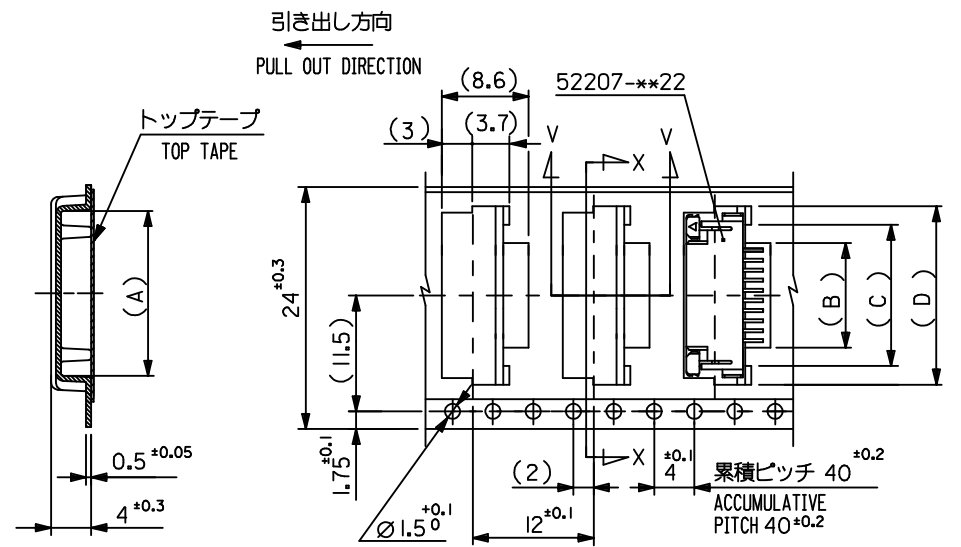

SECT:X-X

24mm 幅 キャリアテープ  
24mm WIDTH CARRIER TAPE

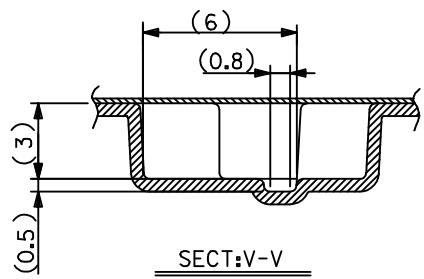

SECT:V-V

24	29.4	25.4	18.5	15	11.7	17.3	52207-1133	11	
			17.5	14	10.7	16.3	4 -1033	10	
			16.5	13	9.7	15.3	-0933	9	
			15.5	12	8.7	14.3	-0833	8	
			14.5	11	7.7	13.3	-0733	7	
			13.5	10	6.7	12.3	-0633	6	
			12.5	9	5.7	11.3	-0533	5	
			11.5	8	4.7	10.3	7 -0433	4	
52207-**-33	16	21.4	17.4	10.5	7	3.7	9.3	52207-0333	3
MODEL NO.	キャリアテープ幅 CARRIER TAPE WIDTH	H	E	(D)	(C)	(B)	(A)	MATERIAL NO.	極致 CKT.

RELEASED EC NO: J2013-1002 DRWN:NASUNUMA 2012/09/21 CHKD:KAKAHASHI 2013/03/14 APPR:KMORIKAWA 2013/03/15	GENERAL TOLERANCES (UNLESS SPECIFIED)		DIMENSION STYLE MM ONLY		SCALE ---	DESIGN UNITS METRIC	THIRD ANGLE PROJECTION	
	10 UNDER	±0.2	DRAWN BY	DATE	TITLE			
	10 OVER 30 UNDER	±0.25	NASANUMA	2012/09/21	EMBOSS TAPE PACKAGED FOR 1.0 MM FPC CONN ZIF R/A HOUSING ASSY			
	30 OVER	±0.3	CHECKED BY	DATE	<b>molex</b> DOCUMENT NO. SD-52207-070 SHEET NO. 1 OF 3			
	ANGULAR ±3 °		APPROVED BY	DATE				
DRAFT WHERE APPLICABLE MUST REMAIN WITHIN DIMENSIONS		KMORIKAWA	2013/03/15	SEE CHART				
		MATERIAL NO.		THIS DRAWING CONTAINS INFORMATION THAT IS PROPRIETARY TO MOLEX INCORPORATED AND SHOULD NOT BE USED WITHOUT WRITTEN PERMISSION				

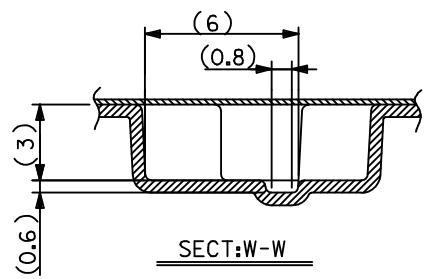
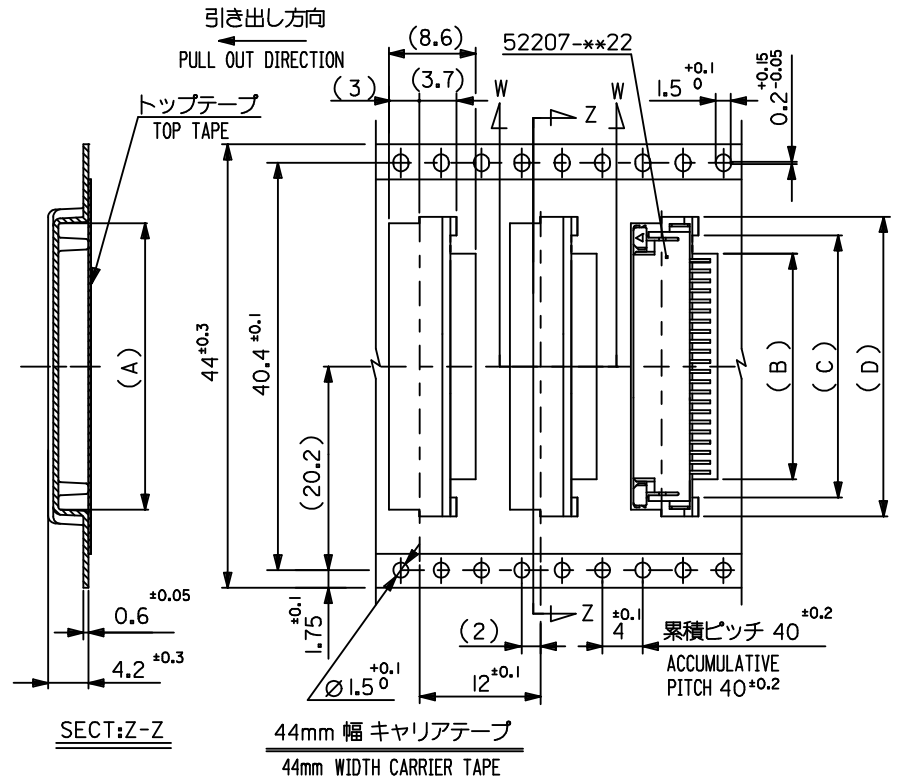
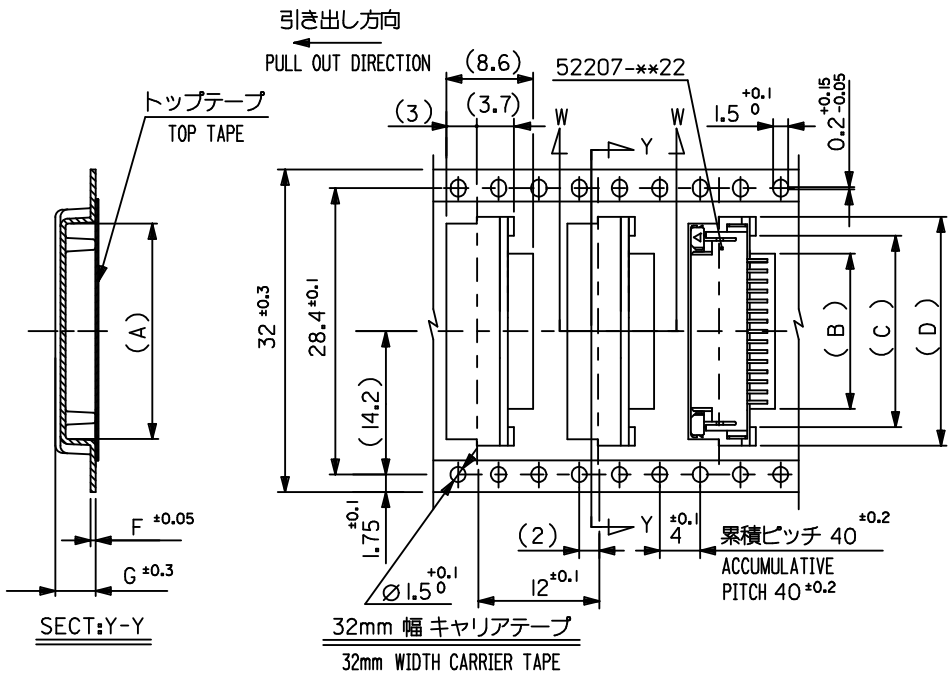

32	37.4	33.4	4.0	0.5	23.5	20	16.7	22.35	52207-1633	16
			4.2	0.6	22.5	19	15.7	21.35	4-1533	15
			4.2	0.6	21.5	18	14.7	20.35	-1433	14
			4.2	0.6	20.5	17	13.7	19.35	7-1333	13
			4.2	0.6	19.5	16	12.7	18.35	52207-1233	12
キャリアテープ幅 CARRIER TAPE WIDTH	H	E	(G)	(F)	(D)	(C)	(B)	(A)	MATERIAL NO.	極数 CKT.

44	49.4	45.4	34.5	31	27.7	33.35	52207-2733	27
			33.5	30	26.7	32.35	4-2633	26
			32.5	29	25.7	31.35	-2533	25
			31.5	28	24.7	30.35	-2433	24
			30.5	27	23.7	29.35	-2333	23
			29.5	26	22.7	28.35	-2233	22
			28.5	25	21.7	27.35	-2133	21
			27.5	24	20.7	26.35	-2033	20
			26.5	23	19.7	25.35	-1933	19
			25.5	22	18.7	24.35	7-1833	18
			24.5	21	17.7	23.35	52207-1733	17
キャリアテープ幅 CARRIER TAPE WIDTH	H	E	(D)	(C)	(B)	(A)	MATERIAL NO.	極数 CKT.

SEE SHEET 1 OF 3 EC NO.: J2013-1002 DRWN:NASUNUMA 2012/09/21 CHKD:KAKAHASHI 2013/03/14 APPR:KMORIKAWA 2013/03/15	GENERAL TOLERANCES (UNLESS SPECIFIED)	DIMENSION STYLE MM ONLY	SCALE ---	DESIGN UNITS METRIC	THIRD ANGLE PROJECTION
	10 UNDER ± 0.2	DRAWN BY NASUNUMA	DATE 2012/09/21	TITLE EMBOSSD TAPE PACKAGED 1.0 MM FPC CONN ZIF R/A HOUSING ASSY	
	10 OVER 30 UNDER ± 0.25	CHECKED BY KAKAHASHI	DATE 2013/03/14		
	30 OVER ± 0.3	APPROVED BY KMORIKAWA	DATE 2013/03/15		
ANGULAR ± 3 °	DRAFT WHERE APPLICABLE MUST REMAIN WITHIN DIMENSIONS		SEE CHART	DOCUMENT NO. SD-52207-070	SHEET NO. 2 OF 3
0	THIS DRAWING CONTAINS INFORMATION THAT IS PROPRIETARY TO MOLEX INCORPORATED AND SHOULD NOT BE USED WITHOUT WRITTEN PERMISSION				

注記

- 製品番号52207-\*\*-\*\*22の梱包状態は、アクチュエータがロックした状態とする。  
 詳細寸法については、図面SD-52207-069を参照ください  
 IN THE PACKAGE, ACTUATOR OF PART NO.52207-\*\*-\*\*22 SHOULD BE LOCKED  
 RE DETAILED DIMENSIONS, SEE SD-52207-069.
- 梱包数量：1000個/リール  
 NUMBER OF CONNECTORS : 1000PCS/REEL
- リードテープ長さ(LEAD TAPE LENGTH)  
 トップテープ TOP TAPE                      トップテープ TOP TAPE  
 リーダー部 LEADER PART                      未接着部 NON-BONDED PART  

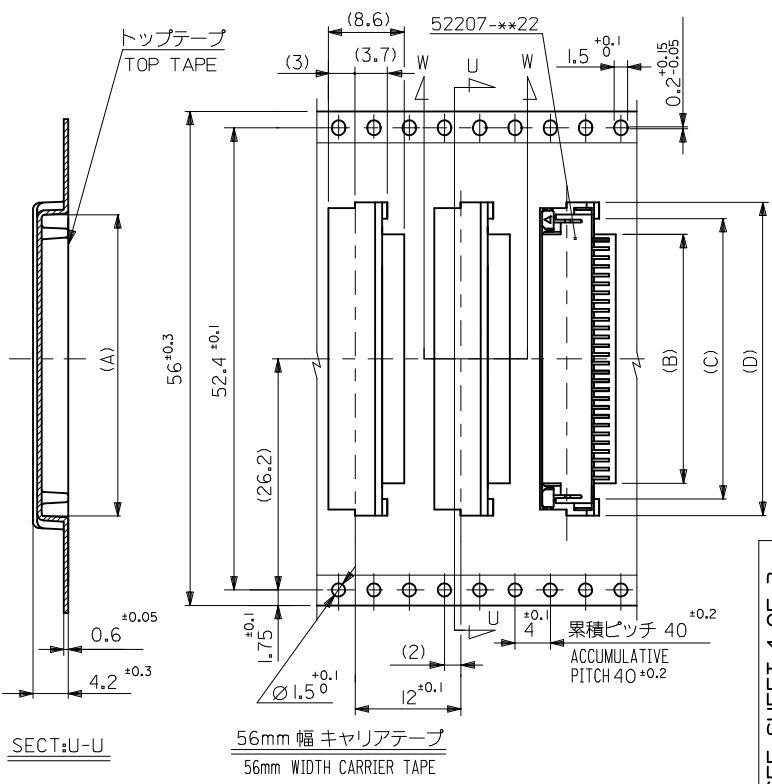
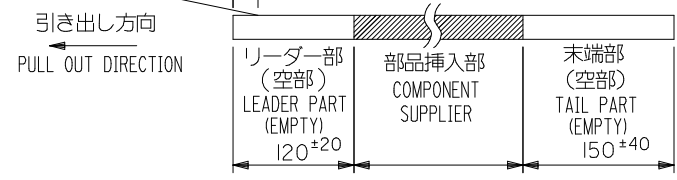
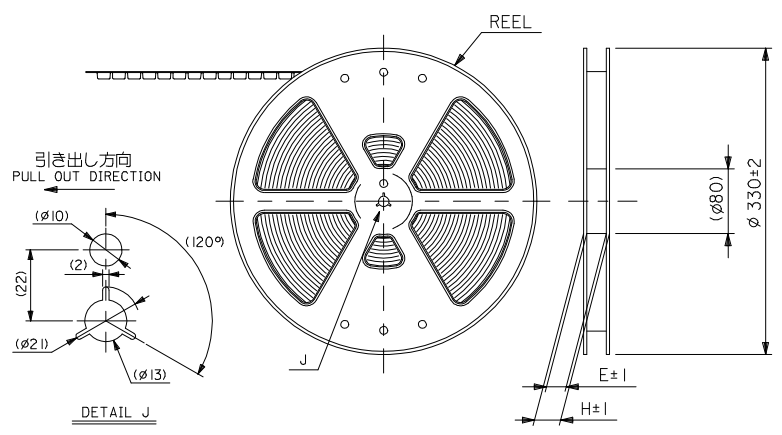
- カバーテープの剥離強度については、IEC60286-3に準拠  
 COVER TAPE PEEL FORCE IS DEFINED BY IEC60286-3.
- 材料 (MATERIAL)  
 キャリアテープ (CARRIER TAPE) : ポリプロピレン (POLYPROPYLENE)  
 トップテープ (TOPTAPE) : PET, PE, PEF  
 リール (REEL) : ポリスチレン (PS) <リサイクル材を含む>  
 POLYSTYRENE (PS) <RECYCLE MATERIAL CONTAINED>
- 本製品は乾燥剤入り、ハイバリア梱包仕様である。  
 THIS PRODUCT IS HIGH BARRIER PACKAGE WITH DESICCANT.
- ELV及びRoHS適合品  
 ELV AND RoHS COMPLIANT.



52207-**-**33	MODEL NO.	キャリアテープ幅 CARRIER TAPE WIDTH	H	E	(D)	(C)	(B)	(A)	56	61.4	57.4	41.5	38	34.7	40.35	52207-3433	34
									37.5	34	30.7	36.35	52207-3033	30			
									36.5	33	29.7	35.35	52207-2933	29			
									35.5	32	28.7	34.35	52207-2833	28			
															MATERIAL NO.	極致 CKT.	

SEE SHEET 1 OF 3

EC NO: J2013-1002  
 DRWN:NASUNUMA 2012/09/21  
 CHKD:KAKAHASHI 2013/03/14  
 APPR:KMORIKAWA 2013/03/15

GENERAL TOLERANCES (UNLESS SPECIFIED)

10 UNDER	±0.2
10 OVER 30 UNDER	±0.25
30 OVER	±0.3

ANGULAR ±3 °  
 DRAFT WHERE APPLICABLE  
 MUST REMAIN WITHIN DIMENSIONS

DIMENSION STYLE  
 MM ONLY

SCALE ---  
 DESIGN UNITS METRIC

THIRD ANGLE PROJECTION

TITLE  
 EMBOSSED TAPE PACKAGED  
 1.0 MM FPC CONN ZIF R/A  
 HOUSING ASSY

**molex**

DOCUMENT NO. SD-52207-070  
 SHEET NO. 3 OF 3

SIZE A3  
 THIS DRAWING CONTAINS INFORMATION THAT IS PROPRIETARY TO MOLEX  
 INCORPORATED AND SHOULD NOT BE USED WITHOUT WRITTEN PERMISSION