

THIS DRAWING IS UNPUBLISHED.

RELEASED FOR PUBLICATION

20

© COPYRIGHT 20 BY -

ALL RIGHTS RESERVED.

REVISIONS

P	LTR	DESCRIPTION	DATE	DWN	APVD
	B	INITIAL	18SEP2017	YC	CW

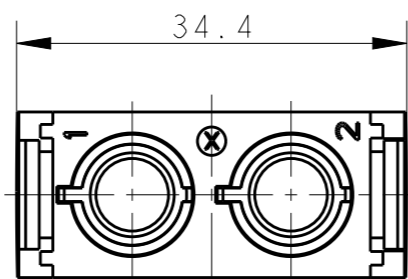
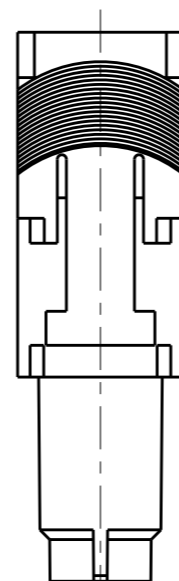
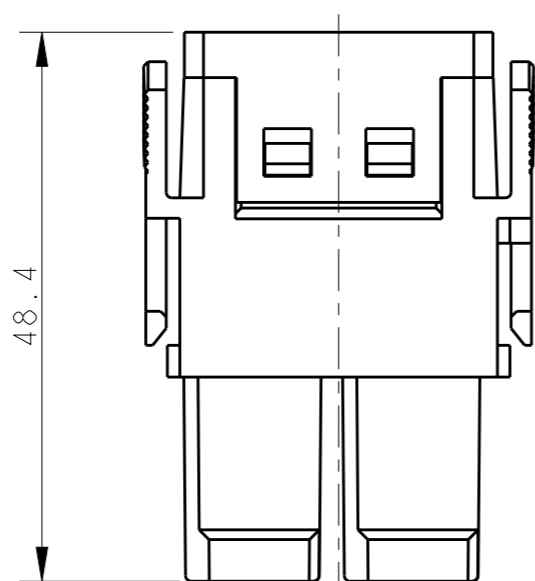
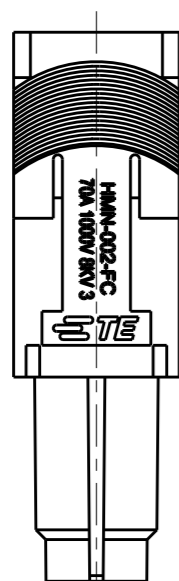
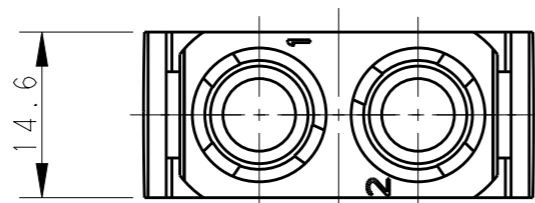
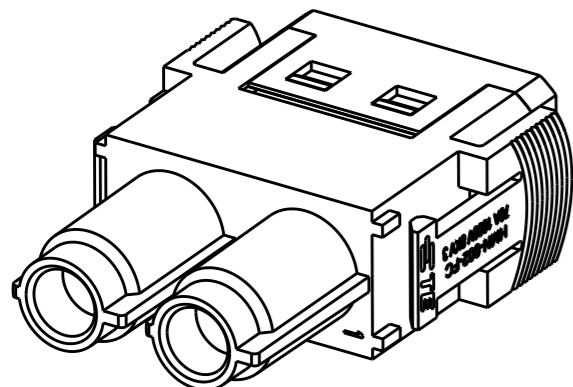

NOTES:

- TECHNICAL CHARACTERISTICS:
 INSULATION MATERIAL: PC
 RATED VOLTAGE: 1000V
 RATED CURRENT: 70A
 INSULATION RESISTANCE: $\geq 400M\Omega$
 RATED IMPULSE VOLTAGE: 8KV
 POLLUTION DEGREE: 3
 FLAMMABILITY: UL94V-0
 MATING CYCLES: 500 CYCLES
 WIRE RANGE: 10~25 mm²
 CONTACT TYPE: CRIMP CONTACT
- CONTACT NEED TO BE ORDERED SEPARATELY.
 (ORDER No. REFER TO DRAWING:T2400002XX0000)

注释:

- 技术参数:
 绝缘材料: PC
 额定电压: 1000V
 额定电流: 70A
 绝缘电阻: $\geq 400M\Omega$
 额定脉冲电压: 8KV
 污染等级: 3
 阻燃等级: UL94V-0
 插拔次数: 500次
 接线范围: 10~25 mm²
 接线类型: 冷压接
- 端子需要单独订购。
 (订货号参考图面: T2400002XX0000)

T2111020201-007	HMN-002-FC	HMN-002 FEMALE MODULE INSERT, CRIMP HMN-002 冷压模块母插
PART NUMBER 料号	PART DESCRIPTION 描述	

THIS DRAWING IS A CONTROLLED DOCUMENT.		DWN 18SEP2017 YORK CHEN		
		CHK 18SEP2017 GINO YAO		
		APVD 18SEP2017 CHRIS WANG		
		PRODUCT SPEC 108-137059		
DIMENSIONS: mm		TOLERANCES UNLESS OTHERWISE SPECIFIED:		NAME HMN-002-FC
		0 PLC ±-	1 PLC ±-	SIZE A3
		2 PLC ±-	3 PLC ±-	CAGE CODE 00779
		4 PLC ±-	ANGLES ±-	DRAWING NO T2111020201007
MATERIAL -		FINISH -		RESTRICTED TO -
		CUSTOMER DRAWING		SCALE 3:2
				SHEET 1 OF 1
				REV B