

THIS DRAWING IS UNPUBLISHED. RELEASED FOR PUBLICATION 20
 © COPYRIGHT 20 BY - ALL RIGHTS RESERVED.

REVISIONS					
P	LTR	DESCRIPTION	DATE	DWN	APVD
	A	INITIAL RELEASE	23AUG2017	YC	CW

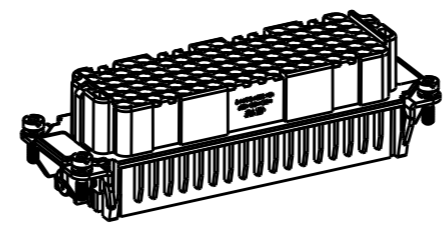
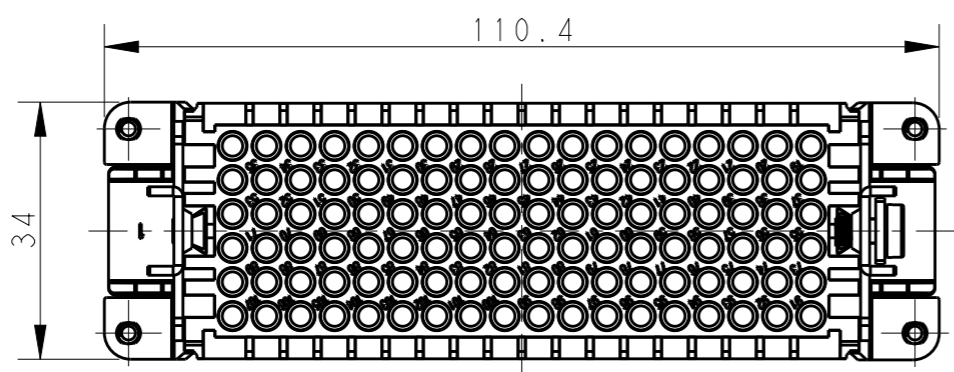

SCALE 1:2

M4 SCREW
 RECOMMENDED TIGHTENING TORQUE 1.2N.m
 M4螺丝, 推荐拧紧力矩1.2N.m
 4X M3 SCREW
 RECOMMENDED TIGHTENING TORQUE 0.5N.m
 4X M3螺丝, 推荐拧紧力矩0.5N.m

- NOTES:
- TECHNICAL CHARACTERISTICS:
 INSULATION MATERIAL: PC
 RATED VOLTAGE: 250 V
 RATED CURRENT: 10 A
 INSULATION RESISTANCE: $\geq 400M\Omega$
 RATED IMPULSE VOLTAGE: 2.5 KV
 POLLUTION DEGREE: 2
 FLAMMABILITY: UL94V-0
 MATING CYCLES: 500 CYCLES
 WIRE RANGE: 0.14-2.5 mm² (26-14 AWG)
 CONTACT TYPE: CRIMP CONTACT
 - CONTACT NEED TO BE ORDERED SEPARATELY.
 (ORDER No. REFER TO DRAWING: T20200X20XX000)

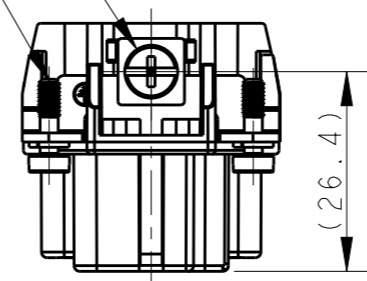
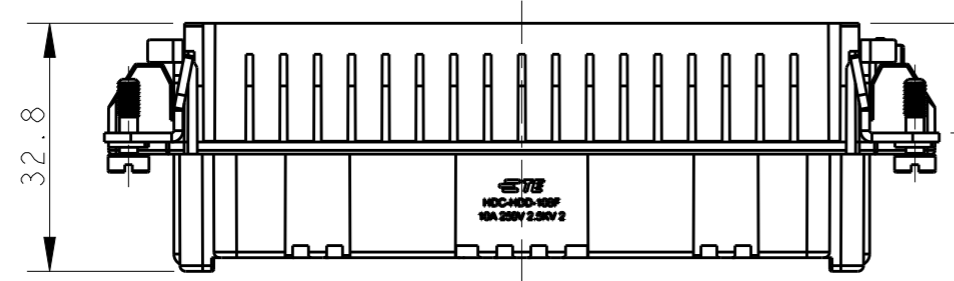
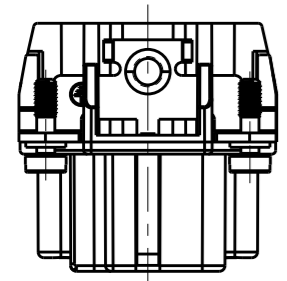

- 注释:
- 技术参数:
 绝缘材料: PC
 额定电压: 250V
 额定电流: 10A
 绝缘电阻: $\geq 400M\Omega$
 额定脉冲电压: 2.5 KV
 污染等级: 2
 阻燃等级: UL94V-0
 插拔次数: 500次
 接线范围: 0.14-2.5 mm² (26-14 AWG)
 接线类型: 冷压接
 - 端子需要单独订购.
 (订货号参考图面: T20200X20XX000)

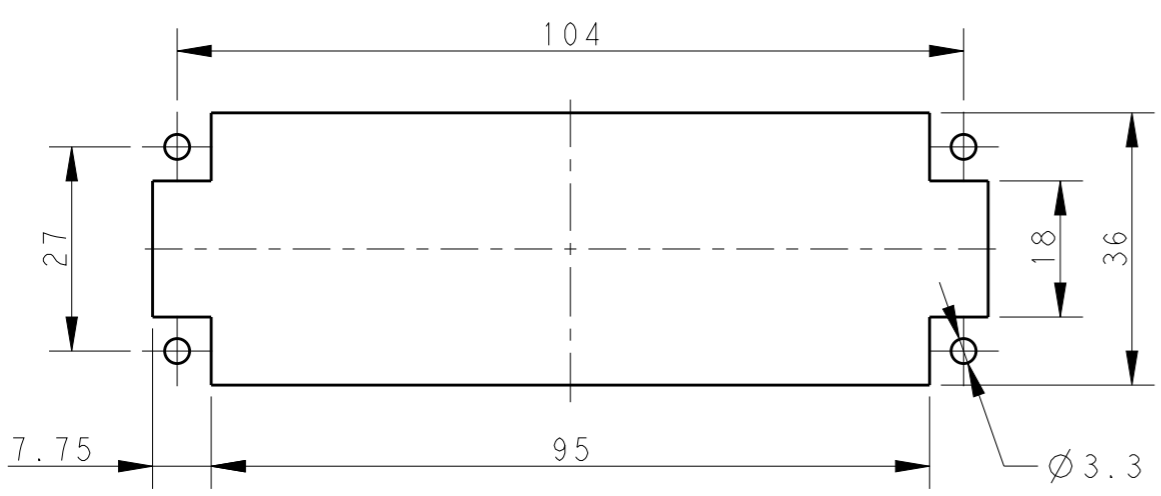
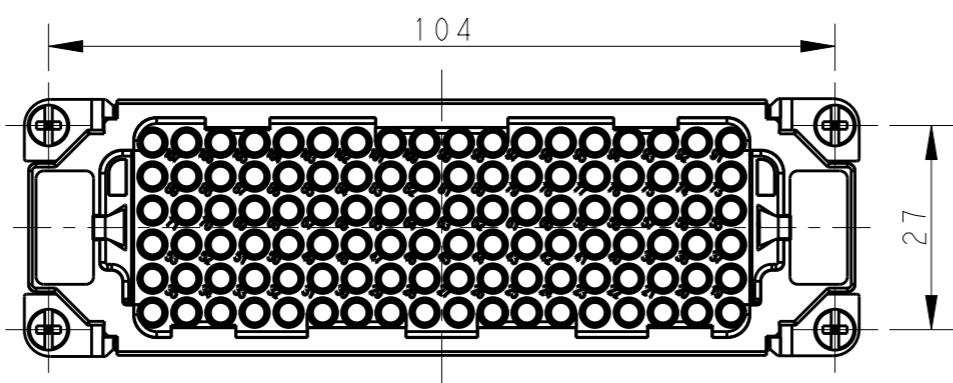

PANEL CUT OUT FOR INSERTS FOR USING WITHOUT HOODS/HOUSINGS
 不使用防护外壳时平面开孔尺寸

T2031082201-007	HDD-108-F	HDD-108 FEMALE INSERT HDD-108 母插
PART NUMBER 料号	PART DESCRIPTION 产品描述	

THIS DRAWING IS A CONTROLLED DOCUMENT.		DWN 23AUG2017 YORK CHEN	TE Connectivity	
DIMENSIONS: mm		CHK 23AUG2017 GINO YAO		
TOLERANCES UNLESS OTHERWISE SPECIFIED:		APVD 23AUG2017 CHRIS WANG	NAME HDD-108-F	
0 PLC ±-		PRODUCT SPEC 108-137043	SIZE A3	
1 PLC ±-		APPLICATION SPEC 114-137043	CAGE CODE -	DRAWING NO T2031082201007
2 PLC ±-		WEIGHT -	RESTRICTED TO -	
3 PLC ±-		CUSTOMER DRAWING	SCALE 1:1	SHEET 1 OF 1
4 PLC ±-			REV A	
ANGLES ±-				
FINISH				