

A (2:1)

contact face acc. to IEC 61076-2-109

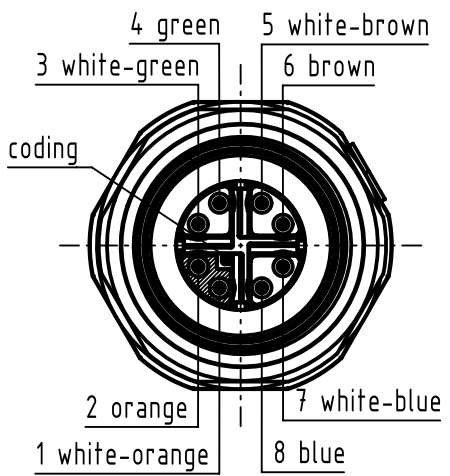

complete length when assembled app. 42 mm

width across flats: 18

width across flats: 19

width across flats: 15

panel thickness

Panel cut out (1:1)

min.2 - max.5

Ø16,3±0,2

14,3±0,2

- recommended torque of counter nut: 2Nm
- order contacts separately

cable Ø			wire gauge	part-no.
5,7 - 6,9mm	6,5 - 7,7mm	7,5 - 8,8mm		
sealing			AWG 28-24	21 01 100 9023
A	B	C	AWG 26-23	21 01 100 9021

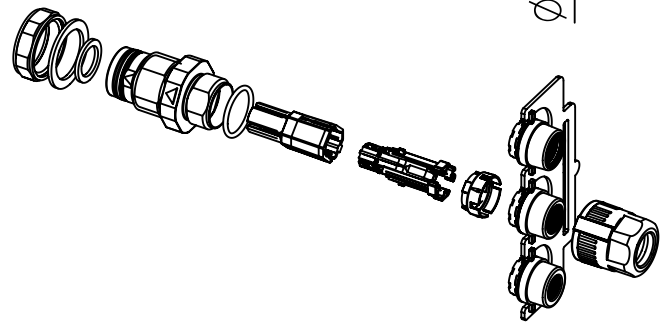

All Dimensions in mm Original Size DIN A4		Scale 1:1	Free size tol.		Ref.
All rights reserved Department EC PD - RO	Created by POPESCUD	Inspected by TAMAS	Standardisation HOFFMANN	Date 2017-10-02	State Final Release
	Title PFT Slim design female X-coded				Doc-Key / ECM-Nr. 100622656/UGD/001/H 500000124.707
HARTING Electronics GmbH D-32339 Espelkamp		Type TB	Number 21038812825		Rev. H Page 1/1