

THIS IS A C.A.D. GENERATED DRAWING
DO NOT MAKE MANUAL REVISIONS TO MASTER.

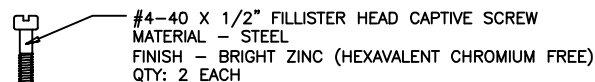

* UNLESS OTHERWISE SPECIFIED TOLERANCES
ON DECIMAL IS: ANGLE
UNIT: MM X.

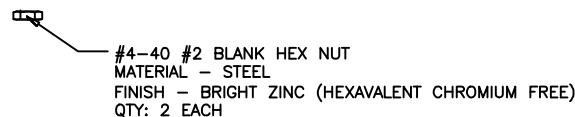
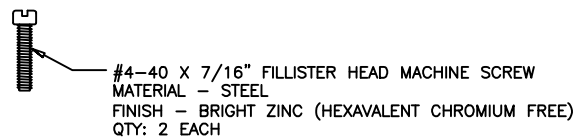
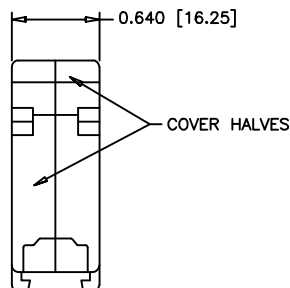
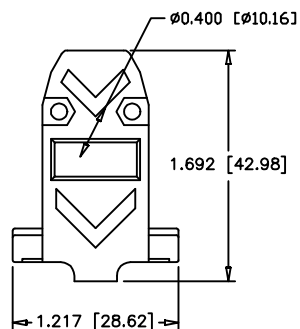
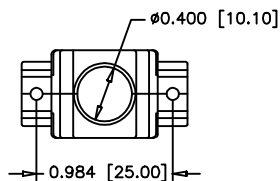

PART NUMBER INFORMATION

PART#	LOGO STYLE	SUPPLIED
A30E300000	NO LOGO	BULK
C88E300000	NO LOGO	PACKAGED

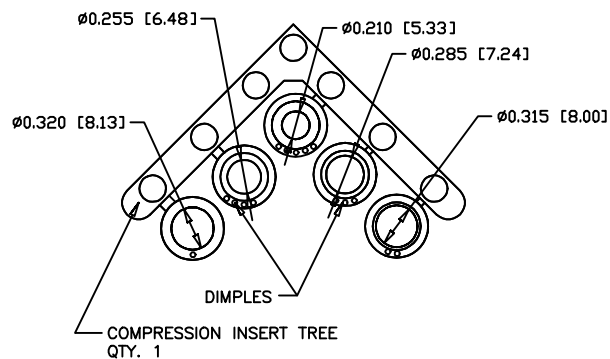

CONNECTOR COVER:

- 1.MATERIAL: ABS COMPOUND - UL94HB
- 2.FINISH: NICKEL PLATING PER NTC SPECIFICATION N/T 000500
- 3.DIMENSIONS: INCHES [MM]
- 4.TOLERANCE: ±0.015 [0.381]

COMPRESSION INSERT TREE

- 1.MATERIAL: THERMOPLASTIC
- 2.COLOR: BLACK
- 3.DUROMETER: 75 ±5 TYPE A PER ASTM D2240
- 4.DIMENSIONS: INCHES [MM]
- 5.TOLERANCE: ±0.020 [0.508]

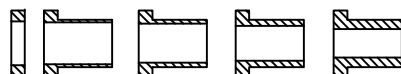

THESE DRAWINGS AND SPECIFICATIONS ARE THE PROPERTY OF MH CONNECTORS AND SHALL NOT BE REPRODUCED, COPIED OR USED AS THE BASIS FOR THE MANUFACTURE OR SALE OF APPARATUS WITHOUT WRITTEN PERMISSION.	DRAWN Arthur Zheng	DATE 01-12-18
	APPROVED Victor Lin	DATE 01-12-18
MH CONNECTORS , DIVISION OF EDAC	SCALE 1 : 1	SHEET OF 1 OF 1
	REV: 1.0	
DRAWING No C88E300000		



THIS SERIES FULLY CONFORMS TO THE EUROPEAN UNION DIRECTIVES 2002/95/EC AND 2002/96/EC FOR RoHS COMPLIANCY.

