

THIS DRAWING IS UNPUBLISHED. RELEASED FOR PUBLICATION APRIL, 2004.

© COPYRIGHT 2004 BY TYCO ELECTRONICS CORPORATION. ALL RIGHTS RESERVED.

LOC	DIST	REVISIONS					
E	B	P	LTR	DESCRIPTION	DATE	DWN	APVD
		A		EBD0-0035-03	28JAN04	RS	FWK

NOTES:

- ① SINGLE PACK IN ACCORDANCE WITH SPEC 107-3275
- ② 100 TRAY PACK IN ACCORDANCE WITH SPEC 107-3275
- ③ 0.08µm Au PLATING OVER 1.27µm Ni PLATING
- ④ 0.08µm Au PLATING OVER 1.27µm Ni PLATING OVER 0.76µm Cu PLATING
- ⑤ 0.76µm Au PLATING OVER 1.27µm Ni PLATING OVER 0.76µm Cu PLATING
- ⑥ PASSIVATED (GOLD PLATED CABLE ENTRY)
- 7 FOR TECHNICAL DATA REFER TO YOUR LOCAL TYCO ELECTRONICS SALES OFFICE
- 8 ALL DIMENSIONS ARE NOMINAL FOR REFERENCE ONLY UNLESS OTHERWISE STATED

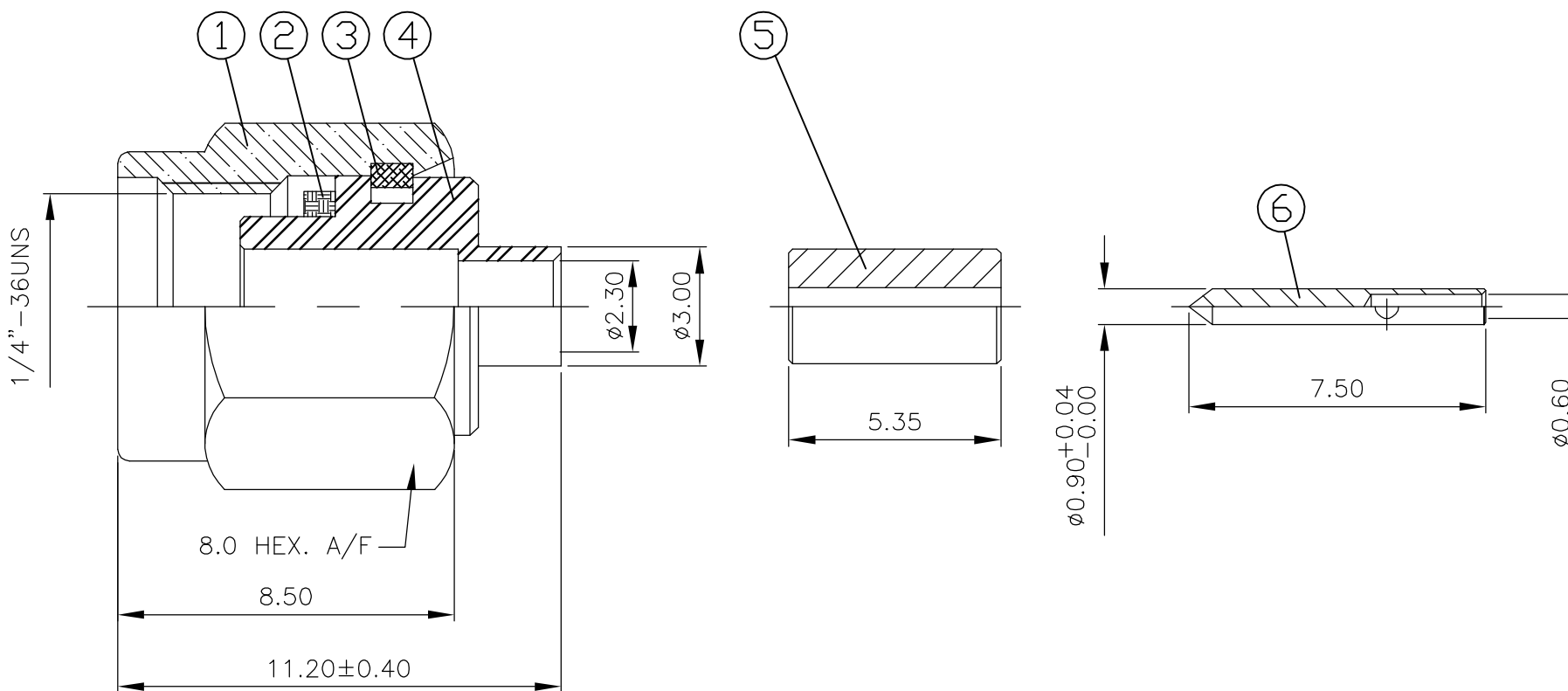

RECOMMENDED CABLE STRIPPING DIM'S

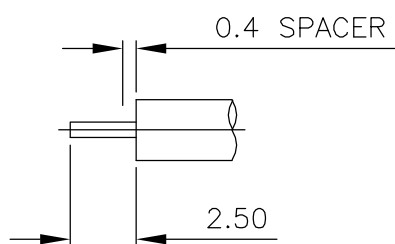

		1	1	1	1	1	1	BRASS	⑤	CENTER CONTACT	6
		1	1	1	1	1	1	PTFE		INSULATOR	5
		1	1	-	-	-	-	BRASS	④	BODY	4
		-	-	1	1	-	-	STAINLESS STEEL	⑥	BODY	4
		-	-	-	-	1	1	STAINLESS STEEL	③	BODY	4
		1	1	1	1	1	1	STAINLESS STEEL		CIRCLIP	3
		1	1	1	1	1	1	SILICON		GASKET	2
		1	1	-	-	-	-	BRASS	④	SHELL	1
		-	-	1	1	-	-	STAINLESS STEEL	⑥	SHELL	1
		-	-	-	-	1	1	STAINLESS STEEL	③	SHELL	1
		3--1	3--0	2--1	2--0	1--1	1--0	MATERIAL		DESCRIPTION	ITEM
		②	①	②	①	②	①				
QUANTITY PER ASSY						PARTS LIST					

THIS DRAWING IS A CONTROLLED DOCUMENT.		DWN R.SMITH 28JAN04	Tyco Electronics Corporation Bideford, UK, EX39 4HE	
DIMENSIONS: mm		CHK S.PARLOW 28JAN04		
TOLERANCES UNLESS OTHERWISE SPECIFIED:		APVD F.WHEELER-KING 28JAN04	NAME SMA STRAIGHT PLUG DIRECT SOLDER NON CAPTIVE CENTRE CONTACT RG405/U	
0 PLC ± - 1 PLC ± - 2 PLC ± - 3 PLC ± - 4 PLC ± - ANGLES ± - FINISH -		PRODUCT SPEC 108-3460	RESTRICTED TO	
MATERIAL SEE TABLE		APPLICATION SPEC 411-3276	SIZE A3	CAGE CODE 00779
		WEIGHT -	DRAWING NO C-1478904	REV A
CUSTOMER DRAWING			SCALE 1:1	SHEET 1 OF 1