

LOC	DIST	REVISIONS			
P	LTN	DESCRIPTION	DATE	DMN	APVD
GP	00				
A1		REVISED 2299924-6 HS HEIGHT	20NOV2017	TX	SH
B		REVISED PER ECO-18-006791	07MAY2018	TX	SH
C		REVISED PER ECO-18-011602	24JUL2018	TX	SH

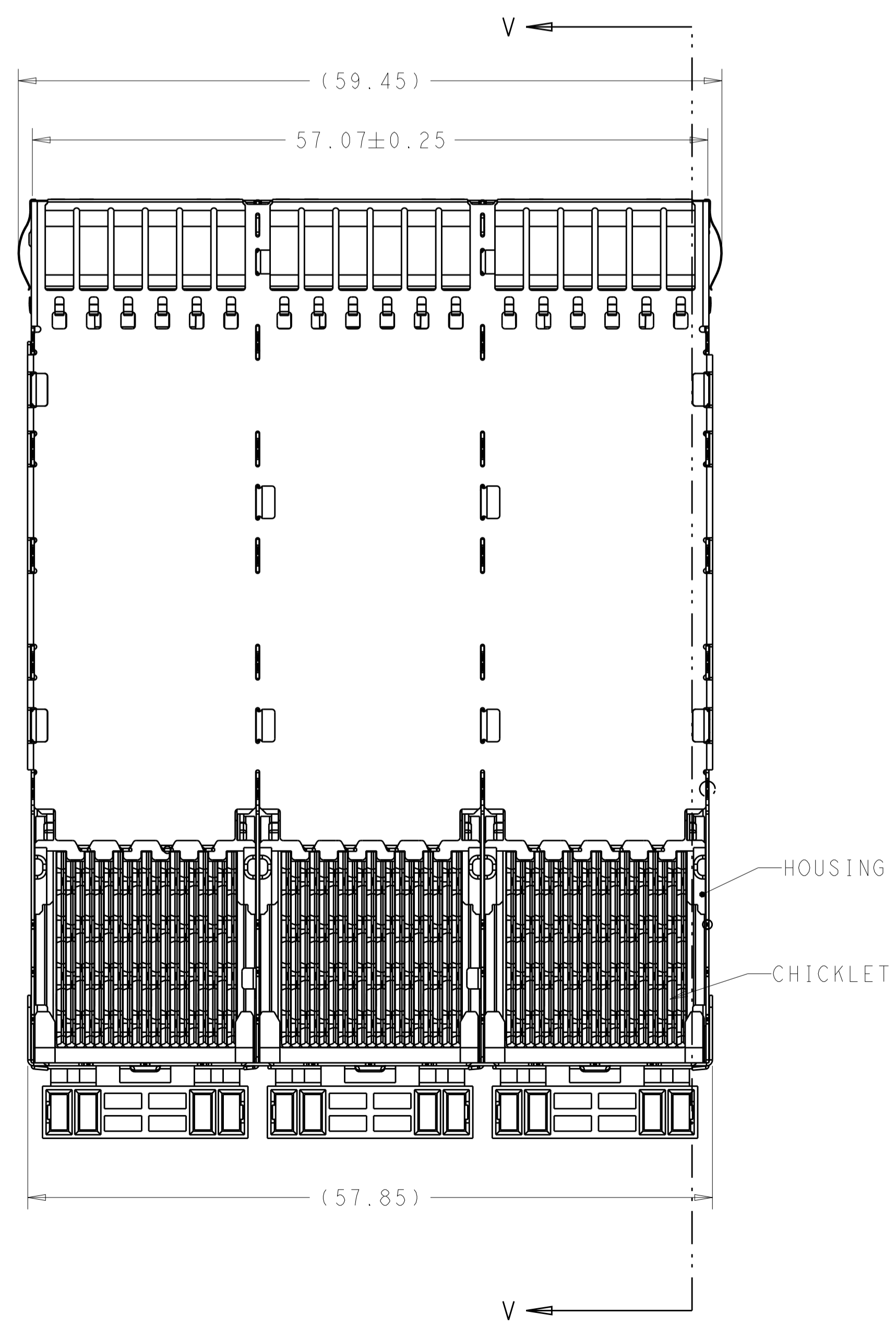
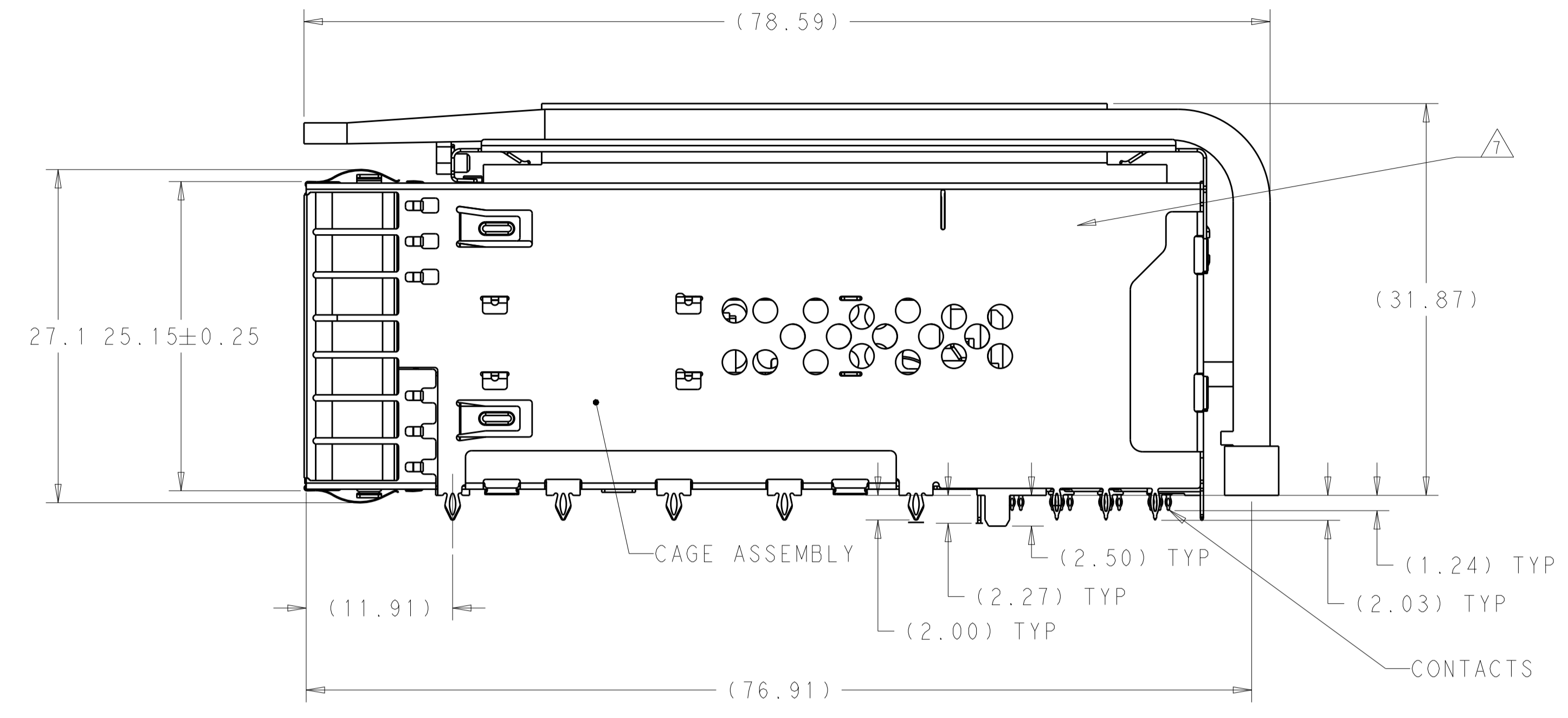
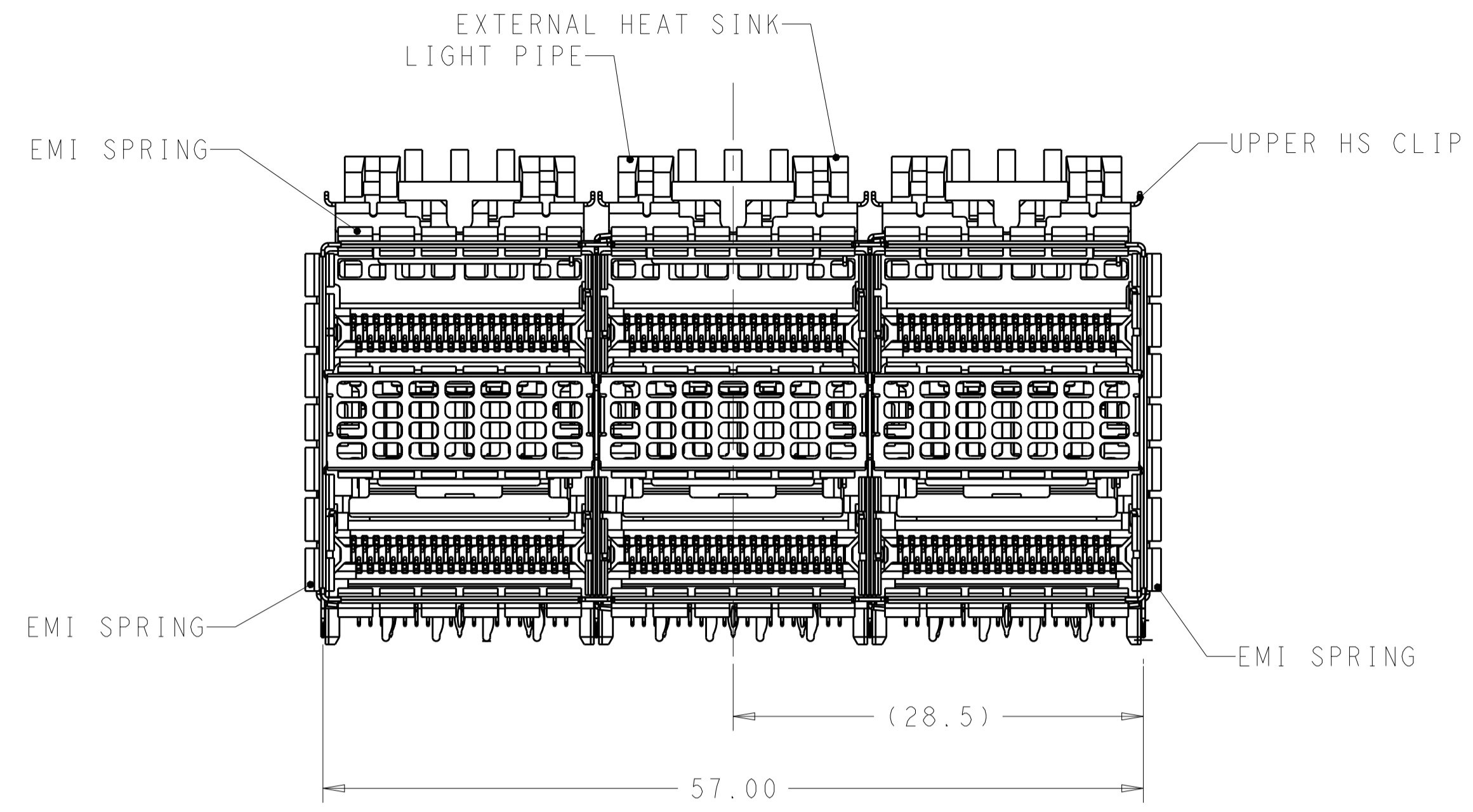

- MATERIALS:
 CAGE ASSEMBLY- NICKEL SILVER ALLOY PER ASTM B 122.
 EMI SPRING- COPPER ALLOY, NICKEL PLATED.
 HOUSING- POLYESTER LCP WITH 94 V-0
 CHICKLET- POLYESTER LCP WITH 94 V-0
 CONTACT- COPPER ALLOY.
 LIGHTPIPE- POLYCARBONATE
 HEAT SINK- ALUMINUM
 CLIP- STAINLESS STEEL
- CONTACT FINISH: 0.76µm GOLD ON MATING AREA, 0.7-1.5µm MATT TIN ON COMPLIANT AREA, ALL OVER 1.27µm NICKEL.
- DATUM AND BASIC DIMENSION ESTABLISHED BY CUSTOMER.
- MINIMUM PCB THICKNESS OF 1.57.
- THE ENTIRE AREA OF THE CONNECTOR FOOTPRINT, INDICATED BY THE DASHED LINE, TO BE CONSIDERED THE KEEPOUT AREA FOR COMPONENTS.
- CROSS-HATCHED AREAS REPRESENT ZONES ON THE PCB THAT COME IN CONTACT WITH OR BE IN CLOSE PROXIMITY TO THE PLASTIC HOUSING OR THE CONNECTOR CAGE. INDICATED AREAS TO BE CONSIDERED TRACE FREE.
- PART NUMBER AND DATE CODE MADE IN APPROXIMATE AREA SHOWN.
- HATCHED AREA IS PLACEMENT ZONE FOR LED. LED SHOULD BE CENTERED WITHIN ZONE. RECOMMEND 0805 PACKAGE

CONTACT FINISH	DESCRIPTION	PART NUMBER
2	WITH HS & WITH LP	1-2299924-6
2	WITH HS & WITH LP	1-2299924-1
2	WITH HS & WITH LP	1-2299924-0
2	WITH HS & WITH LP	2299924-7
2	WITH HS & WITH LP	2299924-6
2	WITH HS & WITH LP	2299924-5
2	WITHOUT UPPER HS OR LP	2299924-4
2	WITH HS & WITHOUT LP	2299924-3
2	WITH HS & WITHOUT LP	2299924-2
2	WITH HS & WITH LP	2299924-1

THIS DRAWING IS A CONTROLLED DOCUMENT. DWG: ARTHUR_JLW 20JAN2016
 CHK: SEAN_HAN 20JAN2016
 APVD: SEAN_HAN 20JAN2016

DIMENSIONS: mm
 TOLERANCES UNLESS OTHERWISE SPECIFIED:
 0 PLC ±
 1 PLC ±0.25
 2 PLC ±0.15
 3 PLC ±
 4 PLC ±
 ANGLES ±

MATERIAL: SEE NOTE 1
 FINISH: SEE NOTE 2

WEIGHT: -
 CUSTOMER DRAWING

SCALE: 1:1
 SHEET: 1 OF 8
 REV: C

STE TE Connectivity
 NAME: CAGE AND CONNECTOR ASSEMBLY WITH EMI SPRING FINGERS, THRU BEZEL, 2X3 ZOSFP+ STACKED WITH HS
 SIZE: A1
 CAGE CODE: 00779
 DRAWING NO: C=2299924

LOC	DIST	REVISIONS			
P	LYR	DESCRIPTION	DATE	OWN	APVD
GP	00	SEE SHEET 1			

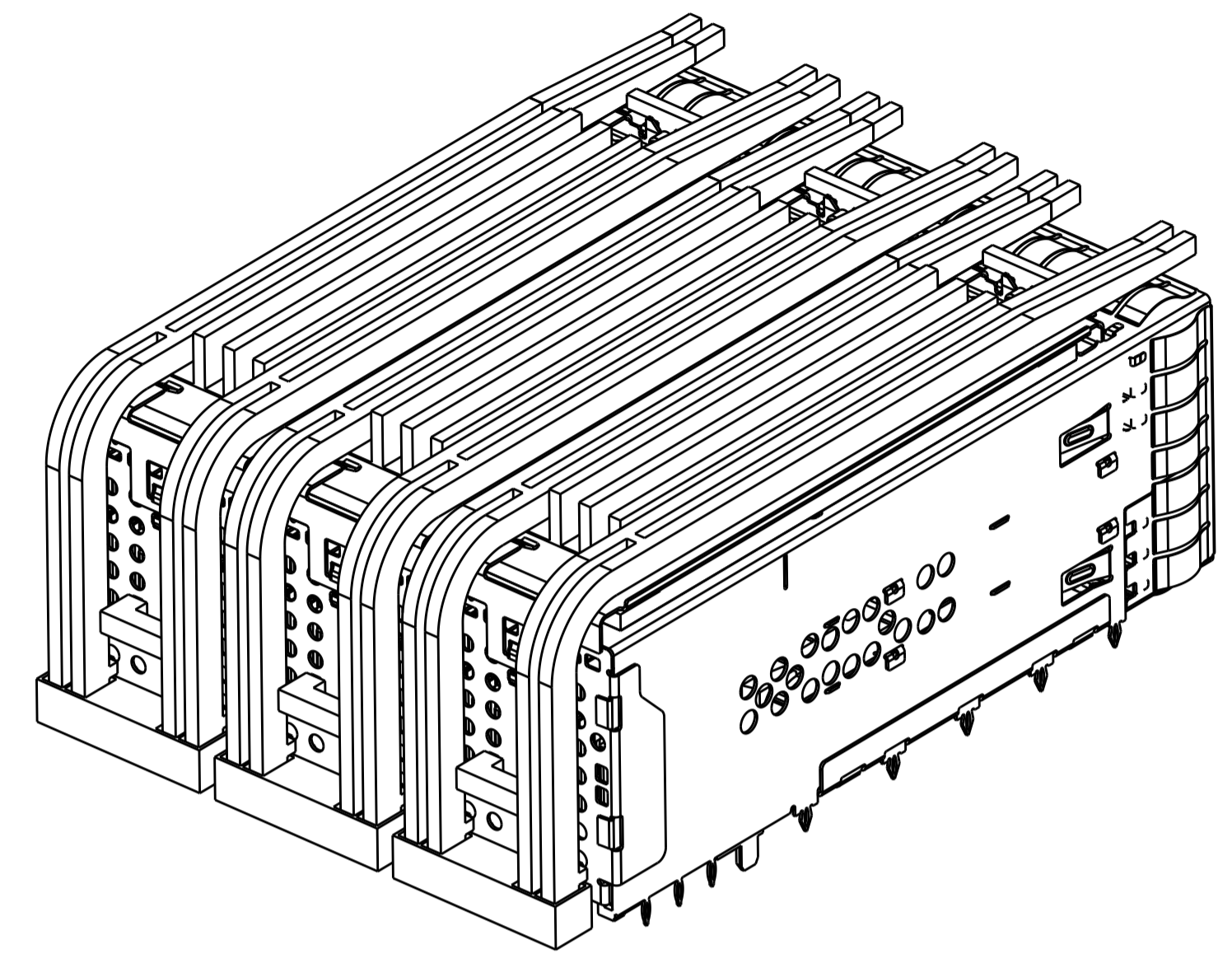

2299924-1
 1-2299924-1
 AS SHOWN
 SCALE 2:1

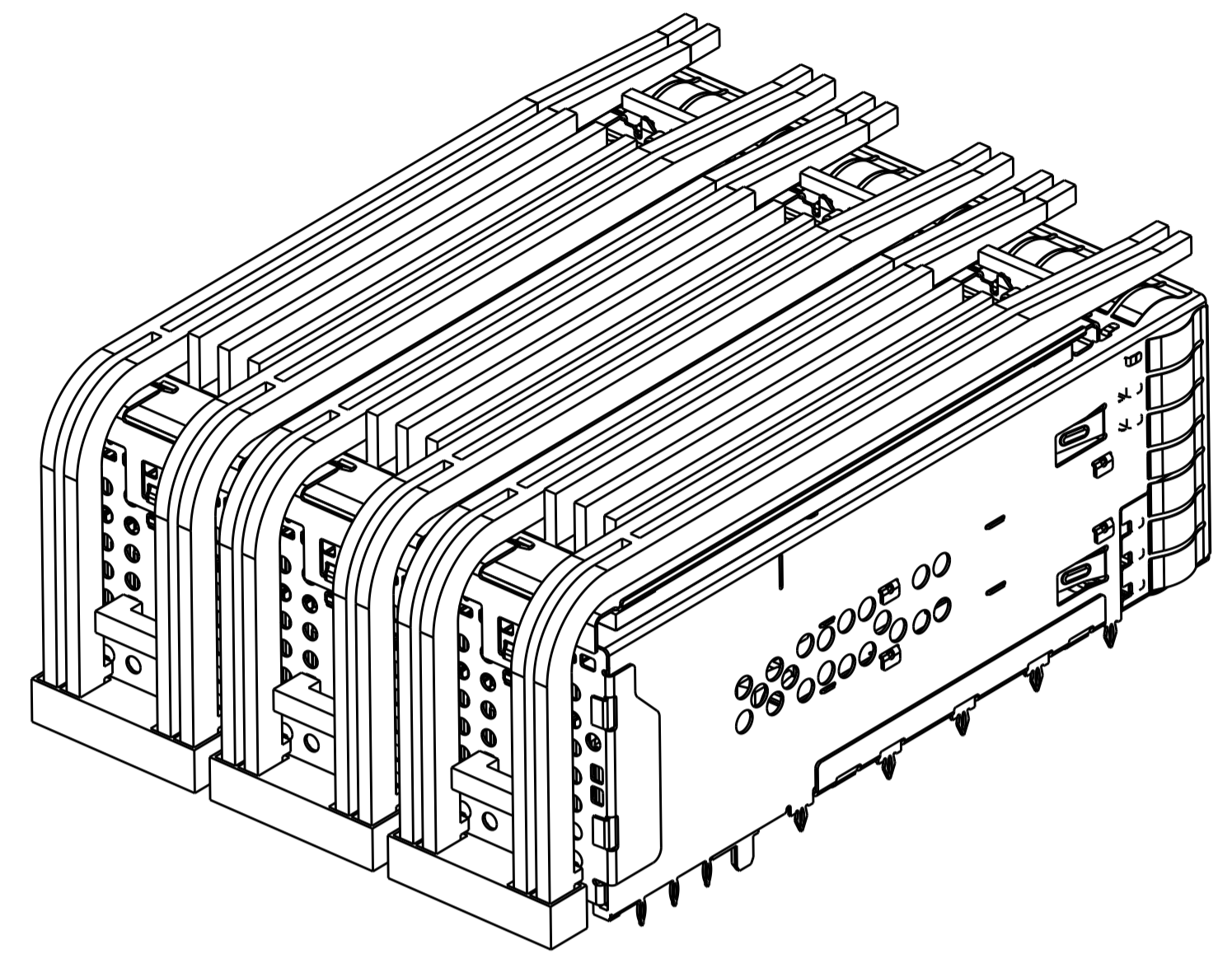

2299924-5 AS SHOWN
 HAS THE SAME APPEARANCE WITH 2299924-1
 BUT DIFFERENT INTERNAL HEAT SINK
 SCALE 2:1

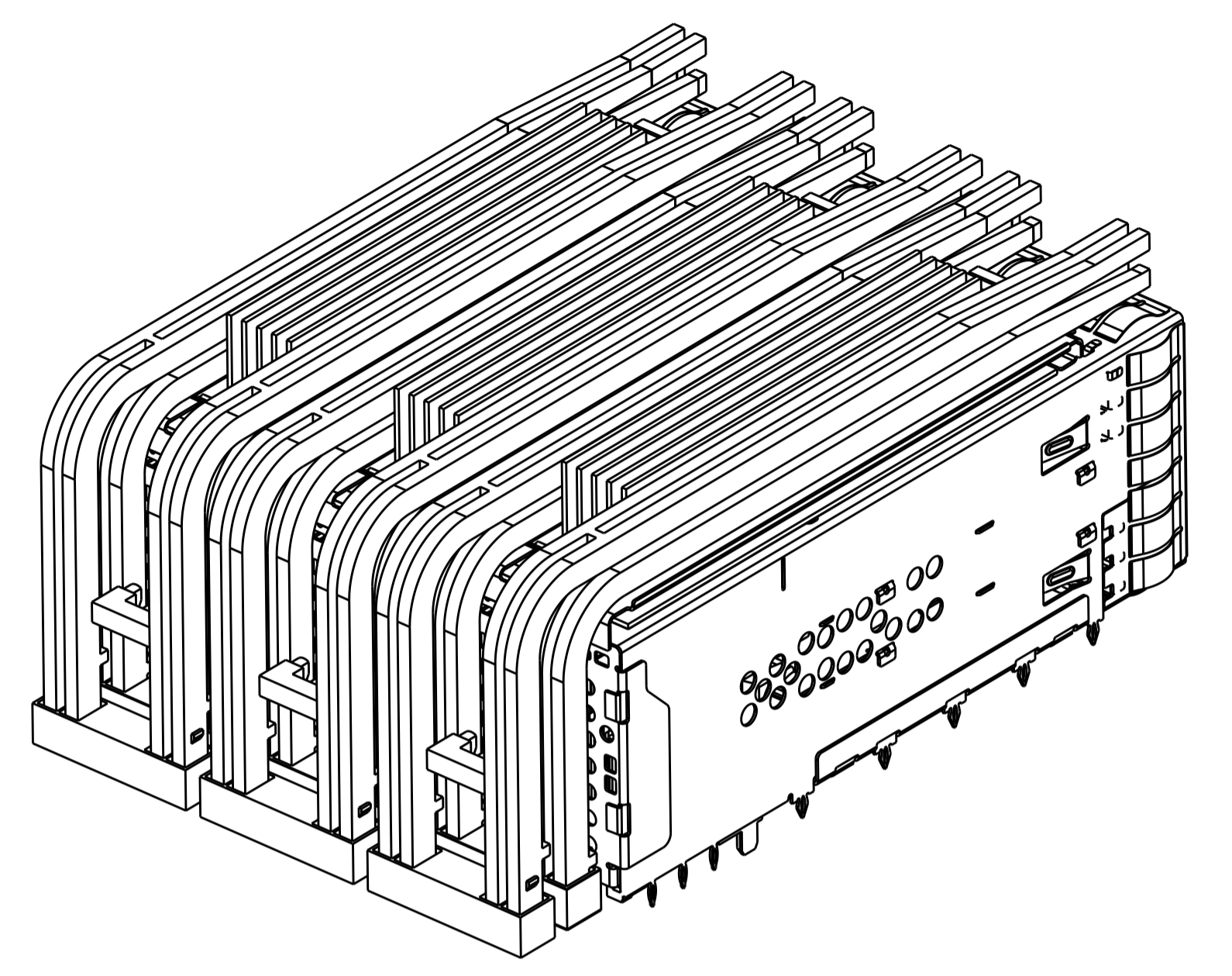

2299924-7
 SCALE 2:1

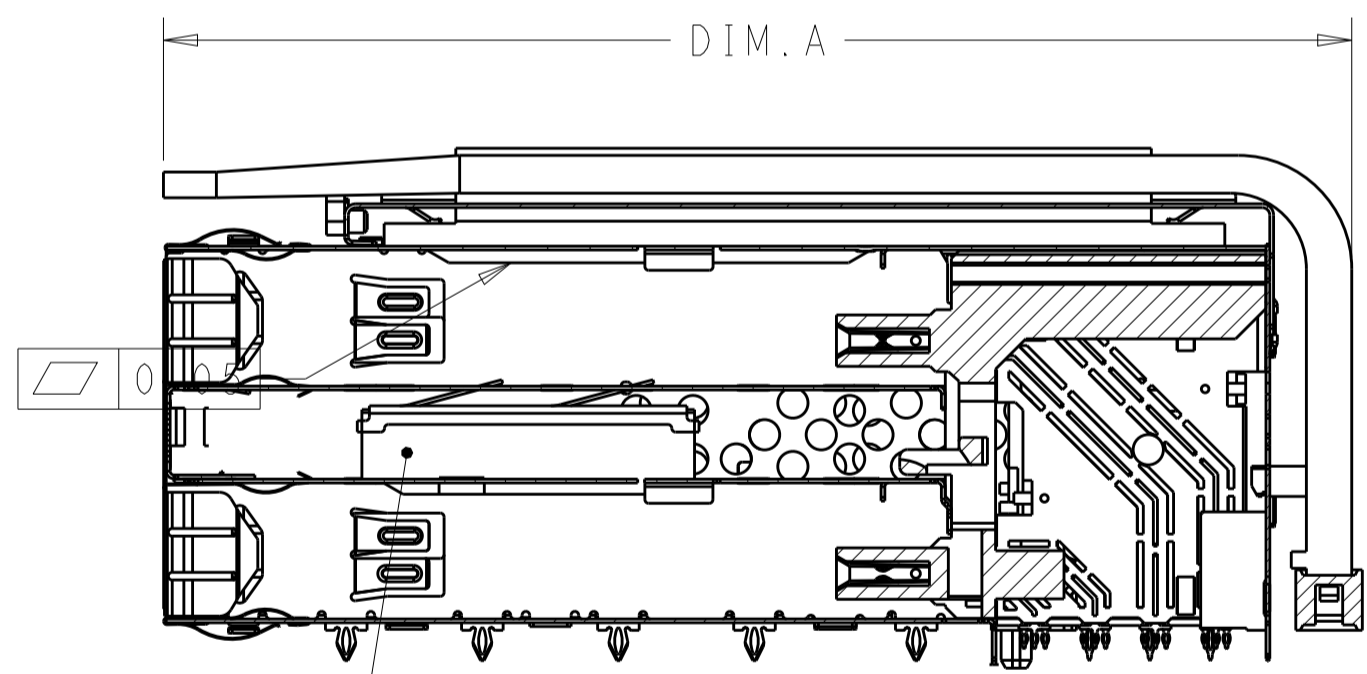

SHORT INTERNAL
 HEAT SINK

2299924-1
 1-2299924-1
 SECTION VIEW
 SECTION V-V
 SCALE 2:1

75.3	1-2299924-1
78.59	2299924-1
DIM.A	PART NUMBER

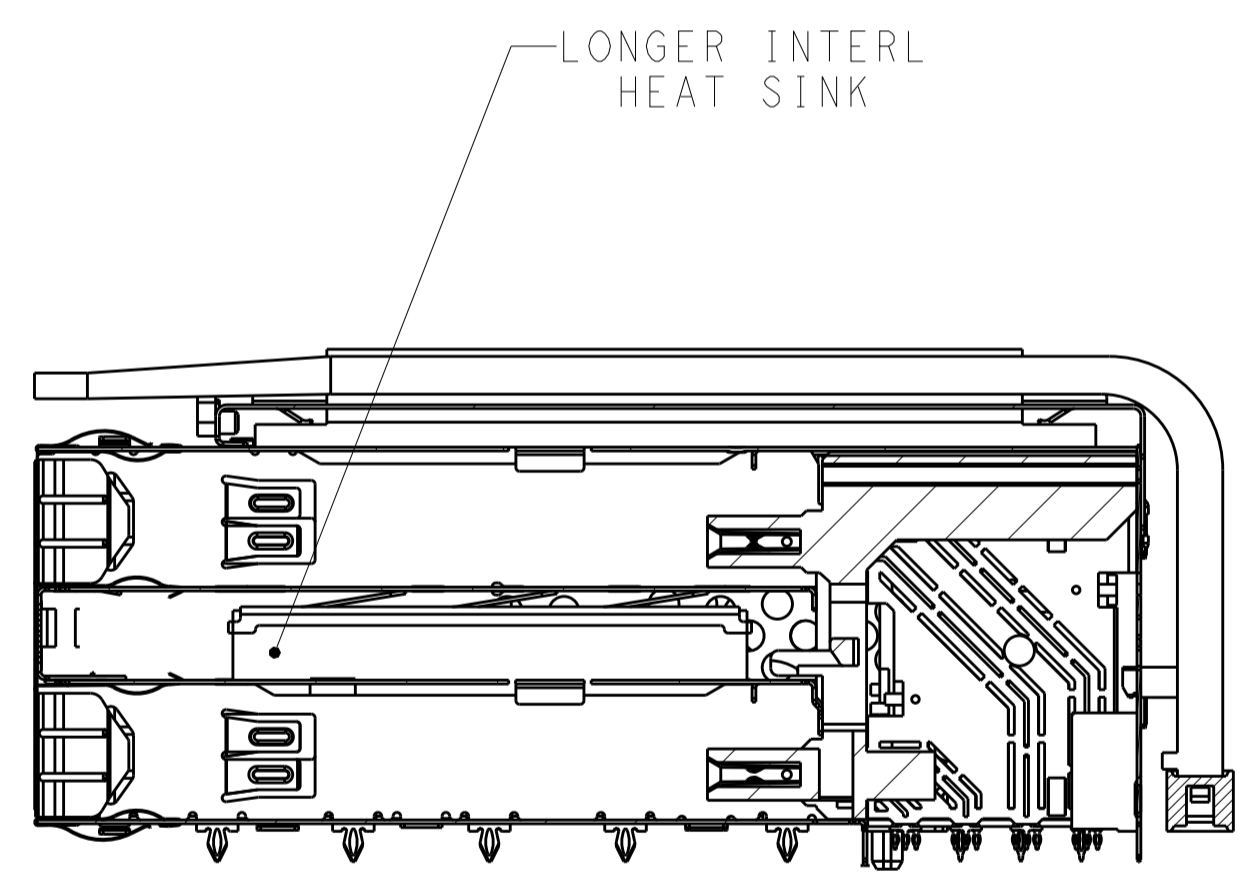

2299924-5 SECTION VIEW
 THE SAME AS 2299924-1 EXCEPT THE LONGER INTER HEAT SINK
 SECTION V-V
 SCALE 2:1

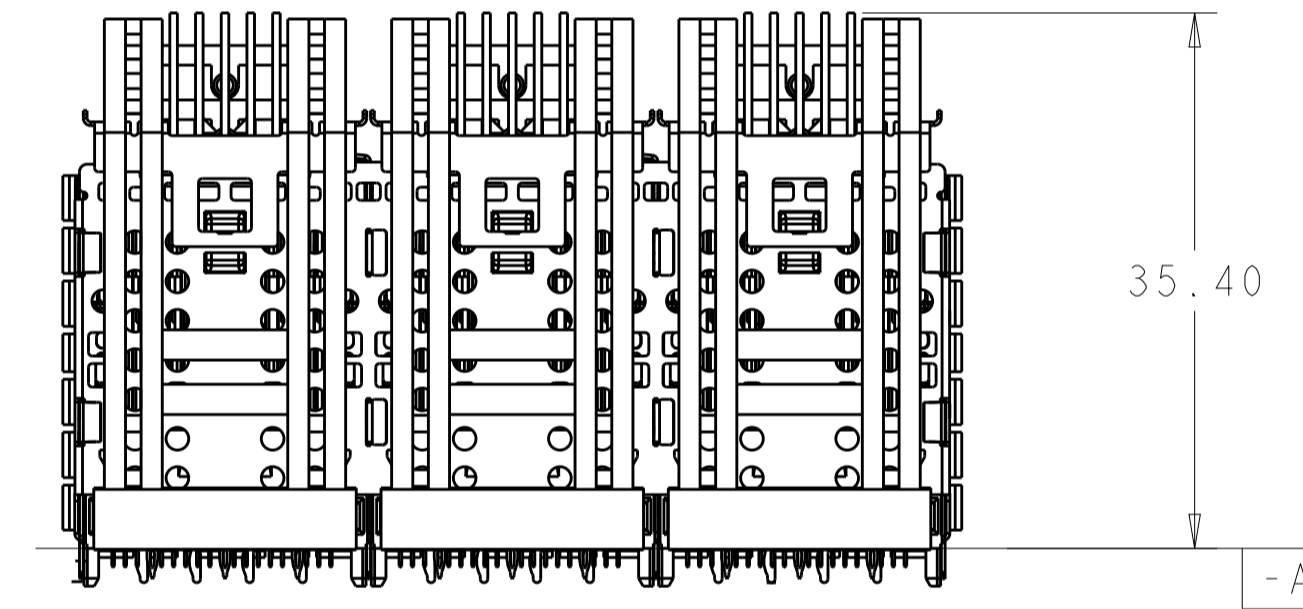

2299924-7
 SCALE 2:1

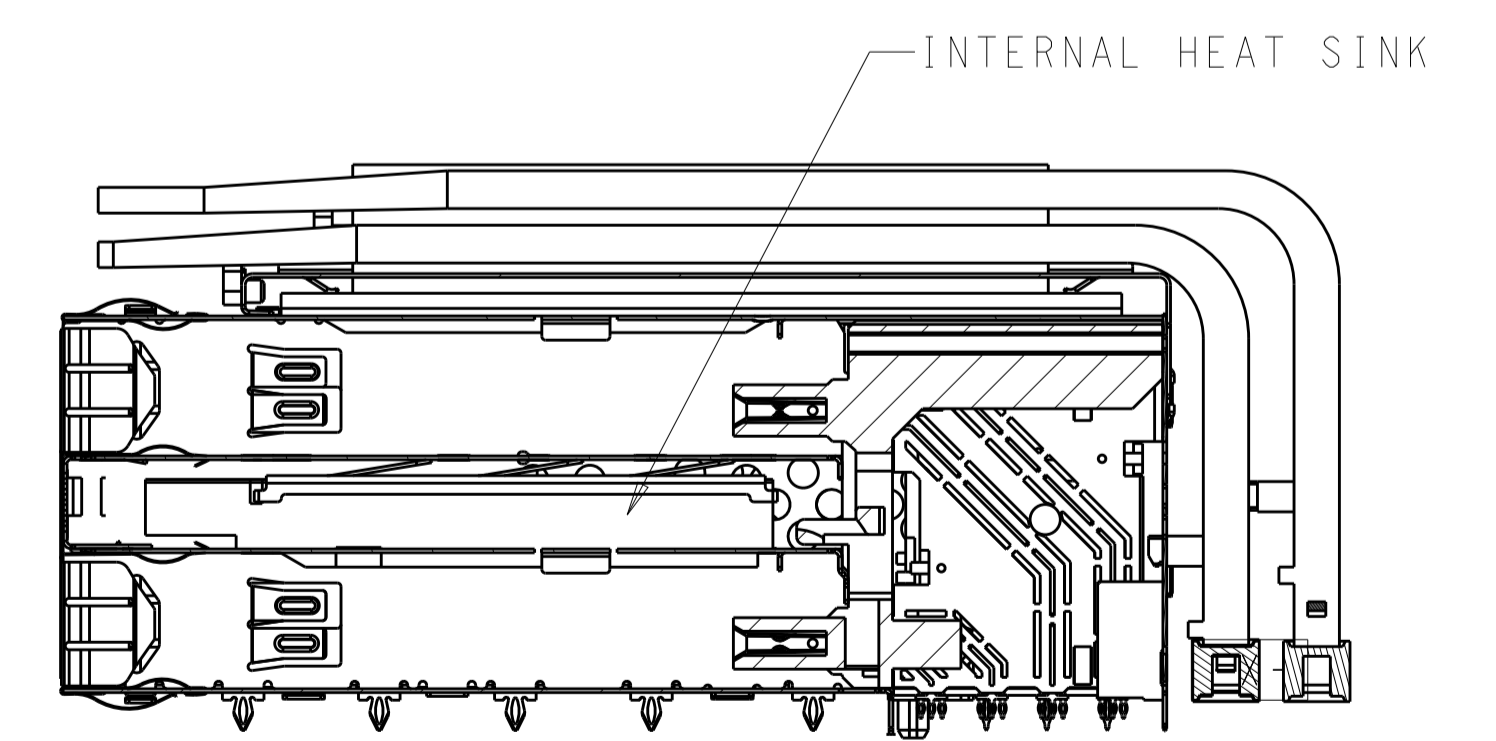

2299924-7
 SECTION V-V
 SCALE 2:1

THIS DRAWING IS A CONTROLLED DOCUMENT.		OWN: ARTHUR JIN 20JAN2016	TE Connectivity
DIMENSIONS:		CHK: SEAN HAN 20JAN2016	
mm	0 PLC ±	APVD: SEAN HAN 20JAN2016	NAME: CAGE AND CONNECTOR ASSEMBLY WITH EMI SPRING FINGERS, THRU BEZEL, 2X3 ZOSFP+ STACKED WITH HS
	1 PLC ±0.25	PRODUCT SPEC	
	2 PLC ±0.15	APPLICATION SPEC	SIZE: CAGE CODE DRAWING NO. RESTRICTED TO
	3 PLC ±	WEIGHT	A100779C=2299924
	4 PLC ±	CUSTOMER DRAWING	SCALE 1:1 SHEET 2 OF 8 REV C
	ANGLES ±		
MATERIAL	FINISH		
SEE NOTE 1	SEE NOTE 2		

LOC	DIST	REVISIONS					
GP	00	P	LYR	DESCRIPTION	DATE	OWN	APVD
				SEE SHEET 1			

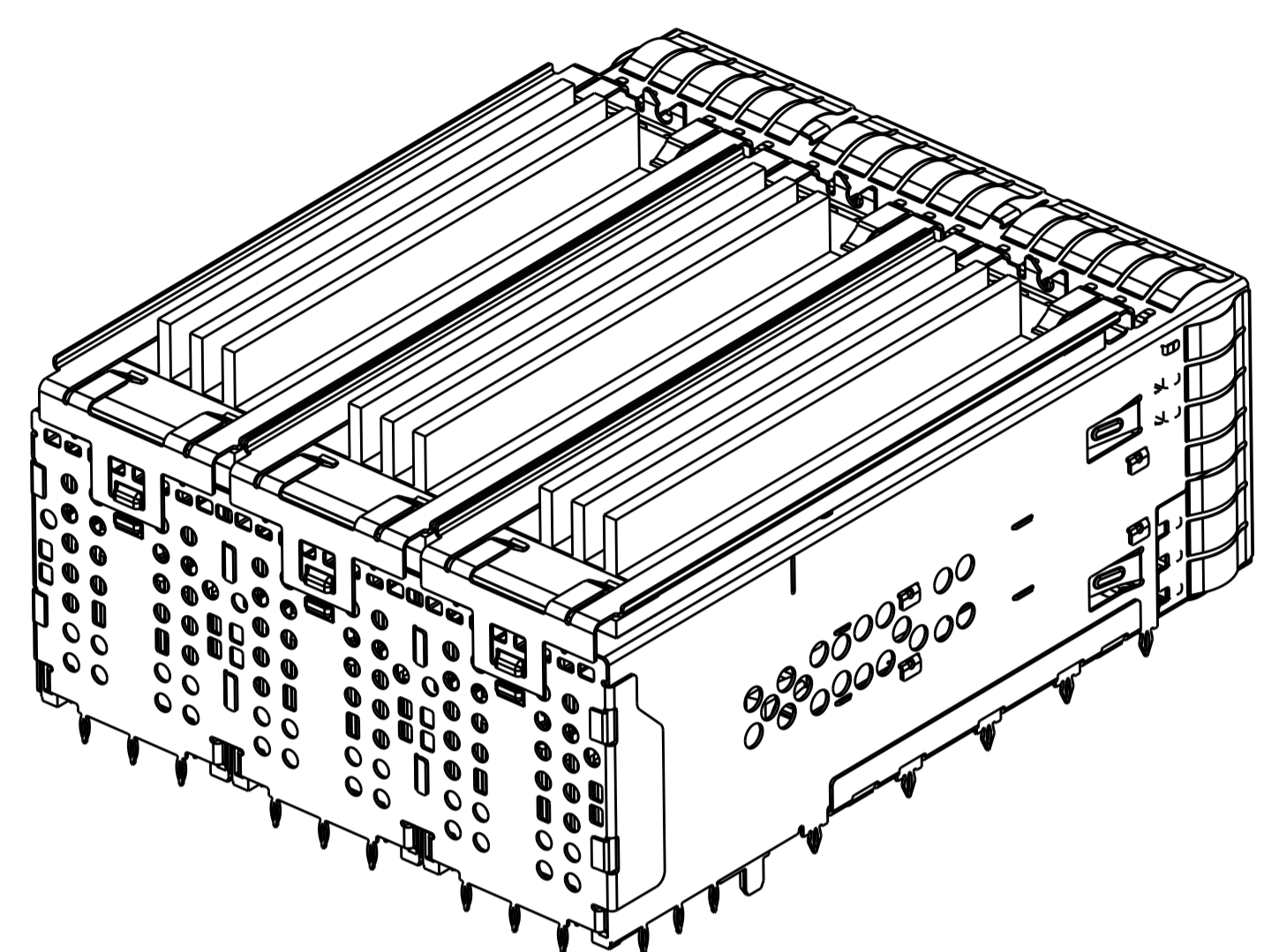

2299924-2 AS SHOWN
 THE SAME AS 2299924-5 EXCEPT
 W/O LIGHT PIPE AND ORGANIZER
 SCALE 2:1

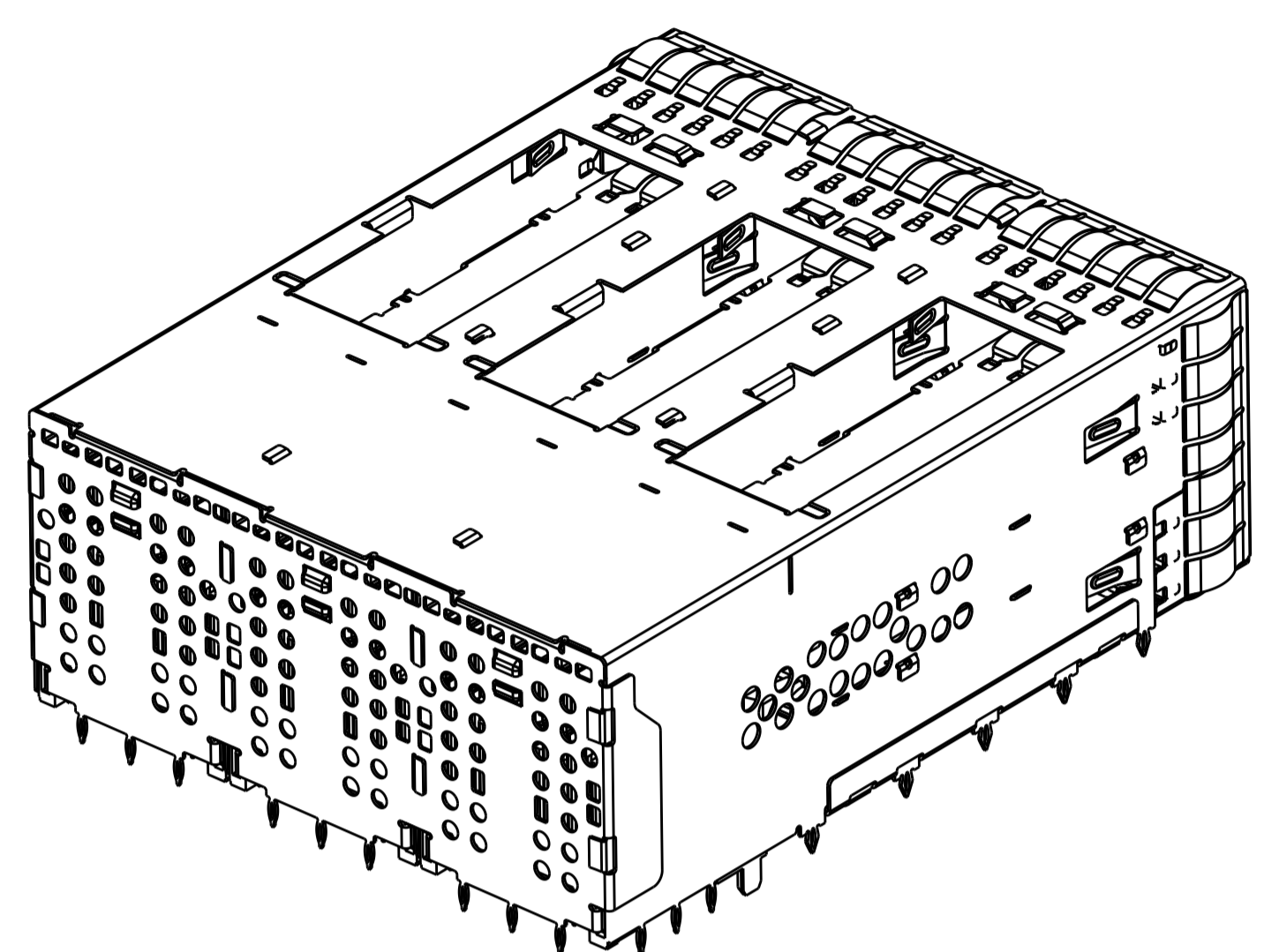

2299924-4 AS SHOWN
 THE SAME AS 2299924-2 EXCEPT
 WITHOUT EXTERNAL HEAT SINK AND LP
 SCALE 2:1

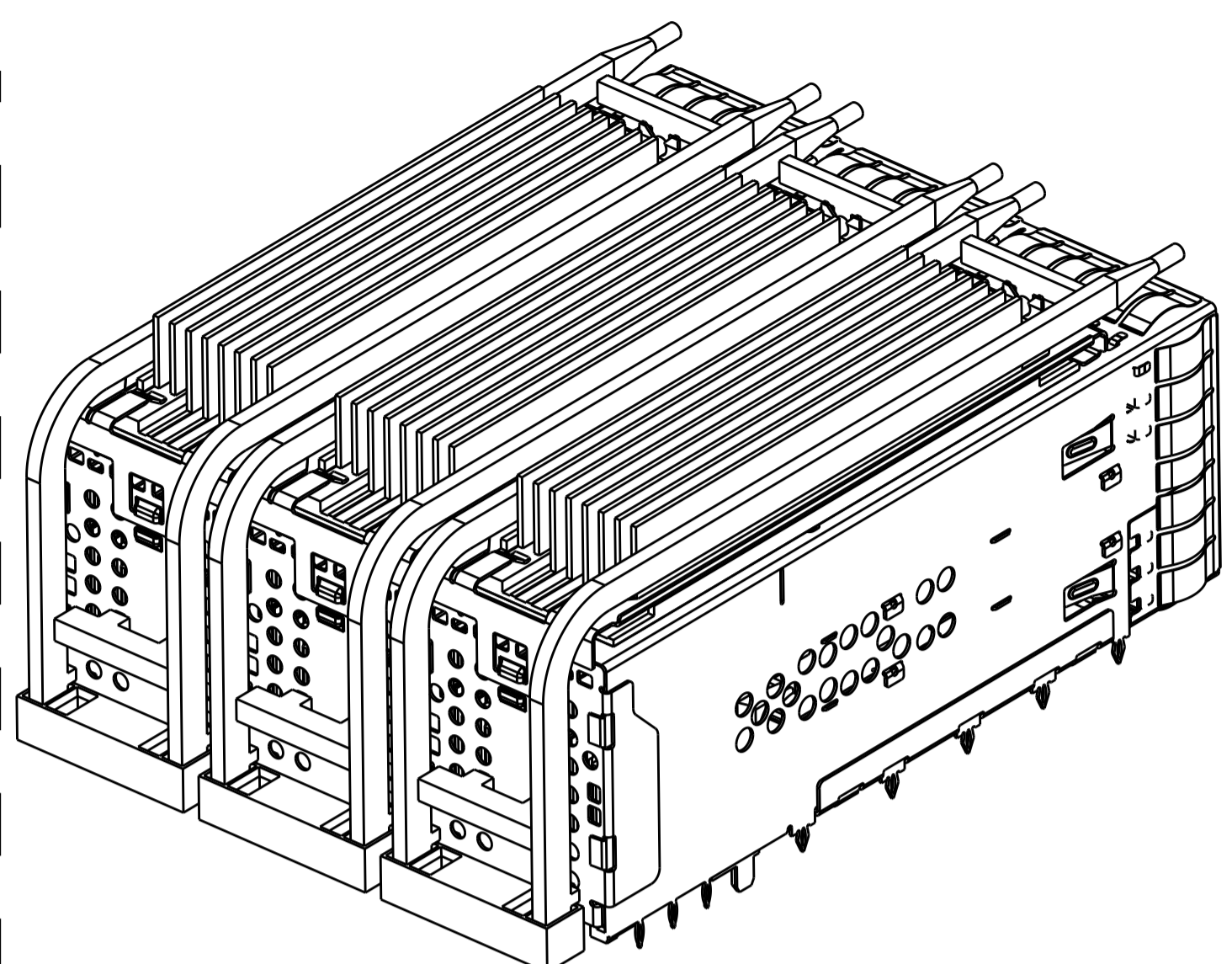

2299924-6
 SCALE 2:1

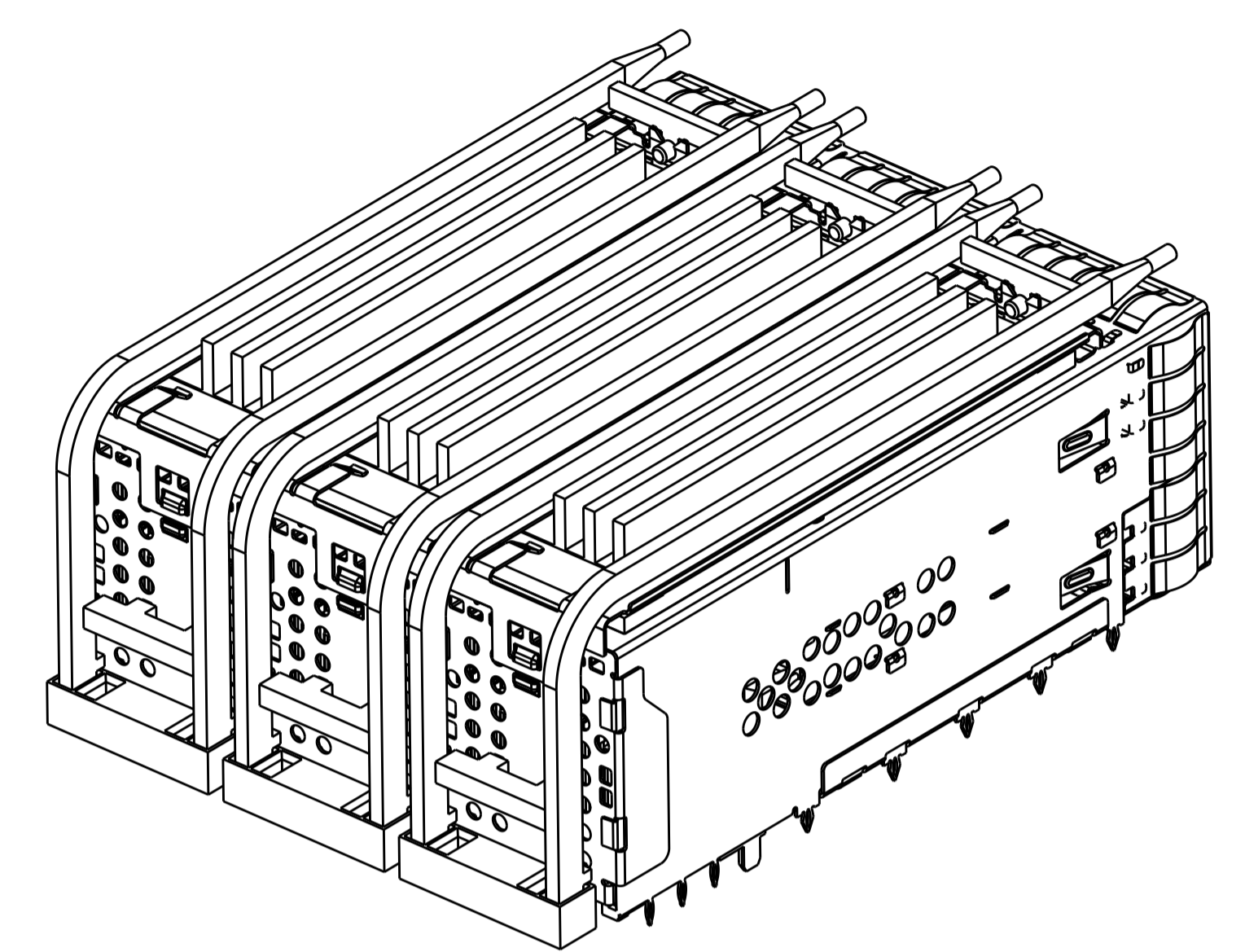

1-2299924-0
 SCALE 2:1

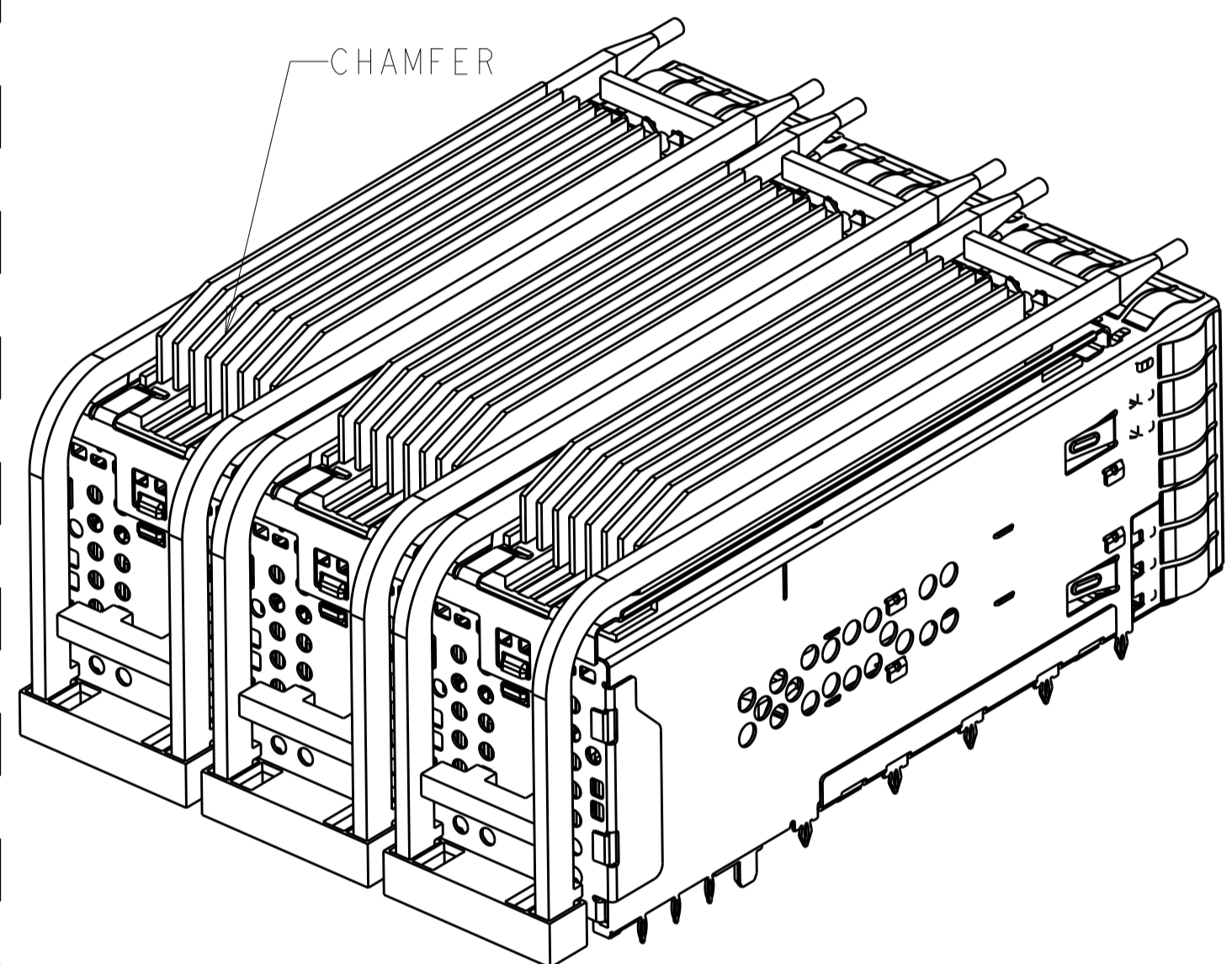

1-2299924-6
 SCALE 2:1

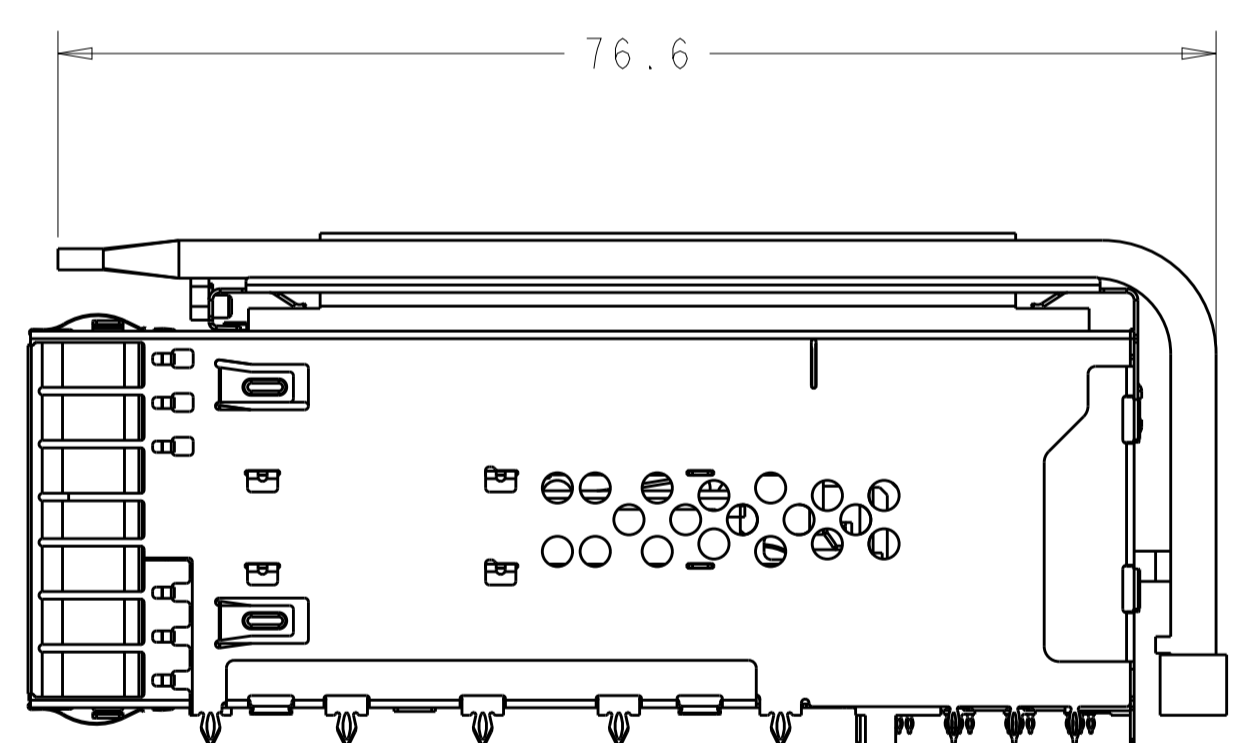

SCALE 2:1

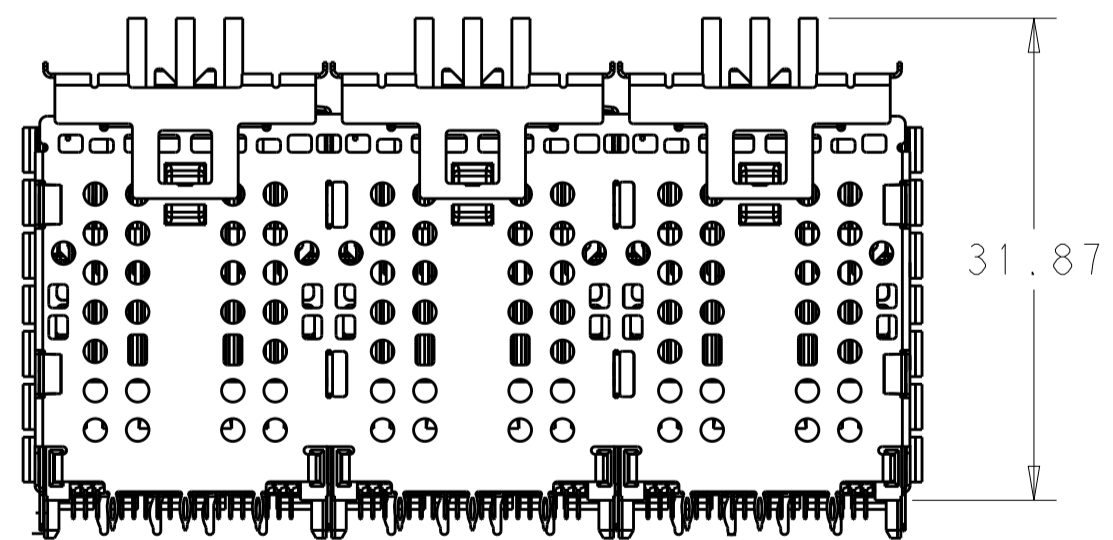

2299924-2
 SCALE 2:1

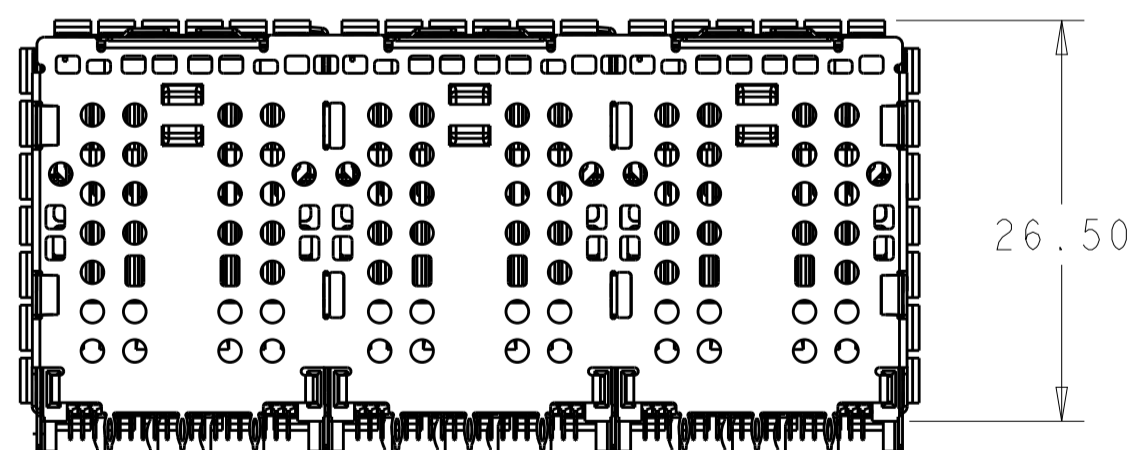

2299924-4
 SCALE 2:1

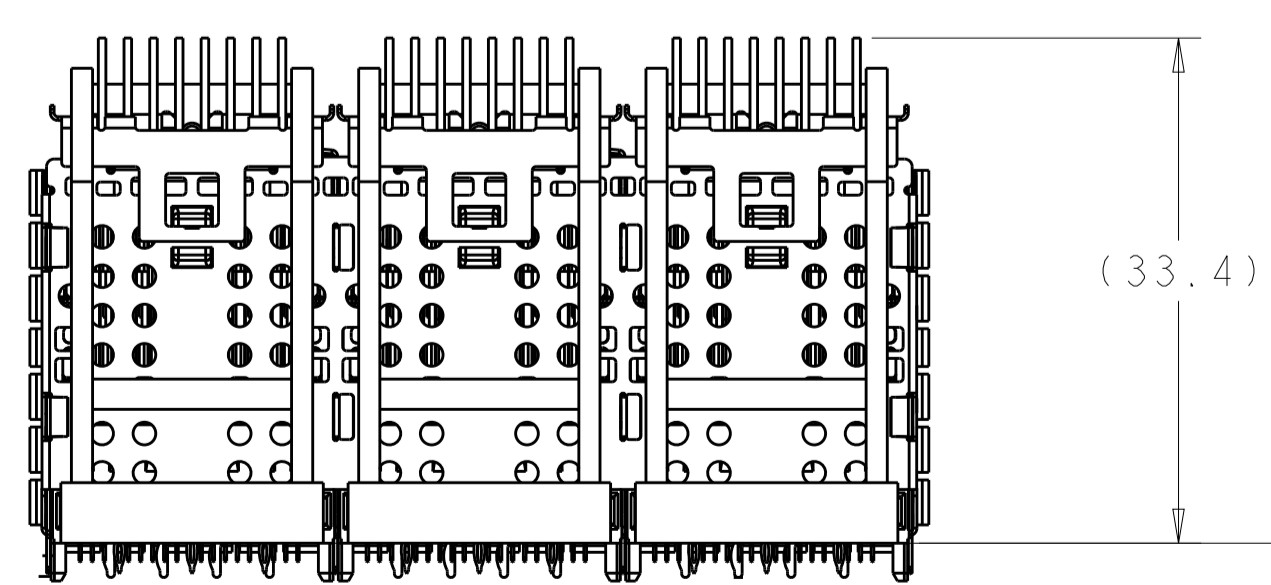

2299924-6
 1-2299924-6
 SCALE 2:1

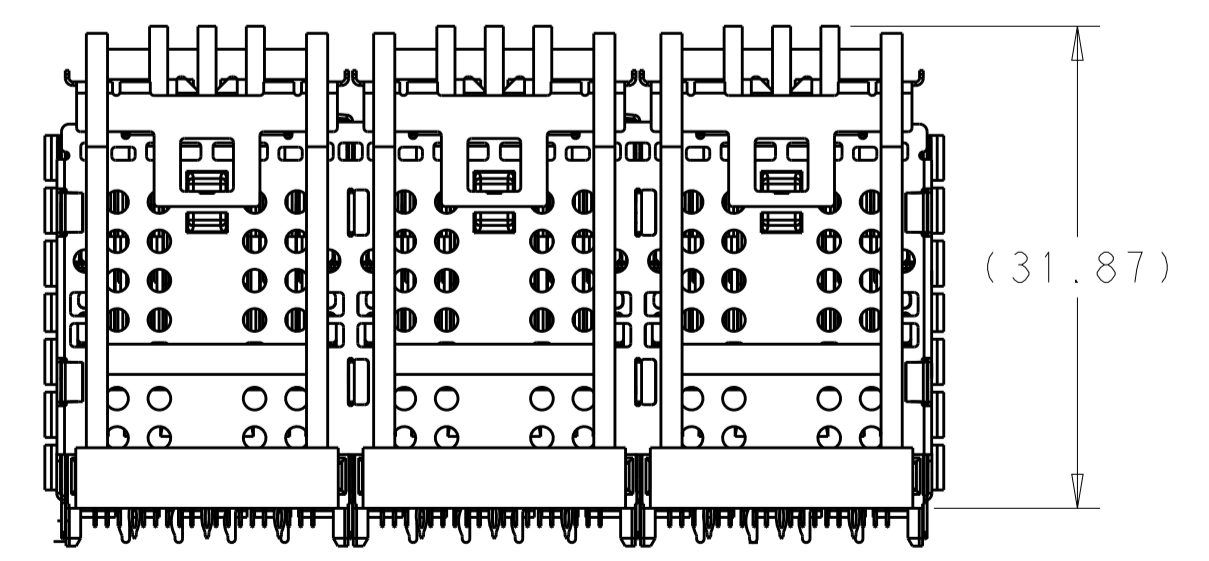

SCALE 2:1

THIS DRAWING IS A CONTROLLED DOCUMENT.		OWN: ARTHUR JIN 20JAN2016	TE Connectivity
DIMENSIONS: mm		CHK: SEAN HAN 20JAN2016	
TOLERANCES UNLESS OTHERWISE SPECIFIED:		APVD: SEAN HAN 20JAN2016	NAME: CAGE AND CONNECTOR ASSEMBLY WITH EMI SPRING FINGERS, THRU BEZEL, 2X3 ZOSFP+ STACKED WITH HS
0 PLC ±	1 PLC ±0.25	PRODUCT SPEC	SIZE: A100779C=2299924
2 PLC ±0.15	3 PLC ±	APPLICATION SPEC	RESTRICTED TO
4 PLC ±	ANGLES ±	WEIGHT	SCALE: 1:1 SHEET 3 OF 8 REV C
MATERIAL: SEE NOTE 1	FINISH: SEE NOTE 2	CUSTOMER DRAWING	

LOC	DIST	REVISIONS					
GP	00	P.	LYR	DESCRIPTION	DATE	DWN	APVD
-	-	-	-	SEE SHEET 1	-	-	-

2299924-3 AS SHOWN, KIT PACKAGE

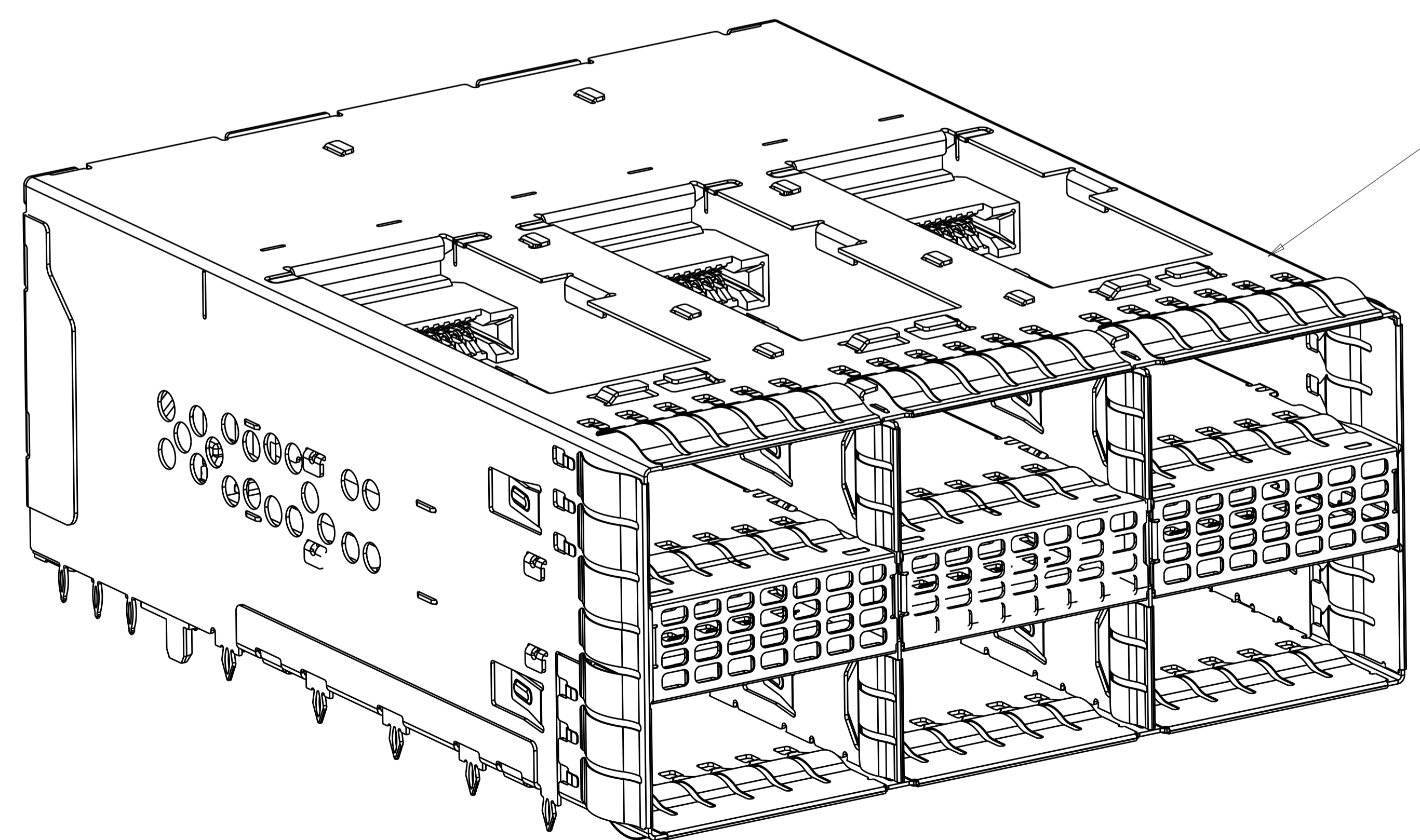
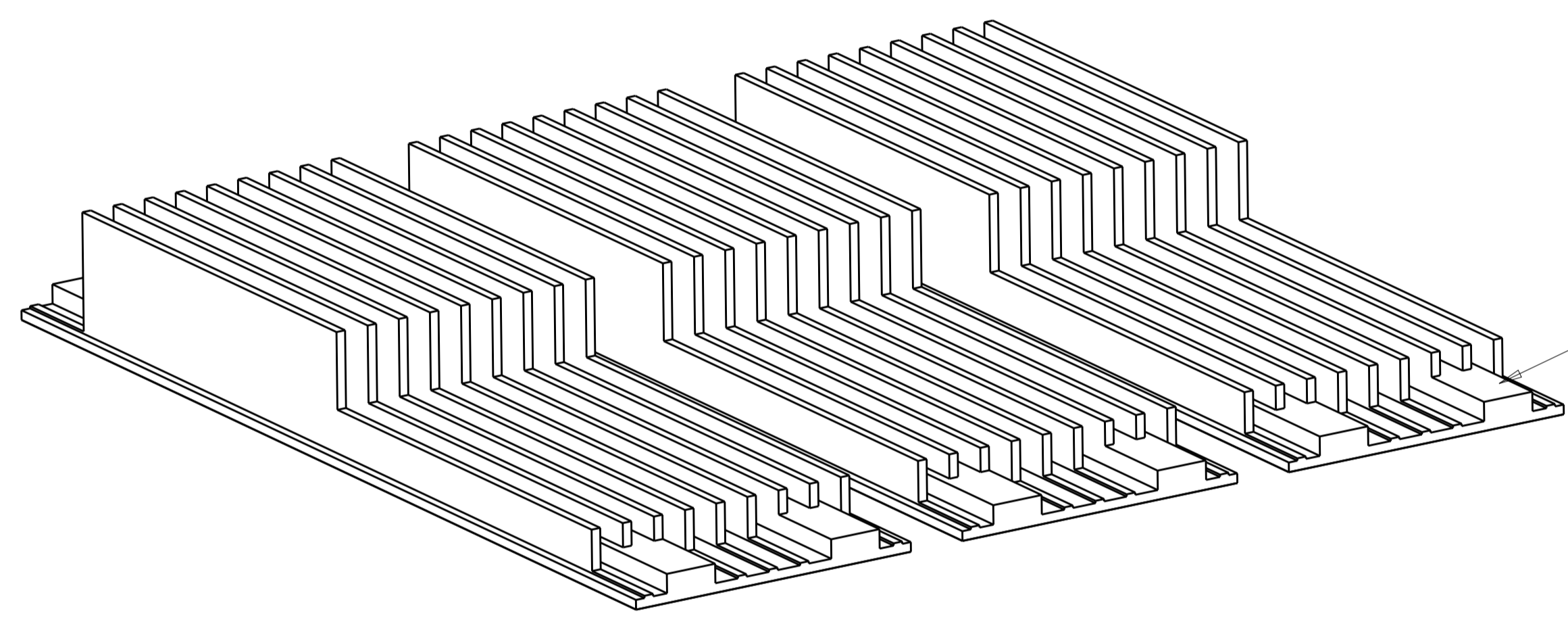
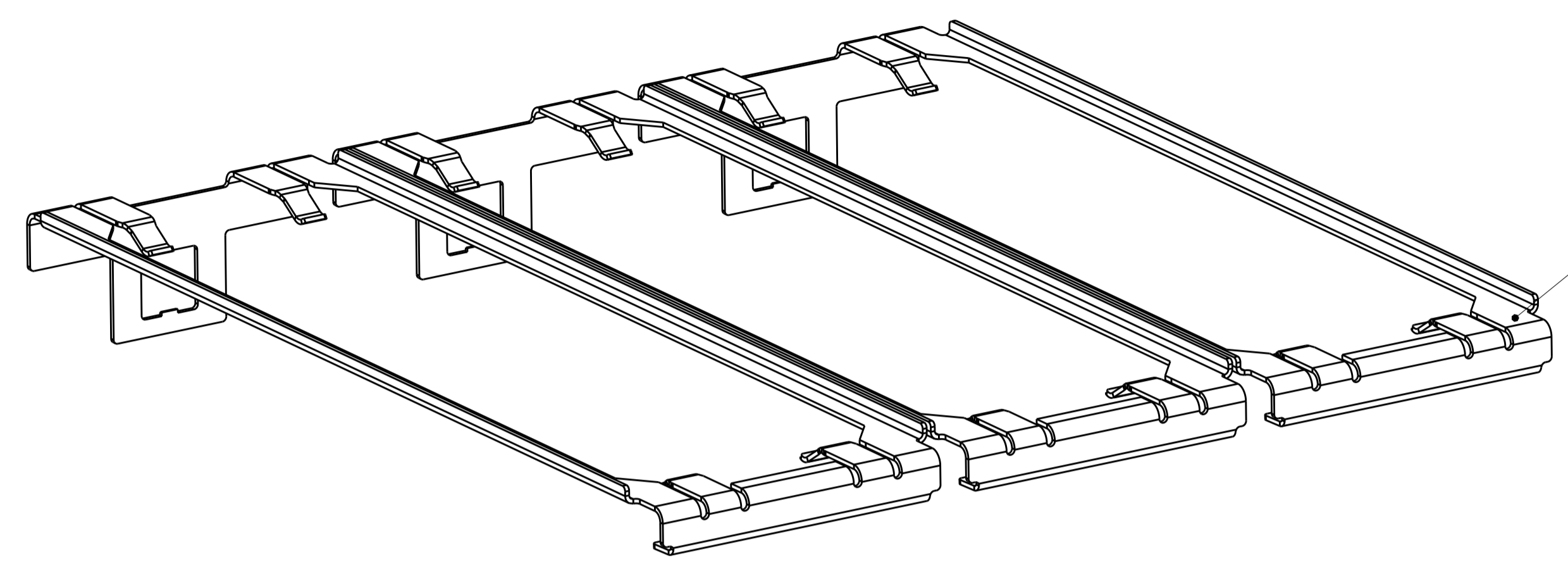

SCALE 4:1

3	1-2300832-7	HEAT SINK CLIP	3
3	1-2304280-3	HEAT SINK	2
1	2299924-4	CAGE AND CONNECTOR ASSEMBLY	1
2299924-3	PART NUMBER	DESCRIPTION	ITEM

THIS DRAWING IS A CONTROLLED DOCUMENT.		DWN: ARTHUR JIN 20JAN2016	TE Connectivity NAME: CAGE AND CONNECTOR ASSEMBLY WITH EMI SPRING FINGERS, THRU BEZEL, 2X3 ZOSFP+ STACKED WITH HS SIZE: A1 CAGE CODE: 00779 DRAWING NO: C=2299924 RESTRICTED TO: -
DIMENSIONS: mm		CHK: SEAN HAN 20JAN2016	
TOLERANCES UNLESS OTHERWISE SPECIFIED:		APVD: SEAN HAN 20JAN2016	
0 PLC ± 1 PLC ±0.25 2 PLC ±0.15 3 PLC ± 4 PLC ± ANGLES ±		PRODUCT SPEC: - APPLICATION SPEC: - WEIGHT: -	
MATERIAL: SEE NOTE 1	FINISH: SEE NOTE 2	CUSTOMER DRAWING	SCALE: 1:1 SHEET 4 OF 8 REV C

LOC	DIST	REV	DATE	BY	APPV
GP	00				

REVISIONS					
REV	DATE	BY	APPV	DESCRIPTION	DATE
-	-	-	-	SEE SHEET 1	-

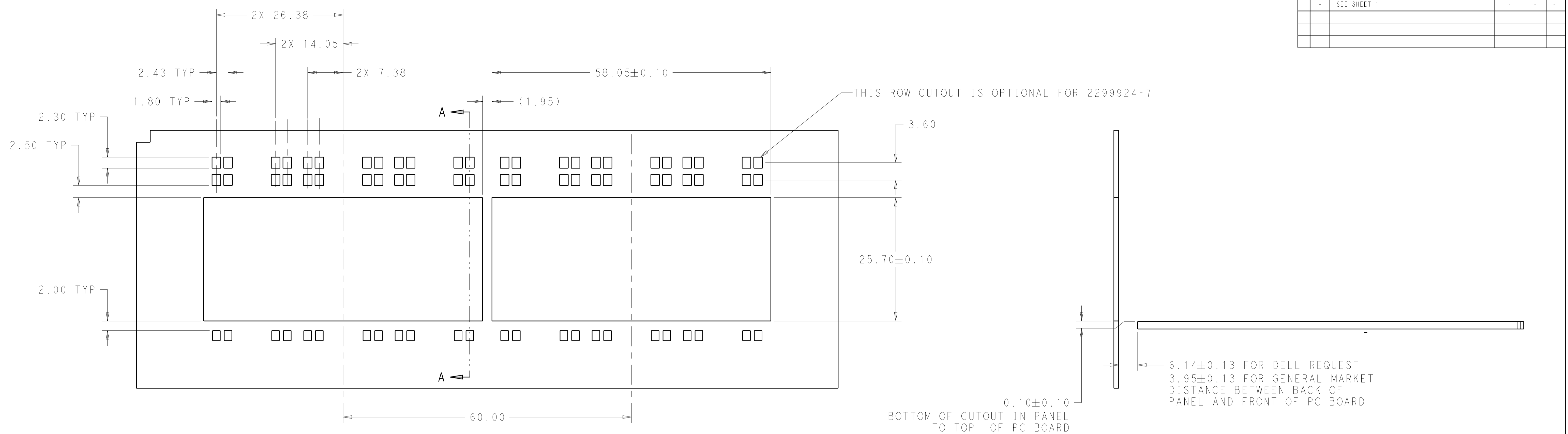

RECOMMENDED PANEL CUTOUT AND PC BOARD, PANEL POSITION
 SCALE 5:2

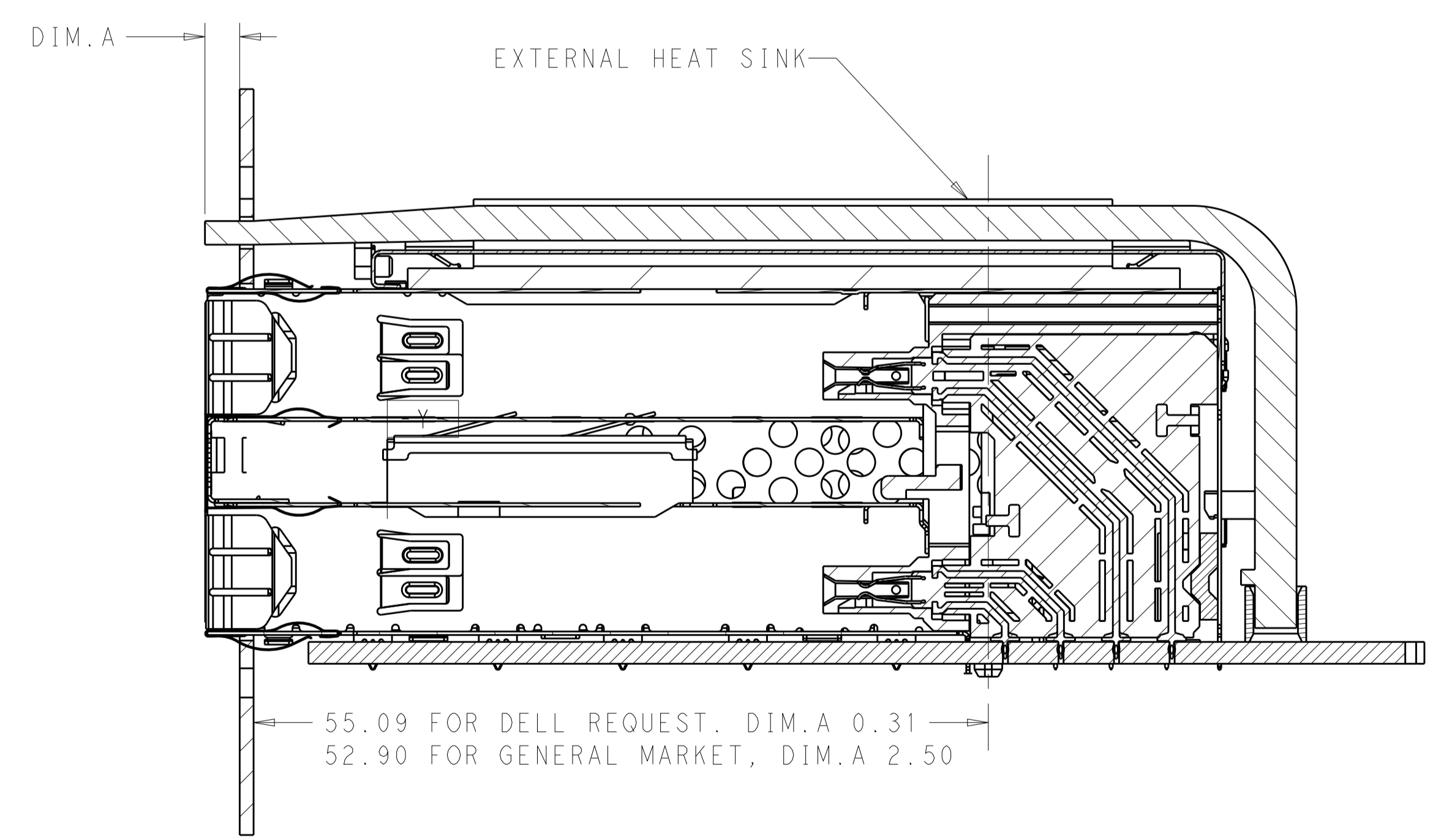

SECTION A-A
 SCALE 3:1

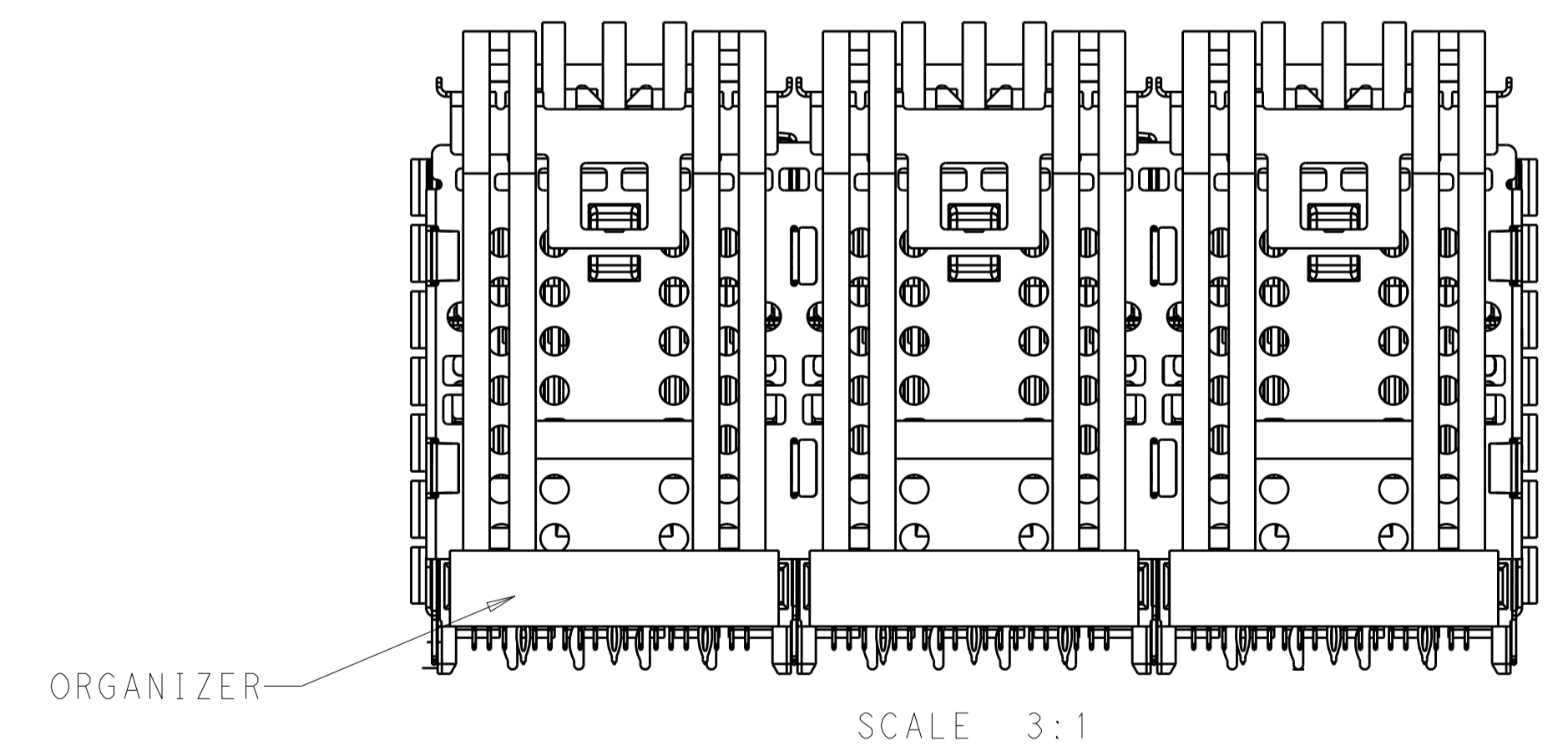

SCALE 3:1

THIS DRAWING IS A CONTROLLED DOCUMENT.		OWN: ARTHUR JIH 20JAN2016	TE Connectivity
DIMENSIONS: mm		CHK: SEAN HAN 20JAN2016	
TOLERANCES UNLESS OTHERWISE SPECIFIED:		APVD: SEAN HAN 20JAN2016	NAME: CAGE AND CONNECTOR ASSEMBLY WITH EMI SPRING FINGERS, THRU BEZEL, 2X3 ZOSFP+ STACKED WITH HS
0 PLC ±	1 PLC ±0.25	PRODUCT SPEC	SIZE: CAGE CODE DRAWING NO. RESTRICTED TO
2 PLC ±0.15	3 PLC ±	APPLICATION SPEC	A100779C=2299924
4 PLC ±	ANGLES ±	WEIGHT	SCALE 1:1 SHEET 5 OF 8 REV C
MATERIAL: SEE NOTE 1	FINISH: SEE NOTE 2	CUSTOMER DRAWING	

LOC	DIST	REVISIONS			
P	LTN	DESCRIPTION	DATE	DMN	APVD
GP	00	SEE SHEET 1	-	-	-

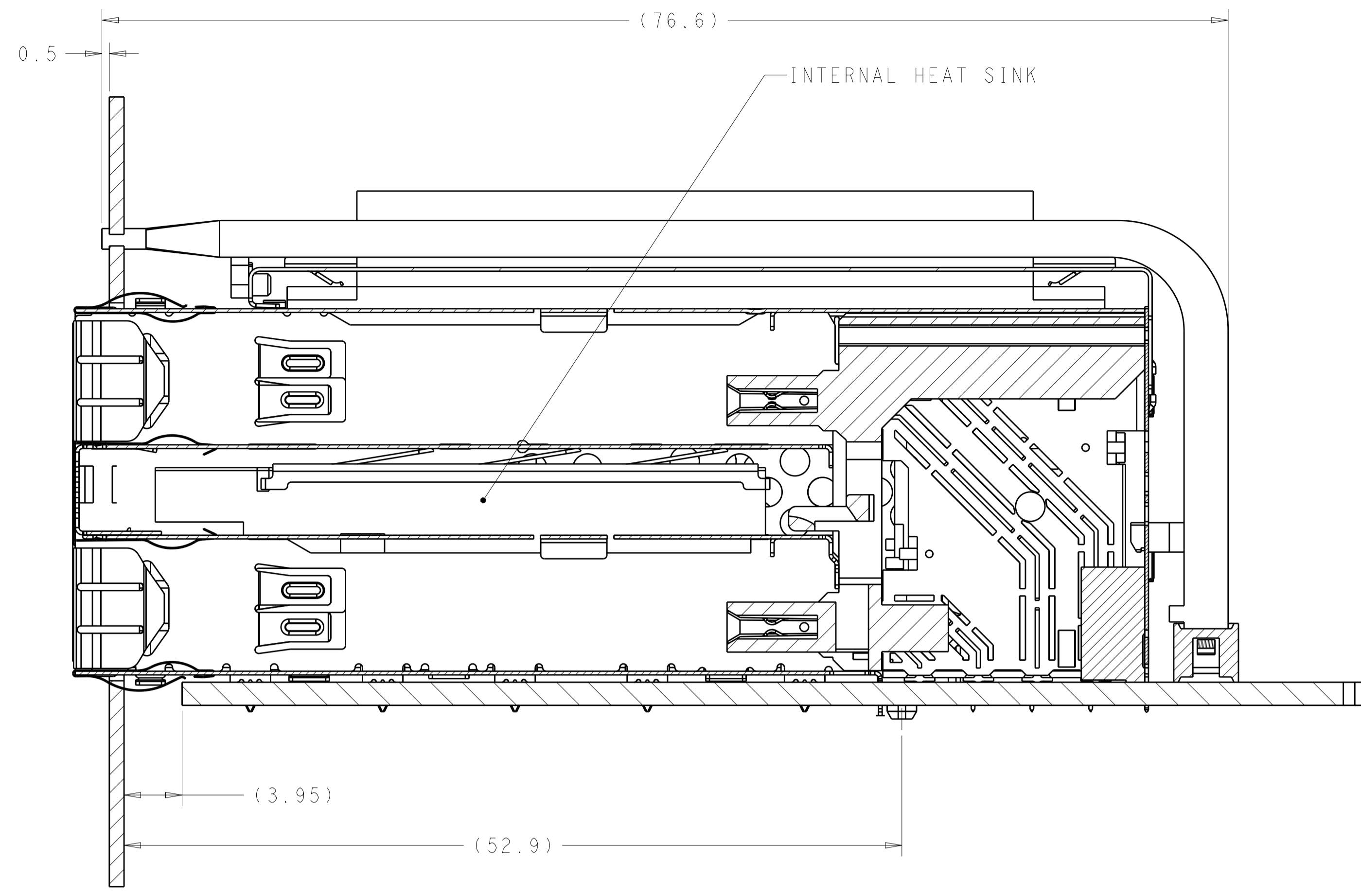

2299924-6
 1-2299924-6
 SECTION V-V
 SCALE 4:1

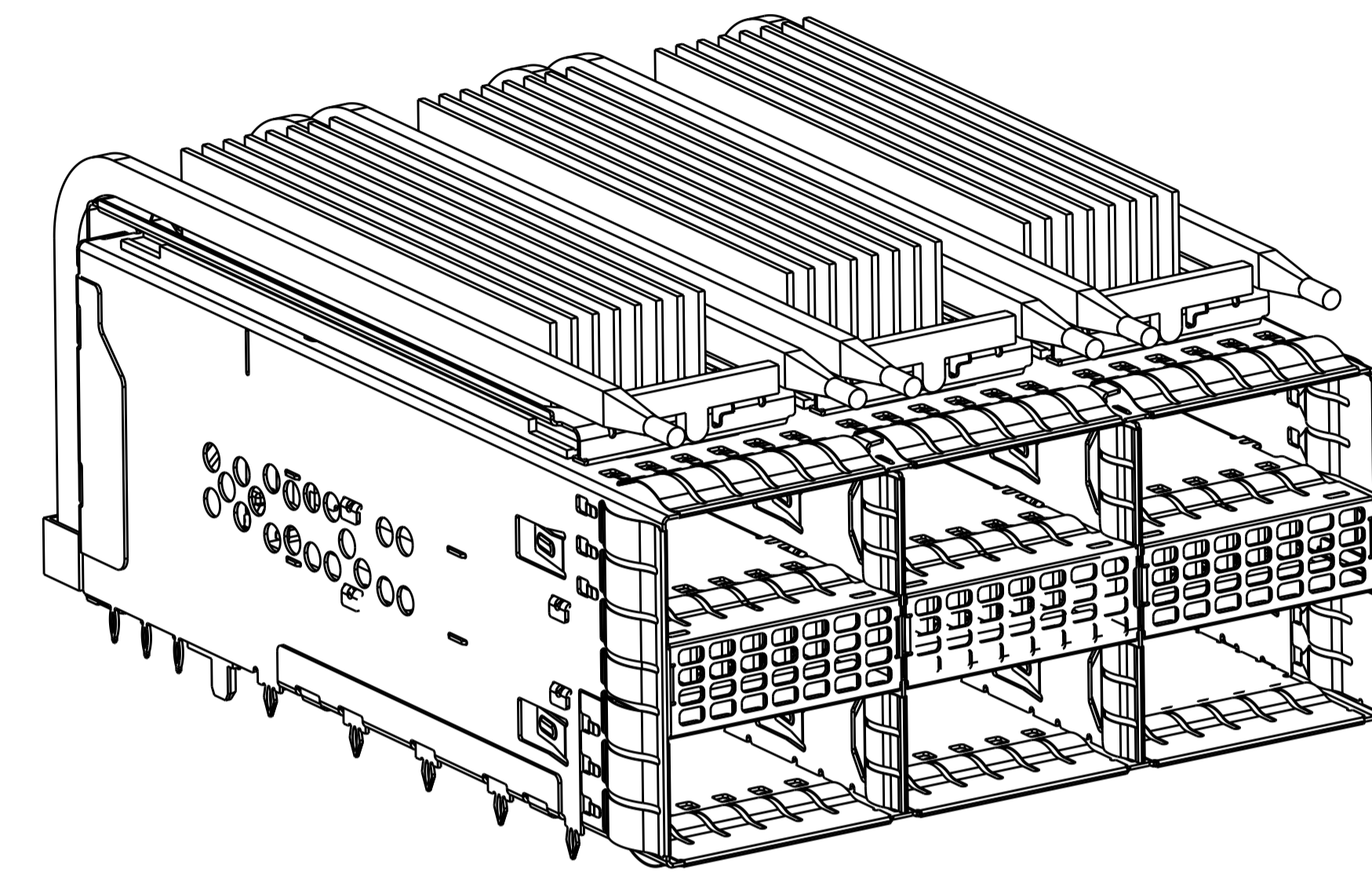

2299924-6
 SCALE 5:2

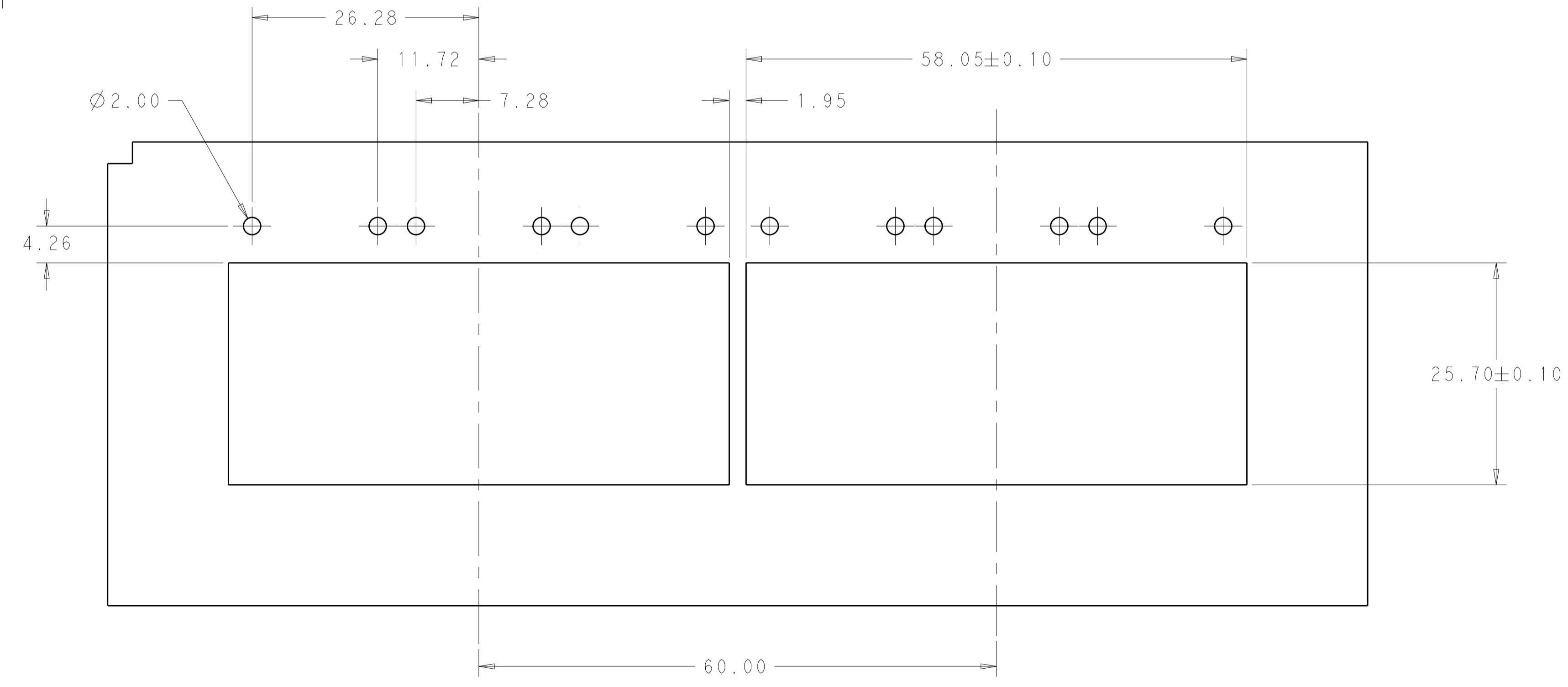

2299924-6
 1-2299924-0
 1-2299924-6
 RECOMMENDED PANEL CUTOUT
 SCALE 5:2

THIS DRAWING IS A CONTROLLED DOCUMENT.		DMN: ARTHUR JIN 20JAN2016	TE Connectivity
DIMENSIONS: mm		CHK: SEAN HAN 20JAN2016	
TOLERANCES UNLESS OTHERWISE SPECIFIED:		APVD: SEAN HAN 20JAN2016	NAME: CAGE AND CONNECTOR ASSEMBLY WITH EMI SPRING FINGERS, THRU BEZEL, 2X3 ZOSFP+ STACKED WITH HS
0 PLC ±	1 PLC ±0.25	PRODUCT SPEC	SIZE: A100779
2 PLC ±0.15	3 PLC ±	APPLICATION SPEC	CAGE CODE: 2299924
4 PLC ±	ANGLES ±	WEIGHT	RESTRICTED TO
MATERIAL: SEE NOTE 1	FINISH: SEE NOTE 2	CUSTOMER DRAWING	SCALE: 1:1 SHEET 6 OF 8 REV C

LOC	DIST	REVISIONS			
GP	00	REV	DATE	BY	APPV
		1	SEE SHEET 1		

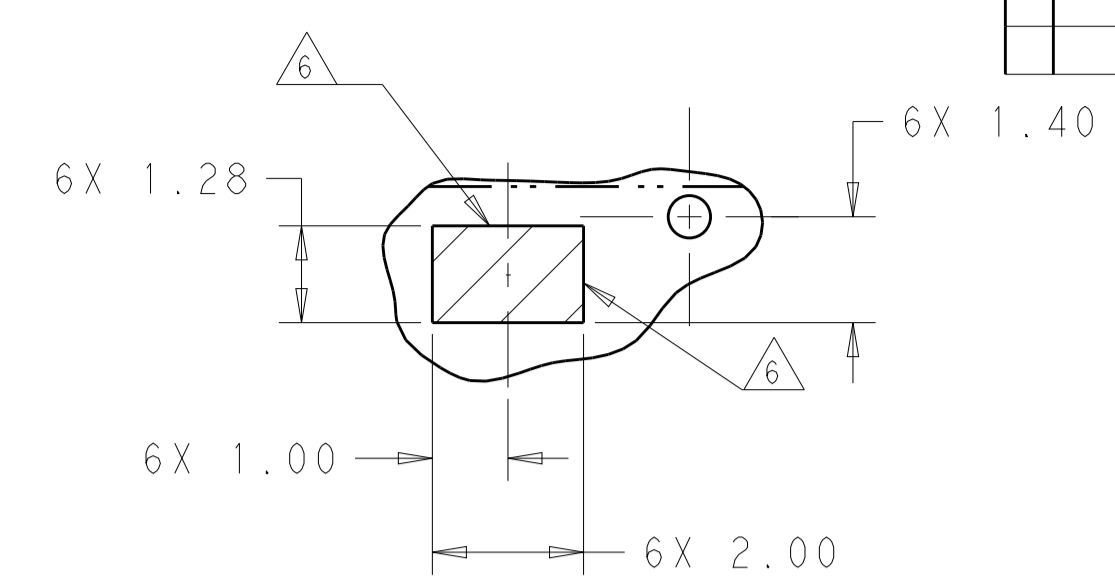
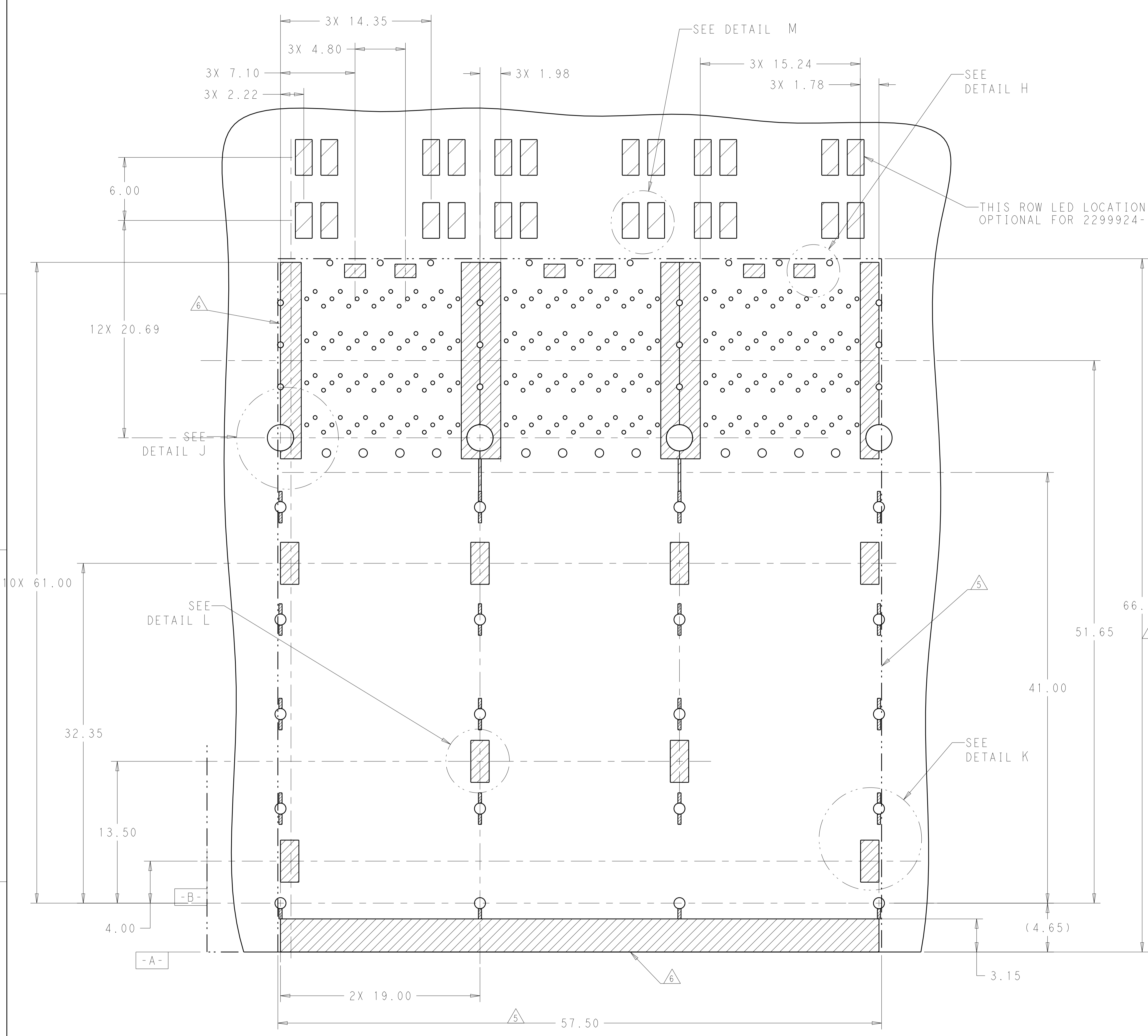

DETAIL H
SCALE 10:1

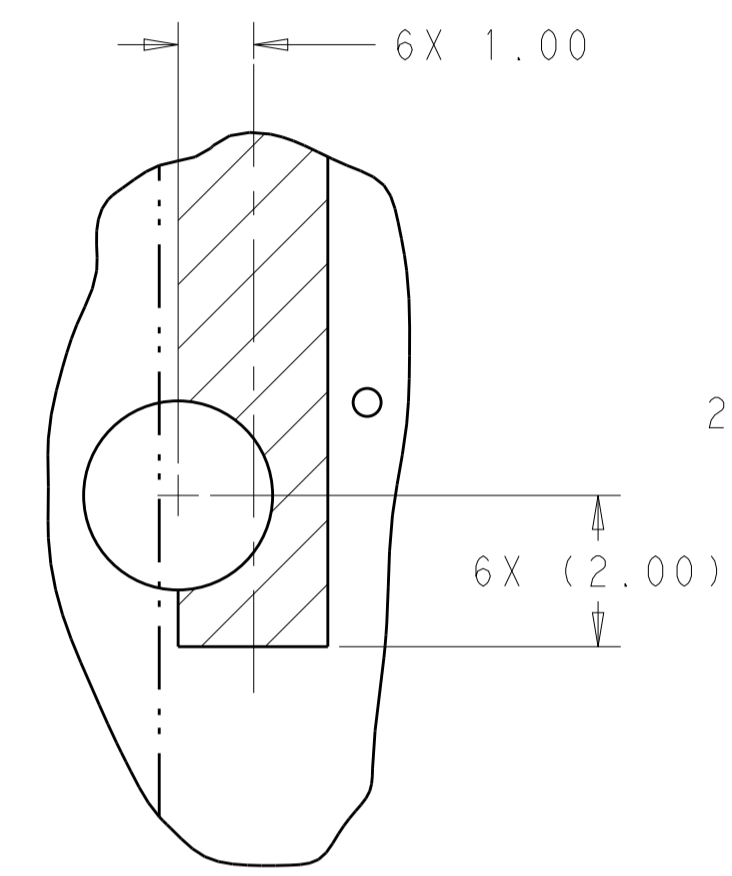

DETAIL J
SCALE 10:1

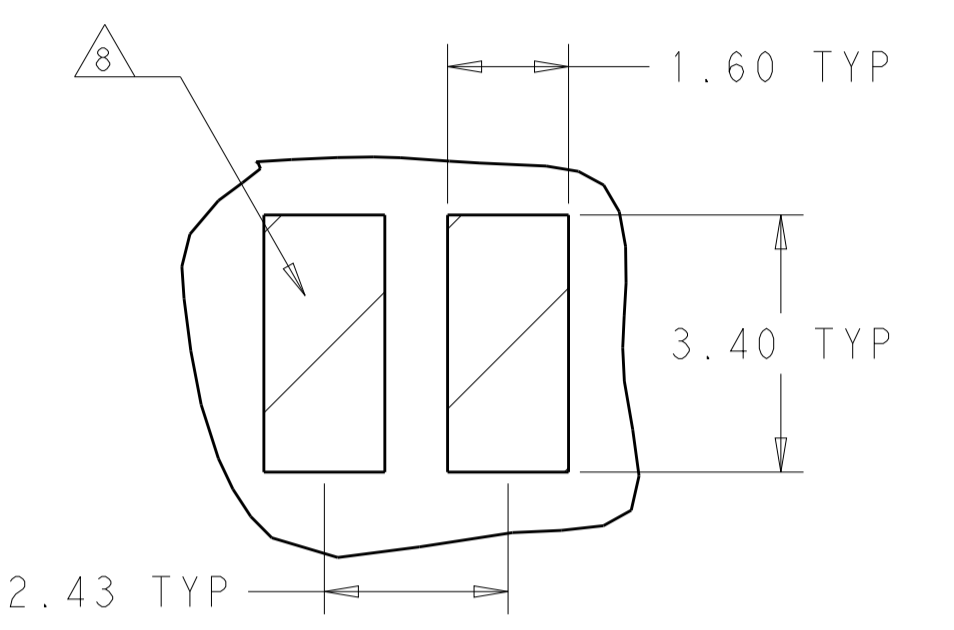

DETAIL M
LED PADS
SCALE 10:1

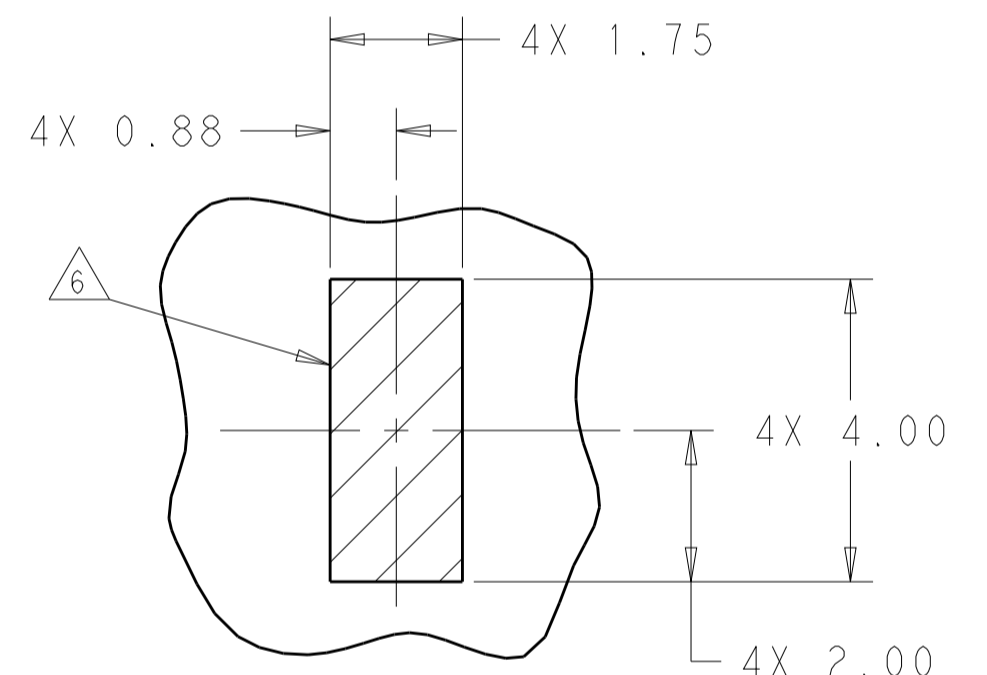

DETAIL L
SCALE 10:1

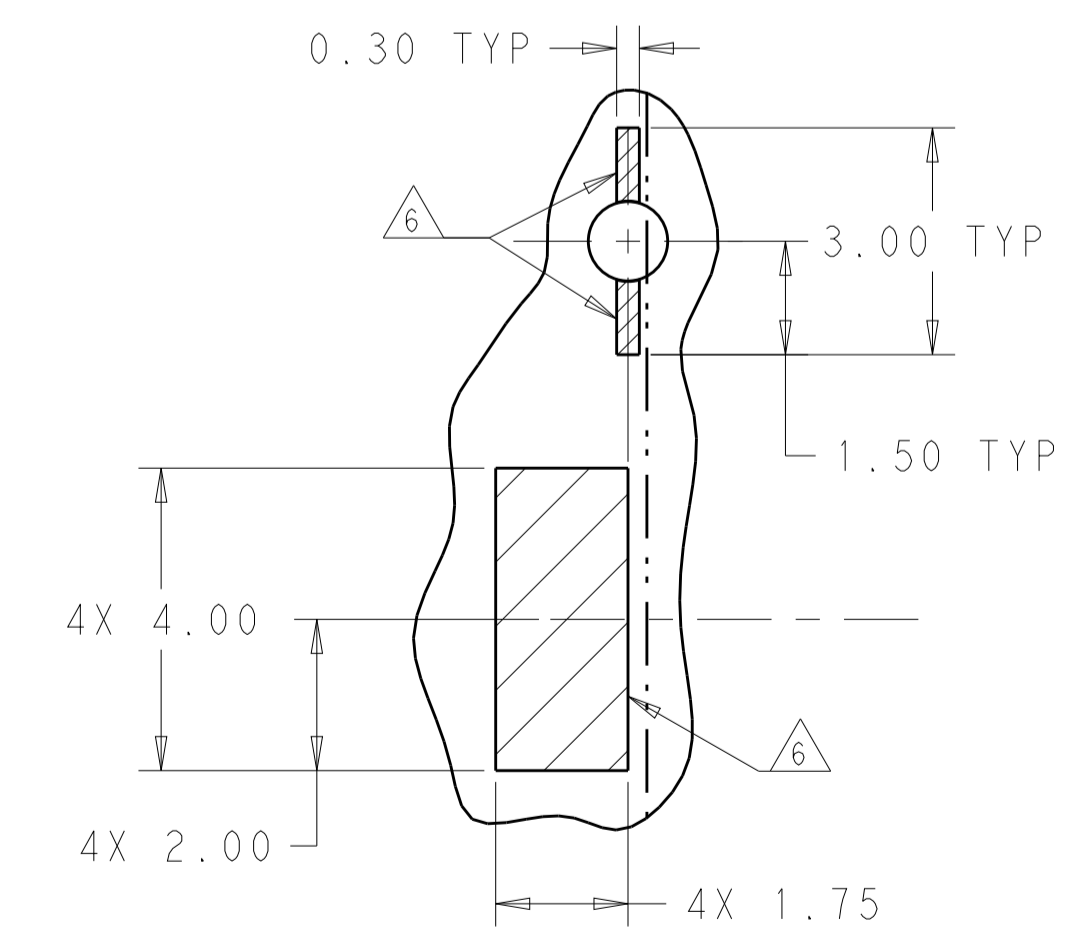

DETAIL K
SCALE 10:1

KEEPOUT AREAS COMPONENT
 SIDE OF BOARD FOR 4 LP
 SCALE 5:1

THIS DRAWING IS A CONTROLLED DOCUMENT.		OWN: ARTHUR JIH 20JAN2016	TE Connectivity
DIMENSIONS: mm		CHK: SEAN HAN 20JAN2016	
TOLERANCES UNLESS OTHERWISE SPECIFIED:		APPV: SEAN HAN 20JAN2016	NAME: CAGE AND CONNECTOR ASSEMBLY WITH EMI SPRING FINGERS, THRU BEZEL, 2X3 ZOSFP+ STACKED WITH HS
0 PLC ±	1 PLC ±0.25	PRODUCT SPEC	SIZE: CAGE CODE DRAWING NO
2 PLC ±0.15	3 PLC ±	APPLICATION SPEC	RESTRICTED TO
4 PLC ±	ANGLES ±	WEIGHT	A100779C=2299924
MATERIAL: SEE NOTE 1	FINISH: SEE NOTE 2	CUSTOMER DRAWING	SCALE 1:1 SHEET 8 OF 8 REV C