

Oct.1.2018 Copyright 2018 HIROSE ELECTRIC CO., LTD. All Rights Reserved.
 In case that the application demands a high level of reliability, such as automotive,
 please contact a company representative for further information.

COUNT	DESCRIPTION OF REVISIONS	BY	CHKD	DATE	COUNT	DESCRIPTION OF REVISIONS	BY	CHKD	DATE
1	DIS-C-000585	T.K	E.K	07.07.27					

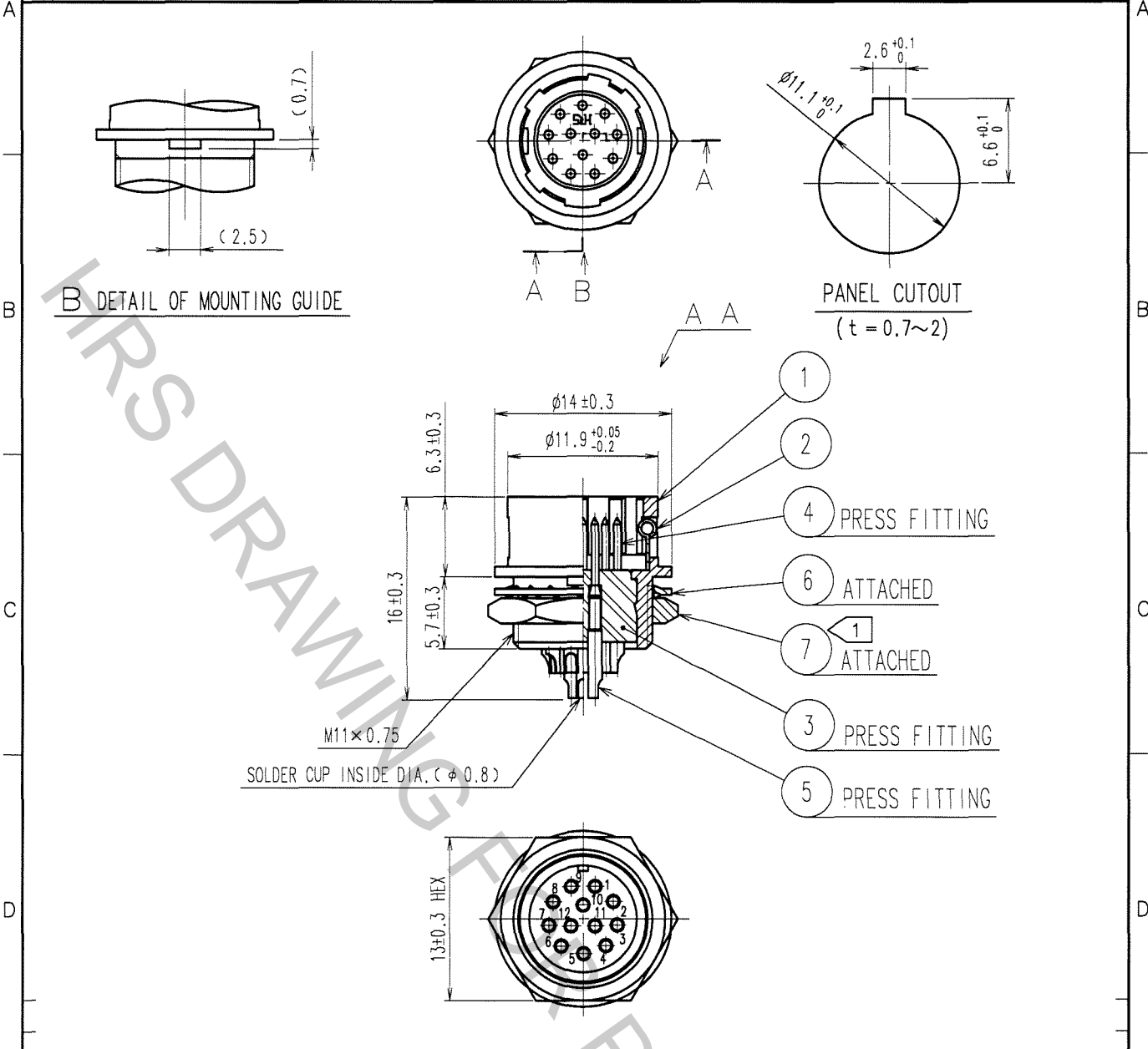

NOTE ① THE RECOMMENDED CLAMP TORQUE OF REF. NO. ⑦ TO BE 2 N · m.
 LOCTITE 242, HENKEL JAPAN OR EQUIVALENT IS RECOMMENDED TO
 PREVENT REF. NO. ⑦ FROM LOOSENING.

3	POLYAMIDE	(BLACK) UL94V-0	7	BRASS	NICKEL PLATING
2	STAINLESS STEEL		6	PHOSPHOR BRONZE	NICKEL PLATING
1	ZINC ALLOY	MATTE FINISH NICKEL PLATED	5	BRASS	SILVER PLATING 2μ m min.
			4	BRASS	
NO.	MATERIAL	FINISH, REMARKS	NO.	MATERIAL	FINISH, REMARKS

CODE NO. (OLD)	DRAWN	DESIGNED	CHECKED	APPROVED	RELEASED
CL	D.MATSUNE	D.MATSUNE	E.KUNII	M.SATO	
	'05 10 01	'05 10 01	'05 10 03	'05 10 14	

TO
R

SCALE	DRAWING NO.	PART NO.
2 : 1	EDC4-020553-73	HR10A-10R-12P(73)
UNITS	CODE NO.	
mm	CL110-0404-5-73	

