

Oct.1.2018 Copyright 2018 HIROSE ELECTRIC CO., LTD. All Rights Reserved.
 In case that the application demands a high level of reliability, such as automotive,
 please contact a company representative for further information.

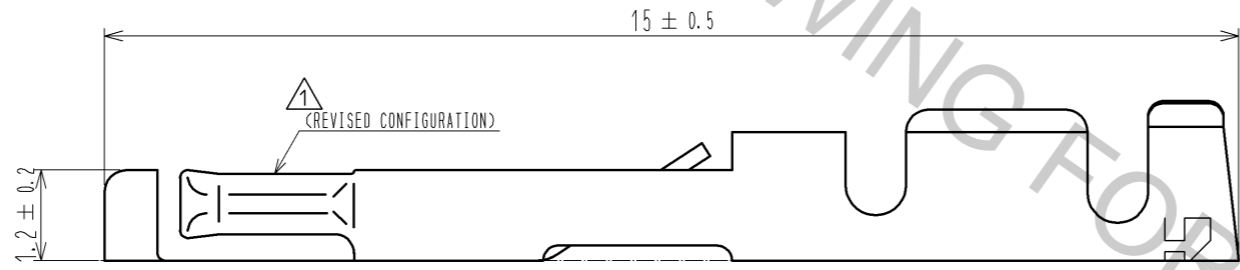
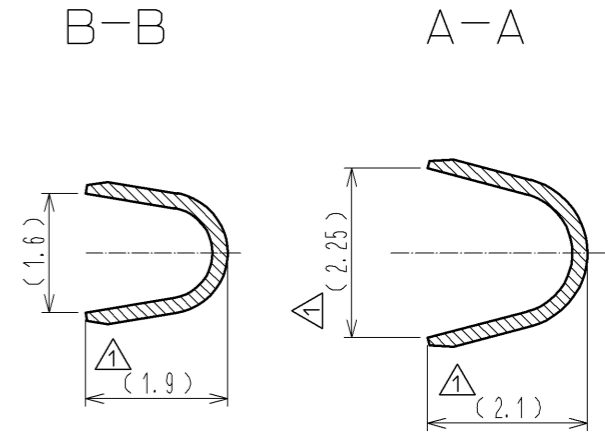
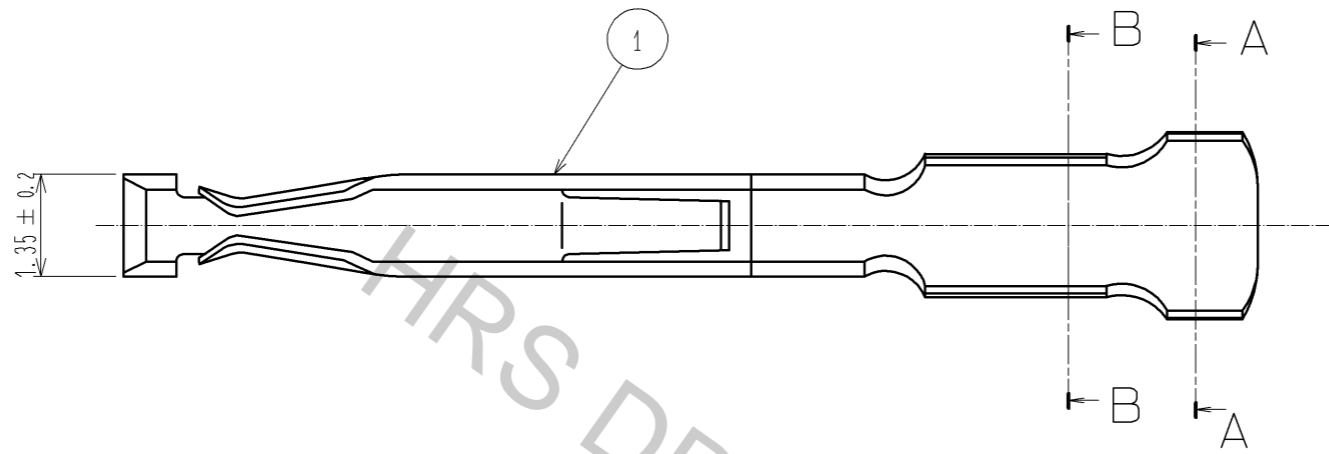
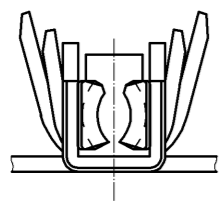

NOTES
 1 THIS PRODUCT IS APPLY TO THE WIRE #20 TO #25(WIRE JACKET DIAMETER ϕ 1.7 MAX.)
 2 PER PACK:100 CONTACTS.
 3 CONTACT AREA : GOLD PLATING 0.2 μ m min.
 TERMINAL AREA : NICKEL PLATING 2 μ m min.
 UNDER PLATING : NICKEL 2 μ m min.

1	PHOSPHOR BRONZE	3						
NO.	MATERIAL	FINISH	REMARKS	NO.	MATERIAL	FINISH	REMARKS	
UNITS		SCALE	COUNT	DESCRIPTION OF REVISIONS		DESIGNED	CHECKED	DATE
mm		10:1	5	DIS-C-001336		DS. MATSUNE	SU. OBARA	09.06.17
HRS HIROSE ELECTRIC CO., LTD.		APPROVED : MO. SATOH	08.11.12	DRAWING NO.		EDC3-116078-00		
		CHECED : TH. KAMEYA	08.11.11	PART NO.		HR34B-SC1-111		
		DESIGNED : DS. MATSUNE	08.11.11	CODE NO.		CL134-0051-7-00		
		DRAWN : DS. MATSUNE	08.11.11					