

Oct.1.2018 Copyright 2018 HIROSE ELECTRIC CO., LTD. All Rights Reserved.  
 In case that the application demands a high level of reliability, such as automotive,  
 please contact a company representative for further information.

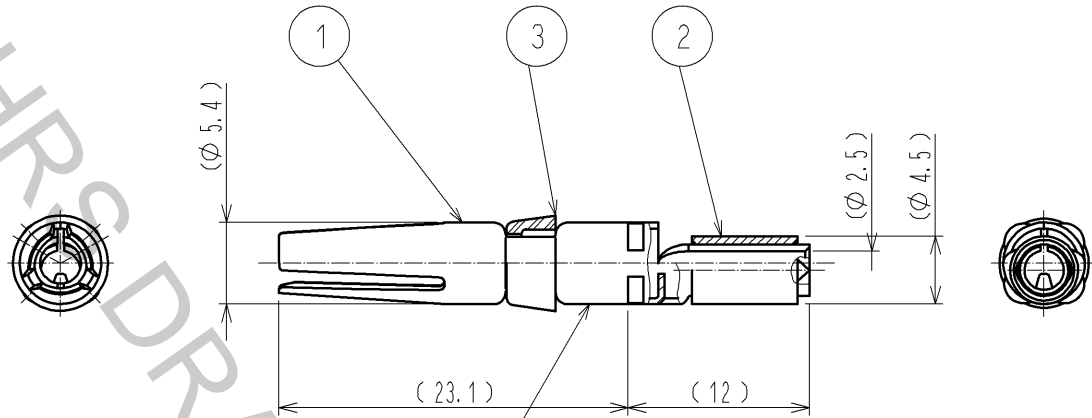

MARKING POSITION OF APPLICABLE WIRE SIZE '14'

- NOTES
- 1 APPLICABLE CRIMPING TOOL: JIS C 9711 (COMPRESSION TOOLS FOR WIRE CONNECTORS OF INTERIOR WIRING)  
 APPLICABLE DIE SIZE: 2
  - 2 APPLICABLE EXTRACTION TOOL: HR41-TP
  - 3 ONE BAG INCLUDES 3PCS OF PRODUCTS.
  - 4 PLATING (REF. NO. ①)  
 CONTACT AREA: GOLD 0.76 μm min.  
 TERMINAL AREA: TIN 1 μm min.
  - ① OTHERS: NIKEL 2 μm min.

2	COPPER	TIN PLATING						
1	COPPER ALLOY	4	3	POLYBUTYLENE TEREPHTHALATE	(WHITE) UL94V-0			
NO.	MATERIAL	FINISH	REMARKS	NO.	MATERIAL	FINISH	REMARKS	
UNITS mm		SCALE 2 : 1	COUNT 1	DESCRIPTION OF REVISIONS DIS-C-002929		DESIGNED KN. IKEHARA	CHECKED HY. KOBAYASHI	DATE 13. 09. 26
<b>HRS</b> HIROSE ELECTRIC CO., LTD.	APPROVED	: SU. OBARA	11. 09. 01	DRAWING NO.		EDC4-117549-01		
	CHECKED	: HY. KOBAYASHI	11. 09. 01	PART NO.		HR41-SC-121(01)		
	DESIGNED	: HT. ZENBA	11. 08. 30	CODE NO.		CL141-0003-2-01		
	DRAWN	: HT. ZENBA	11. 08. 30			1/1		