

Oct.1.2018 Copyright 2018 HIROSE ELECTRIC CO., LTD. All Rights Reserved.
 In case that the application demands a high level of reliability, such as automotive,
 please contact a company representative for further information.

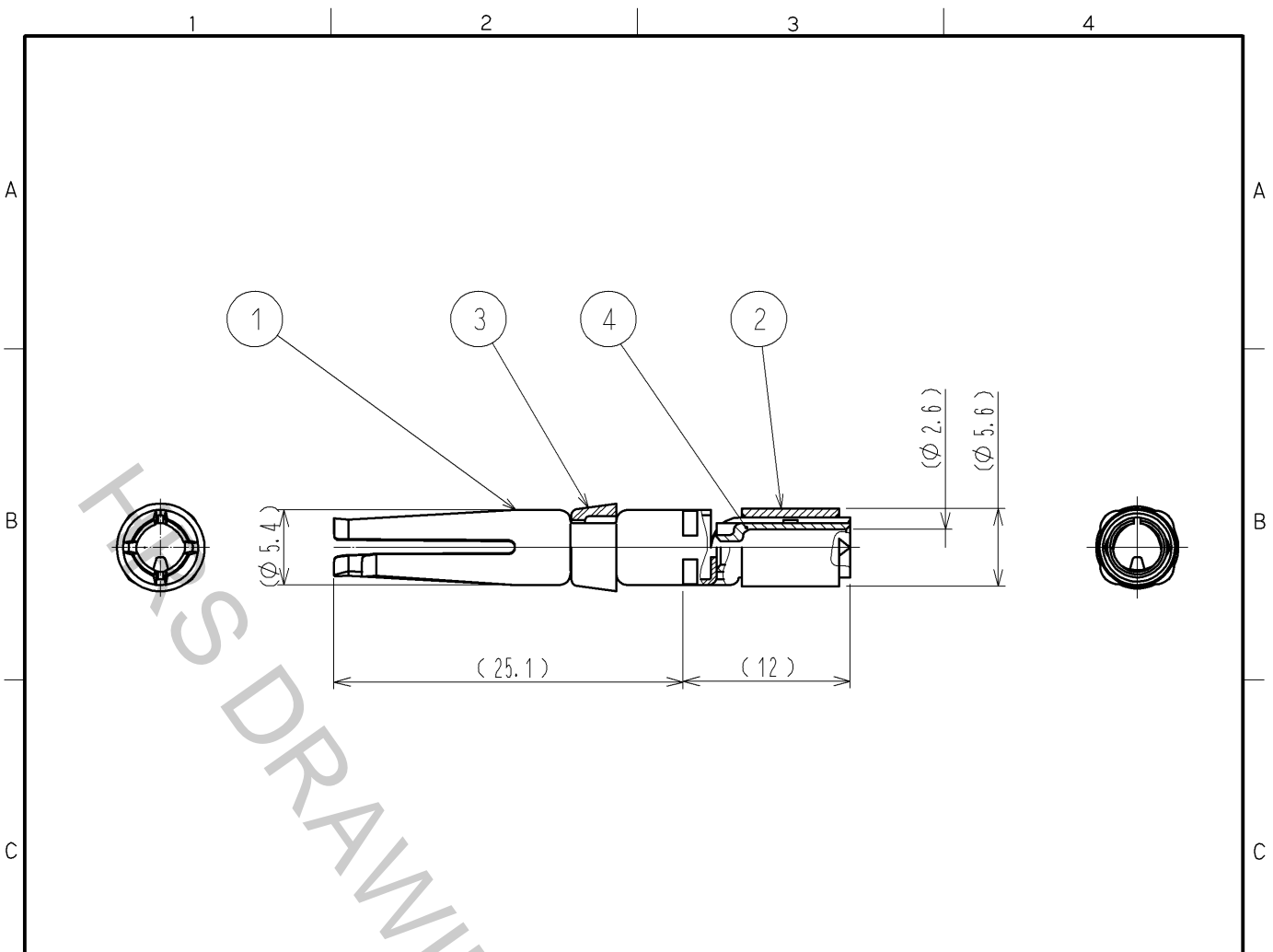

NOTES 1 APPLICABLE CRIMPING TOOL: JIS C 9711
 (COMPRESSION TOOLS FOR WIRE CONNECTORS OF INTERIOR WIRING)
 APPLICABLE DISE SIZE: 5.5
 2 APPLICABLE EXTRACTION TOOL: HR41-TP
 3 ONE BAG INCLUDES 5PCS OF PRODUCTS.
 4 PLATING (REF. NO. ①)
 CONTACT PLATING: GOLD 0.2 μm min.
 TERMINAL AREA: TIN 1 μm min.
 OTHERS: NIKEL 2 μm min.
 ⚠ (DELETED)

2	COPPER ALLOY	TIN PLATING	4	COPPER ALLOY	TIN PLATING			
1	COPPER ALLOY	4	3	POLYBUTYLENE TEREPHTHALATE	(WHITE) UL94V-0			
NO.	MATERIAL	FINISH .	REMARKS	NO.	MATERIAL	FINISH .	REMARKS	
UNITS mm		SCALE 2 : 1	COUNT 1	DESCRIPTION OF REVISIONS DIS-C-002929		DESIGNED KN. IKEHARA	CHECKED HY. KOBAYASHI	DATE 13. 09. 26
HIROSE ELECTRIC CO., LTD.		APPROVED : SU. OBARA	12. 06. 20	DRAWING NO.		EDC4-117700-00		
		CHECKED : HY. KOBAYASHI	12. 06. 20	PART NO.		HR41-SC-151		
		DESIGNED : TY. SUZUKI	12. 06. 20	CODE NO.		CL141-0011-0-00		
		DRAWN : TY. SUZUKI	12. 06. 20					