

PCB LAYOUT

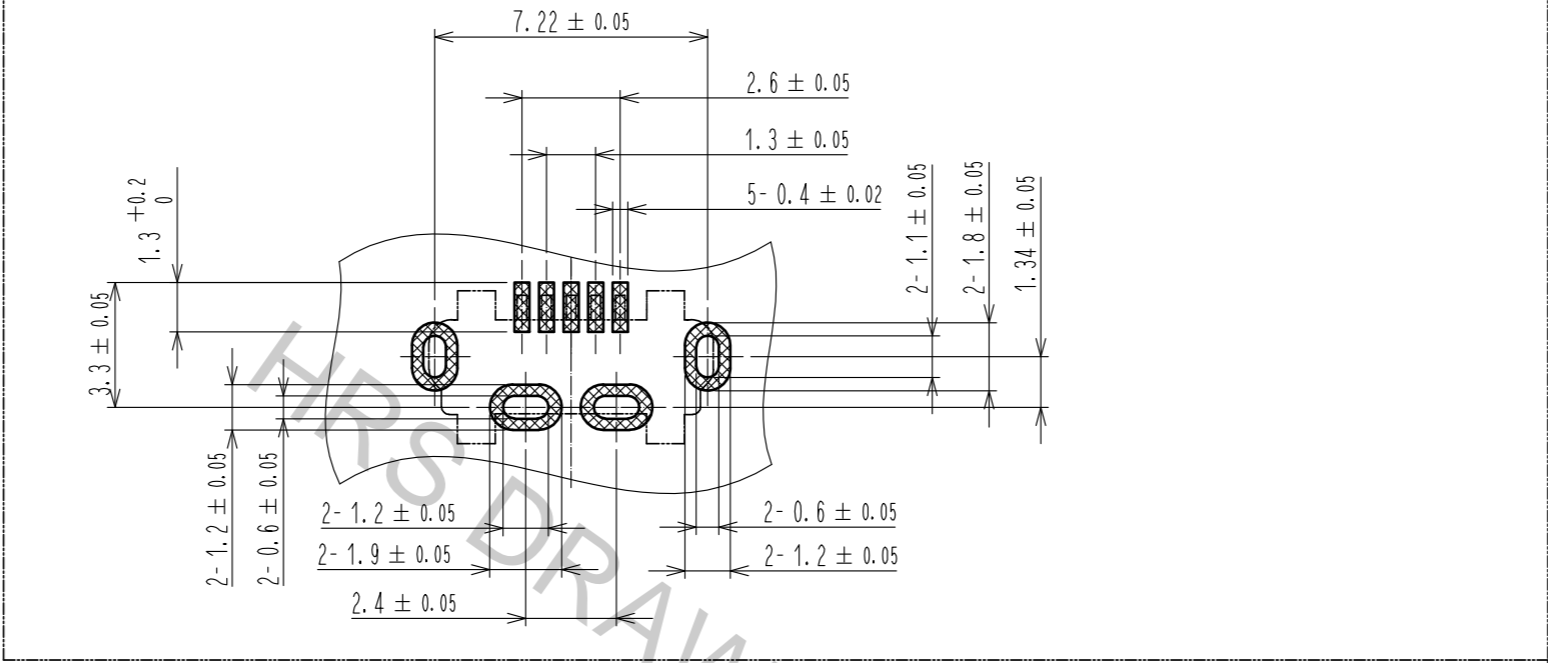

PICK AND PLACE CAP

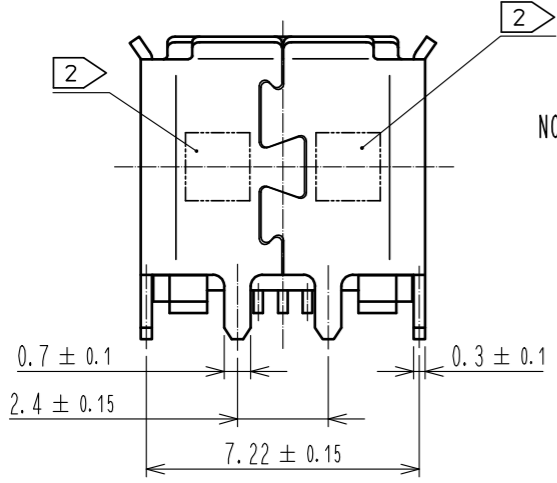
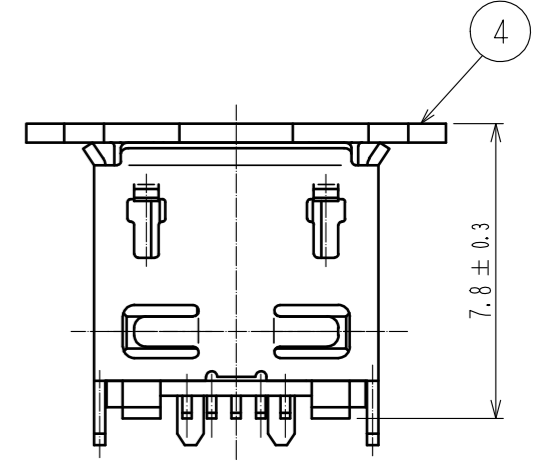
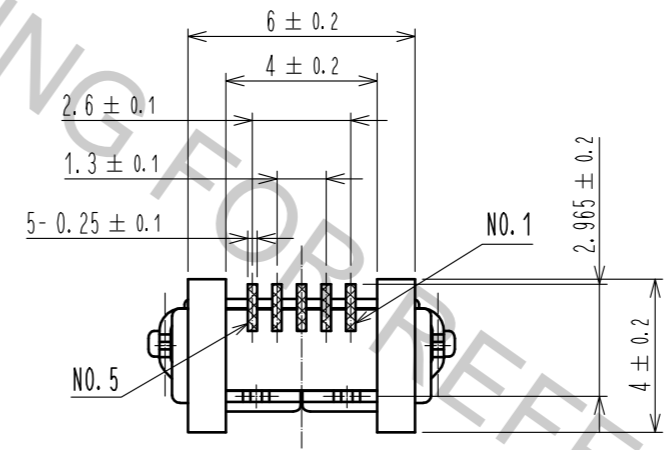
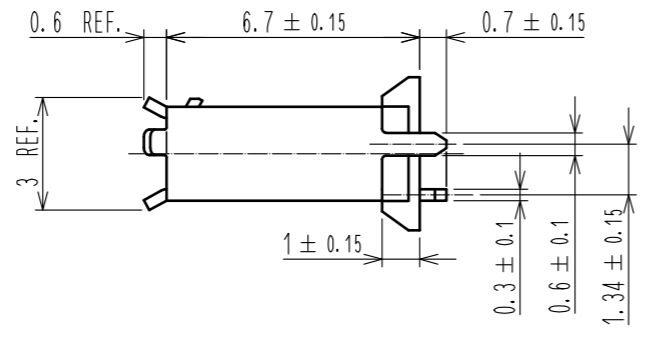
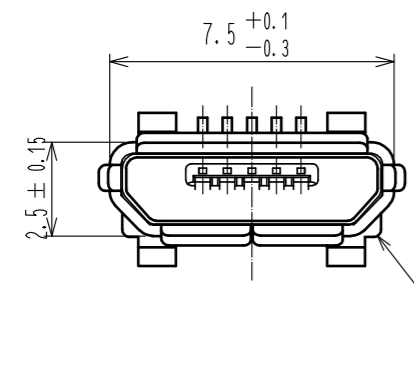
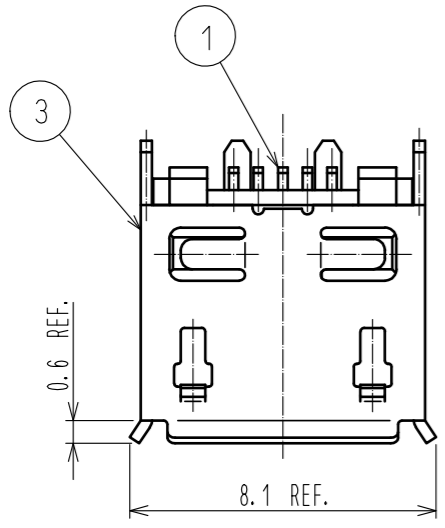
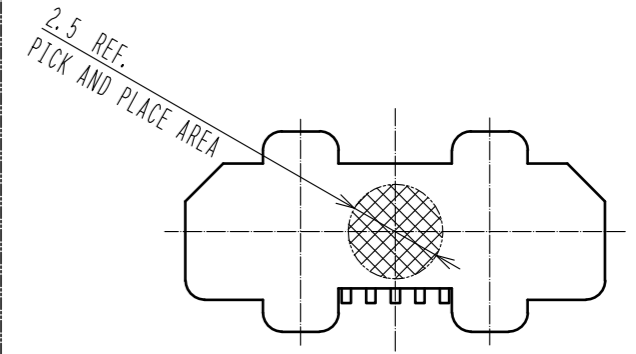

- NOTE
- 1 CO-PLANARITY IS WITHIN 0.08.
  - 2 LOT No. SHALL BE INDICATED AT THE POSITION AS SHOWN.
  - 3 PLATING  
 CONTACT AREA : GOLD PLATE 0.75 μm MIN.  
 LEAD AREA : GOLD PLATE 0.05 μm MIN.  
 UNDER PLATING : NICKEL 2 μm MIN.
  - 4 PACKING  
 300 PCS PER TRAY.
  - 5 AS FOR PART No. 3, THE PERFORMANCE REMAINS GOOD EVEN IF THERE IS A RUBBING WOUND BY THE ASSEMBLY PROCESS. AND THE PERFORMANCE REMAINS GOOD EVEN IF THERE IS A DIFFERENCE OF THE COLOR OF PLATING WITH THE MANUFACTURING LOT.

2	LCP	BLACK	UL94V-0	5	PS			
1	COPPER ALLOY	3		4	POLYAMIDE RESIN			
				3	STAINLESS STEEL	UNDER PLATING: NICKEL 0.2 μm MIN. OVER PLATING : TIN 1μm MIN. LUBRICANT		
NO.	MATERIAL	FINISH	REMARKS	NO.	MATERIAL	FINISH . REMARKS		
UNITS	mm	SCALE	5 : 1	COUNT	DESCRIPTION OF REVISIONS	DESIGNED	CHECKED	DATE
<b>HRS</b> HIROSE ELECTRIC CO., LTD.		APPROVED	: NM. NISHIMATSU	15.10.27	DRAWING NO.	EDC-126723-30-00		
		CHECKED	: KN. ICHIKAWA	15.10.27	PART NO.	ZX80-B-5P(30)		
		DESIGNED	: TS. ITO	15.10.27	CODE NO.	CL242-0051-0-30		
		DRAWN	: AK. AKIYAMA	15.10.27				

Oct.1.2018 Copyright 2018 HIROSE ELECTRIC CO., LTD. All Rights Reserved.  
 In case that the application demands a high level of reliability, such as automotive,  
 please contact a company representative for further information.

4 PACKING (QTY. 3000PCS)

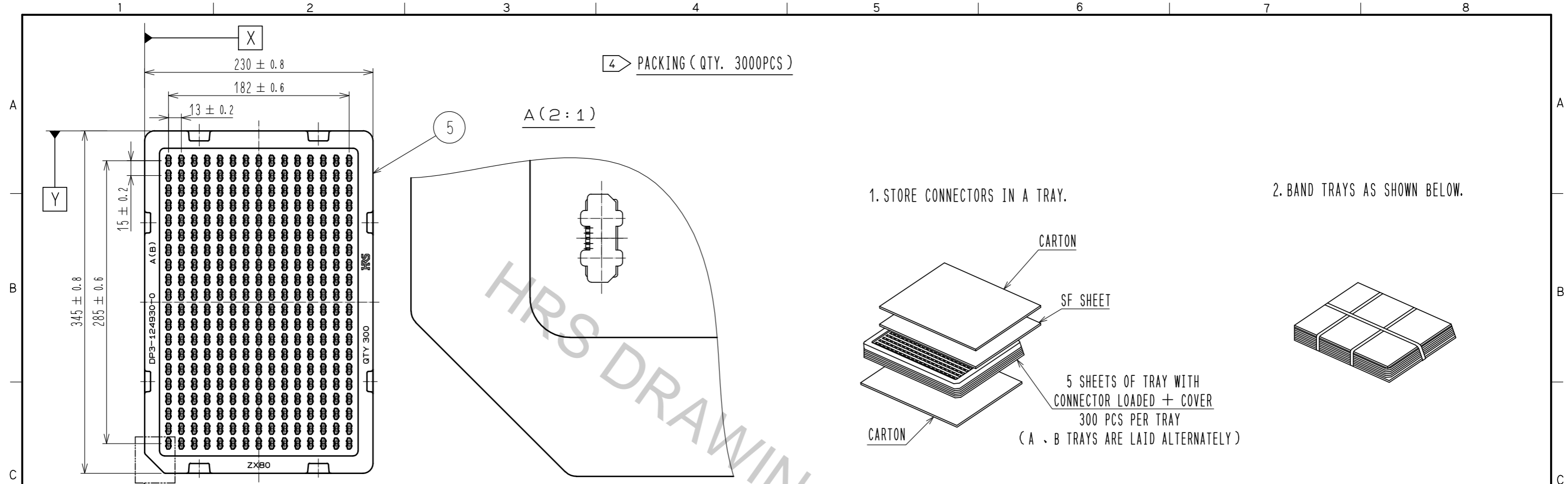

1. STORE CONNECTORS IN A TRAY.

2. BAND TRAYS AS SHOWN BELOW.

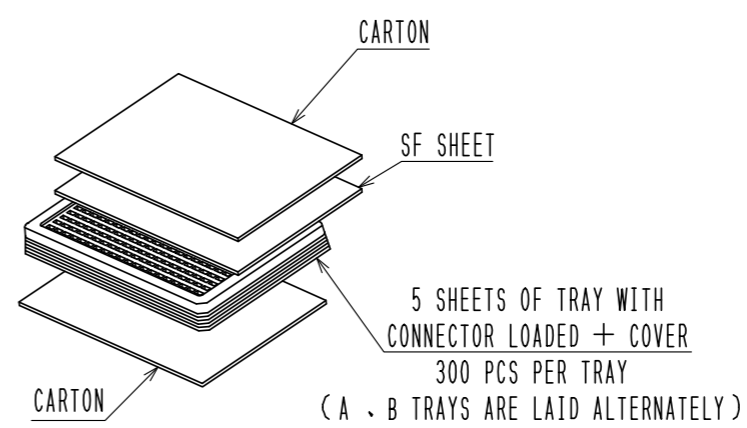

3. STORE 2 UNITS OF BANDED TRAY INTO A CARTON BOX (K-1)  
 (STORE A BOUNDARY PLATE ON TOP OF THE SURFACE, THEN CLOSE  
 THE BOX BY STICKING GUMMED TAPE)

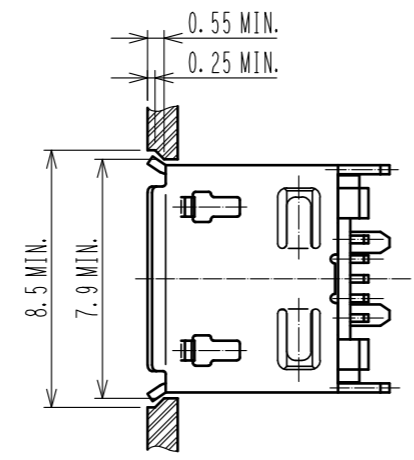
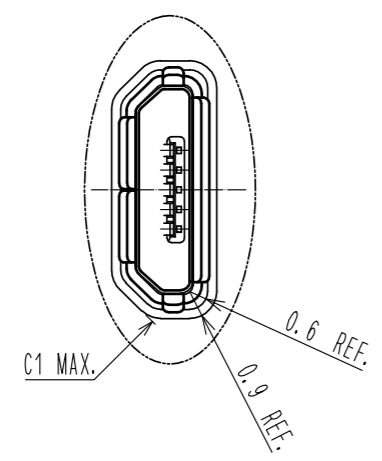
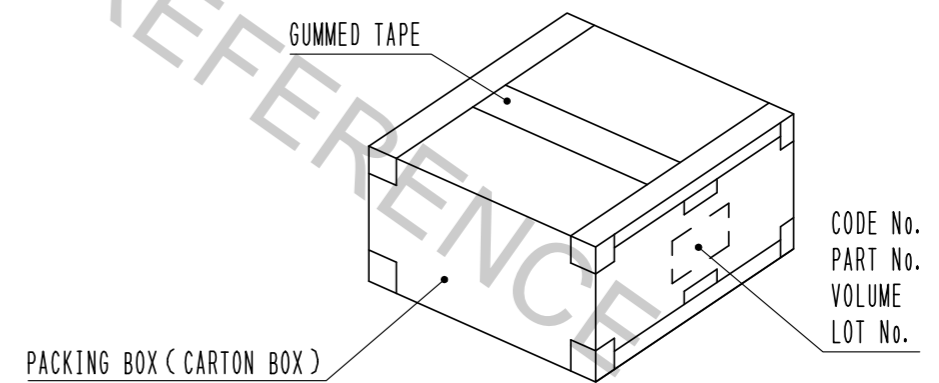

MATED WITH CORRESPONDING PLUG(4:1)

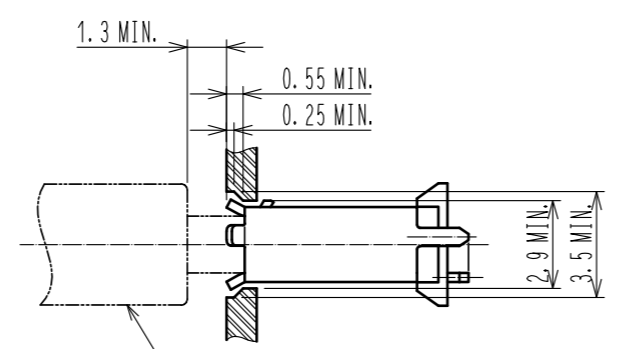

OUTLINE OF THE B KEY PLUG OF  
 HIROSE'S MICRO USB 'ZX SERIES'

<b>HRS</b>	DRAWING NO.	EDC-126723-30-00	
	PART NO.	ZX80-B-5P(30)	
	CODE NO.	CL242-0051-0-30	