

PART NUMBER	GRNDBAR 1 POS	GRNDBAR 2 POS	GRNDBAR 3 POS	GRNDBAR 4 POS	GRNDBAR 5 POS	GRNDBAR 6 POS	GRNDBAR 7 POS	GRNDBAR 8 POS	GRNDBAR 9 POS	GRNDBAR 10 POS	GRNDBAR 11 POS	GRNDBAR 12 POS
10127156-101LF	25A,24B,25C,24D,25E	22A,23B,22C,23D,22E	21A,20B,21C,20D,21E	18A,19B,18C,19D,18E	17A,16B,17C,16D,17E	14A,15B,14C,15D,14E	13A,12B,13C,12D,13E	10A,11B,10C,11D,10E	9A,8B,9C,8D,9E	6A,7B,6C,7D,6E	5A,4B,5C,4D,5E	2A,3B,2C,3D,2E

ABOVE TABLE SHOWS CONNECTED GROUND POSITIONS OF INDIVIDUAL GROUND BARS

PINNING CONFIGURATION

F	G	G	G	G	G	G	G	G	G	G		G	G	G	G	G	G	G	G	G	G	G
E	G	G	HS	HS	G	G	HS	HS	G	G	HS	HS	G	G	HS	HS	G	G	HS	HS	G	G
D	HS	HS	G	G	HS	HS	G	G	HS	HS	G	G	HS	HS	G	G	HS	HS	G	G	HS	HS
C	G	G	HS	HS	G	G	HS	HS	G	G	HS	HS	G	G	HS	HS	G	G	HS	HS	G	G
B	HS	HS	G	G	HS	HS	G	G	HS	HS	G	G	HS	HS	G	G	HS	HS	G	G	HS	HS
A	G	G	HS	HS	G	G	HS	HS	G	G	HS	HS	G	G	HS	HS	G	G	HS	HS	G	G
Z	0	0	0	0	0	0	0	0	0	0		0	0	0	0	0	0	0	0	0	0	0
	01										11											25

HS	HIGH SPEED SIGNAL
LS	LOW SPEED SIGNAL
G	GROUND
0	EMPTY

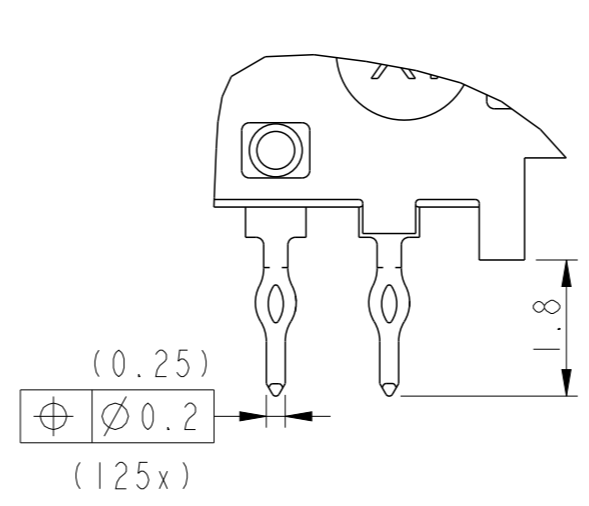
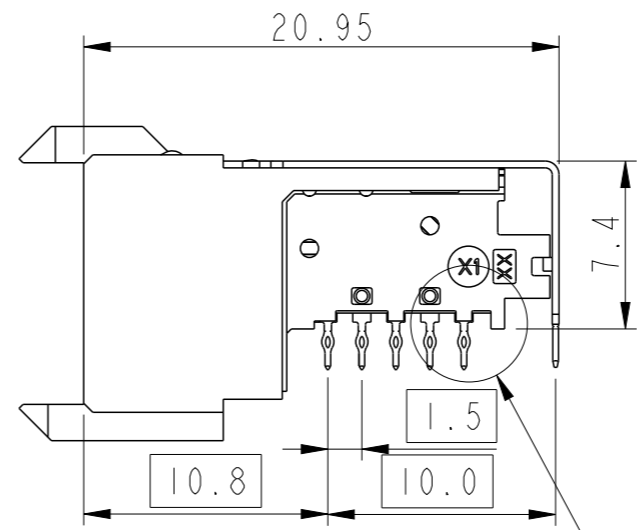
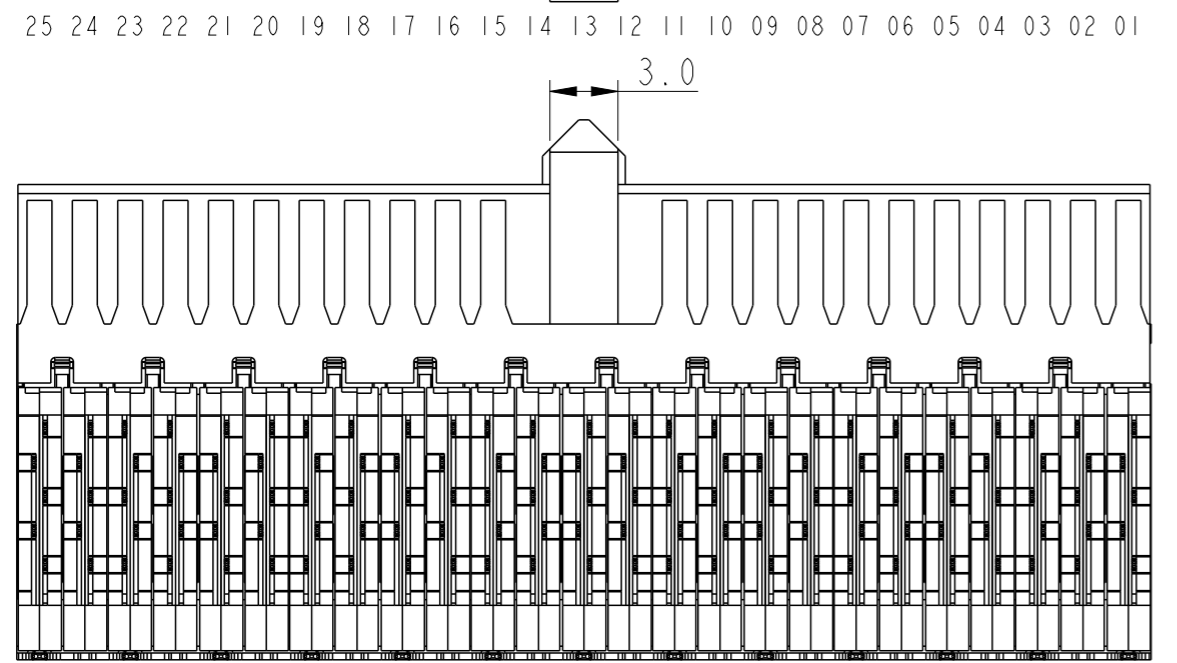
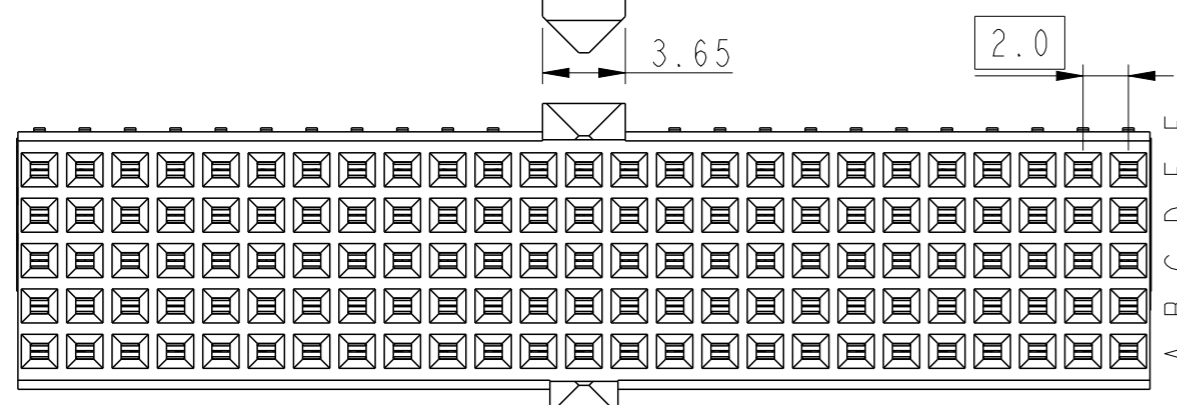
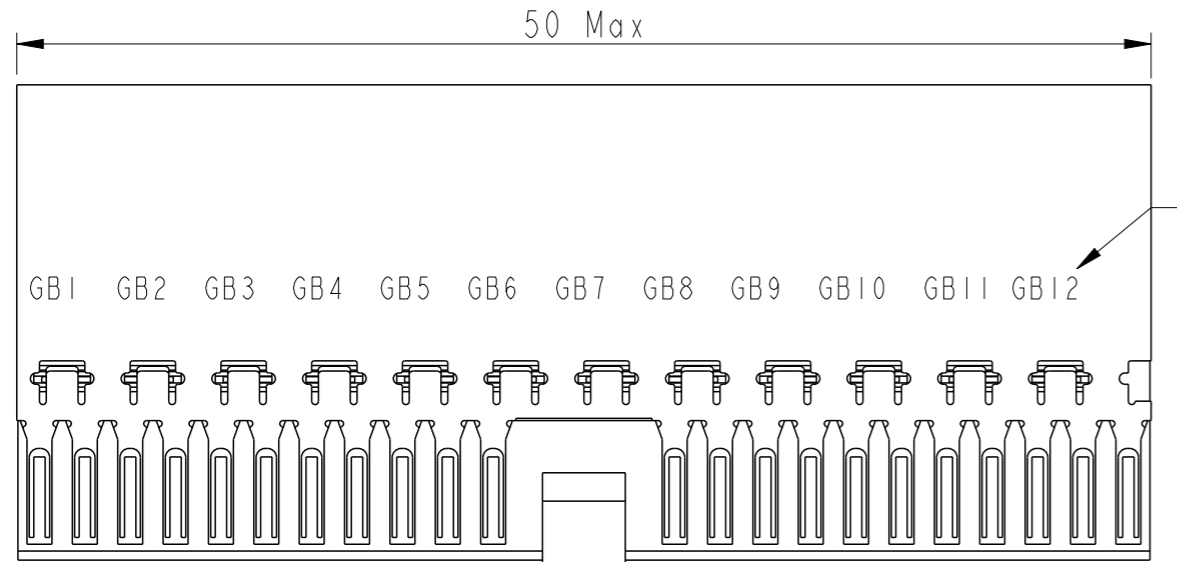

SEE DETAIL A

DETAIL A
SCALE 10:1

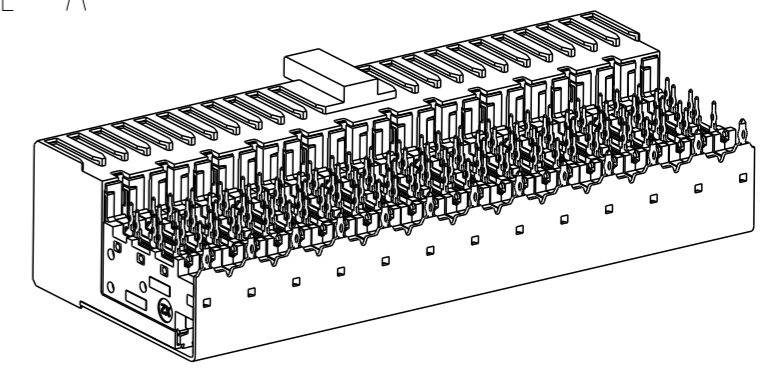
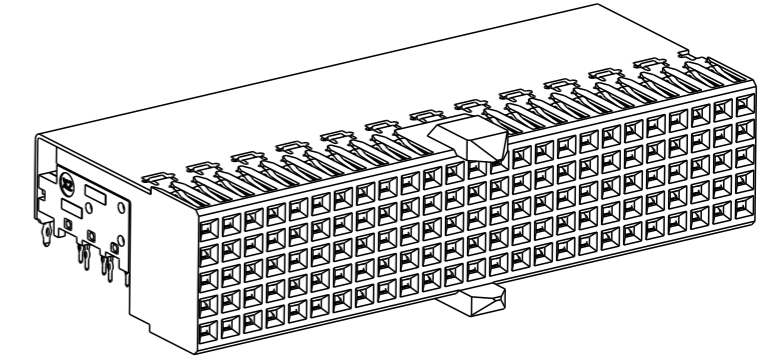

spec ref	-	dr	Arjun K-A	2016/02/13	projection	MM	size	A3	scale	2:1
tolerance std	ISO 406 ISO 1101	eng	Binesh C	2018/06/21			ecn no	ELX-I-30401-1	rel level	Released
TOLERANCES UNLESS OTHERWISE SPECIFIED		chr	-	product family						
surface	linear	0.X	±0.30		TYPE-AB RECEPTACLE ASSEMBLY		dwg no	10127156	rev	B
		0.XX	±0.20		MILLIPACS HIGH SPEED					
	angular	0°	±3°		cat. no.	10127156-101LF				

