

PART NAME: KNOB SCALE: 1:1 DATE: 12/6/16 DR. BY JAM

DAVIES MOLDING COMPANY
CAROL STREAM, ILLINOIS 60188

P/N 1400DR
BASE PART 1400-38
INSERT I2083 (SPRING)

THIS DRAWING IS THE PROPERTY OF DAVIES MOLDING COMPANY, IS SUBMITTED SOLELY AS A DESIGN OR ENGINEERING PROJECT. WE ACCEPT NO RESPONSIBILITY WHATSOEVER FOR THE PRACTICAL APPLICATION OF THE PIECES MADE TO THIS DESIGN.

SCALE 2 : 1

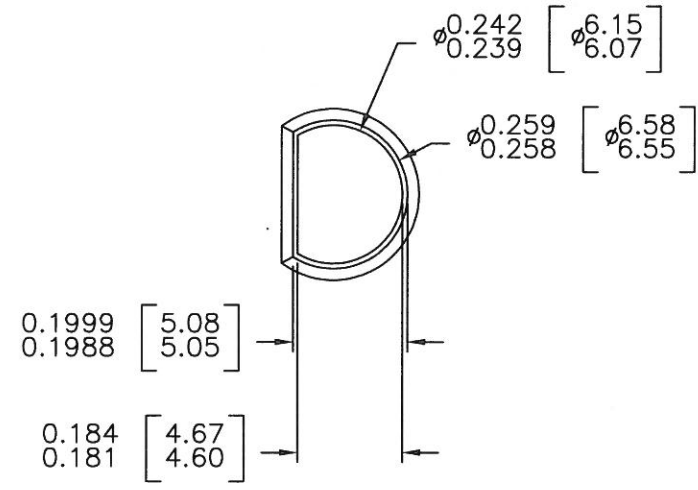
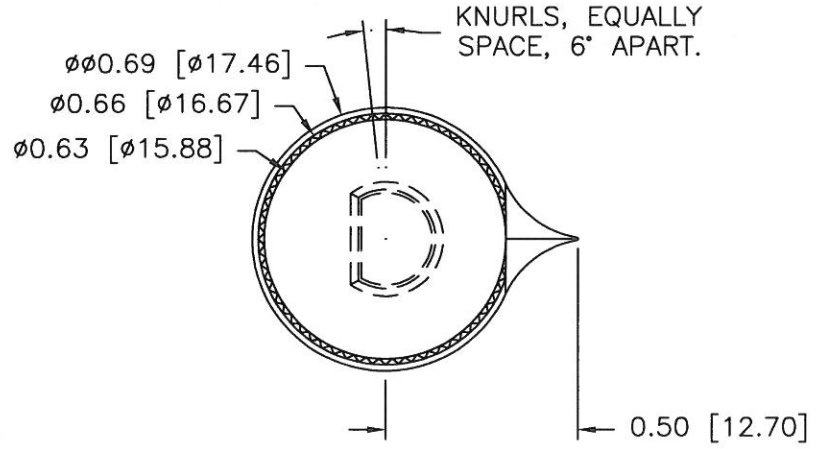

SCALE 3:1
MOLDED HOLE DETAIL

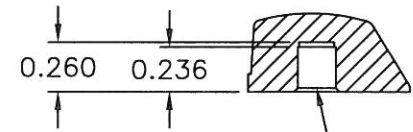
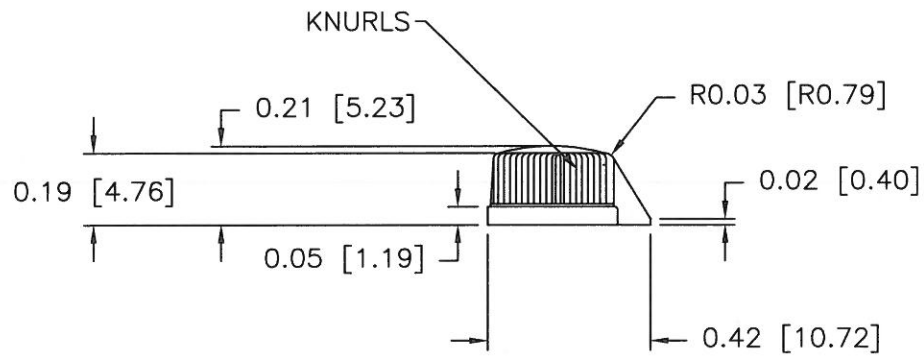

SPRING I2083 TO ACCOMMODATE
 $\phi 6$ MM SHAFT FLATTED TO 4.5MM

SECTION A-A

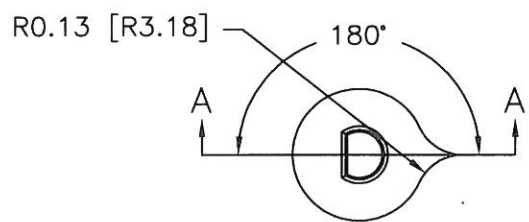

MATERIAL: G.P. PHENOLIC (B11)
COLOR: BLACK

TOLERANCES: UNLESS OTHERWISE SPECIFIED	DO NOT SCALE DRAWING			
DECIMALS: X.XXX ± .005 X.XX ± .015	MM: X.XX ± 0.15MM X.X ± 0.4MM			
FRACTIONS ± 1/64	ANG. ± 1°	-	WAS SK1400-26	JAM 12/6/16
CHANGES				