

PART NAME: KNOB SCALE: 1:1 DATE: 8/14/13 DR. BY: JAM

THIS DRAWING IS THE PROPERTY OF DAVIES MOLDING COMPANY, IS SUBMITTED SOLELY AS A DESIGN OR ENGINEERING PROJECT. WE ACCEPT NO RESPONSIBILITY WHATSOEVER FOR THE PRACTICAL APPLICATION OF THE PIECES MADE TO THIS DESIGN.

DAVIES MOLDING DESIGNERS & MANUFACTURERS OF F.K. NOBS, HANDLES, CASES & CUSTOM PLASTIC COMPONENTS

P/N	1227-L
MOLD #	1227
CAVITY	1227
CORE	1227
PIN	1227-L

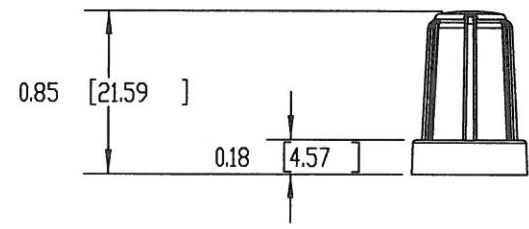
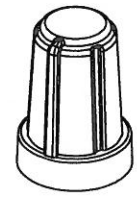
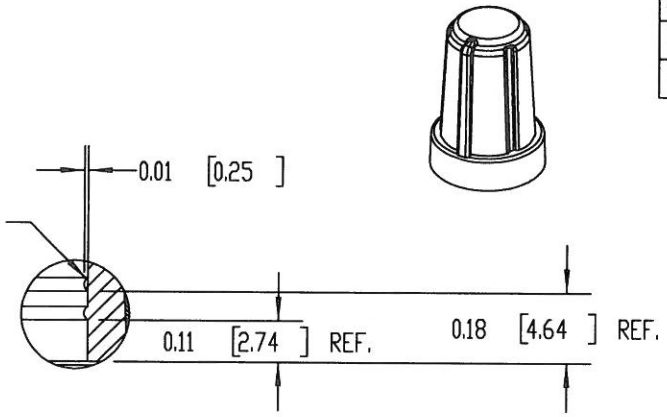
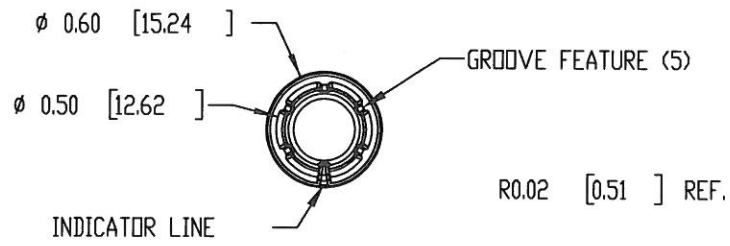

DETAIL A
SCALE 2:1

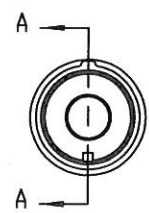
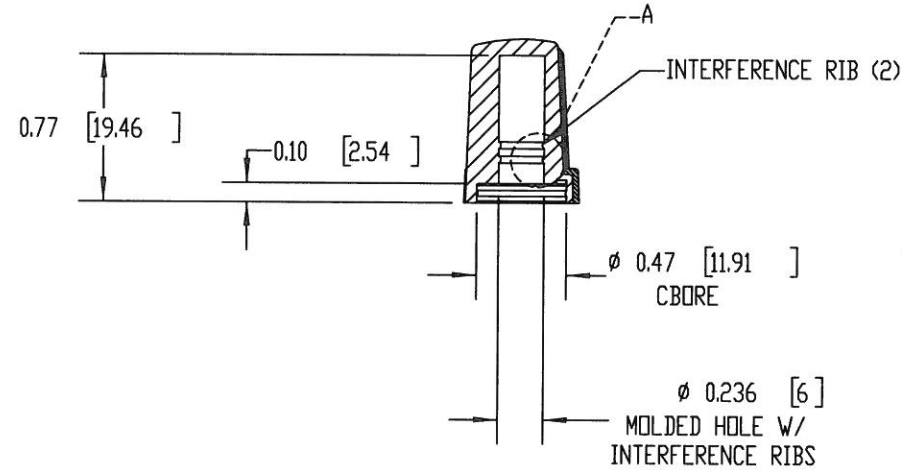

SECTION A-A

SUBSTRATE MATERIAL: POLYPROPYLENE (CLD)
 COLOR: WHITE (PC23083)
 OVERMOLD MATERIAL: TPE (TPE3)
 COLOR: BLACK

TOLERANCES: UNLESS OTHERWISE SPECIFIED	DO NOT SCALE DRAWING			
DECIMALS: X.XXX ± .005 X.XX ± .015	MM: X.XX ± 0.15MM X.X ± 0.4MM			
FRACTIONS ± 1/64	ANG. ± 1°	CHANGES		