

REVISIONS					
REV	ECO	DESCRIPTION	DATE	BY	APPR
A1	-	RELEASE NEW DRAWING	17/OCT/18	BROOK	TOMMY
A2	-	ADD MORE MATERIAL NOTES	24/OCT/18	BROOK	TOMMY

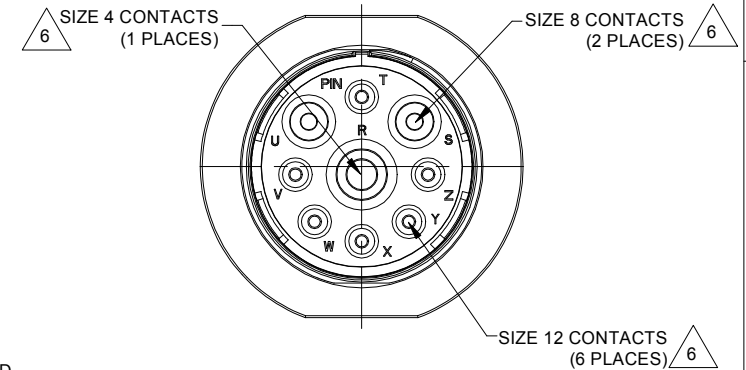
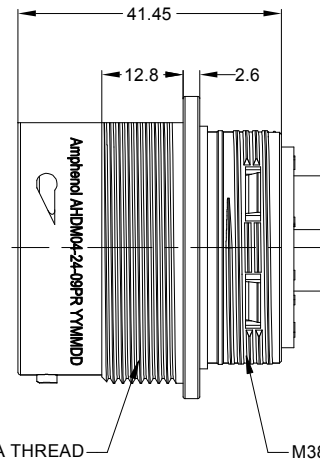
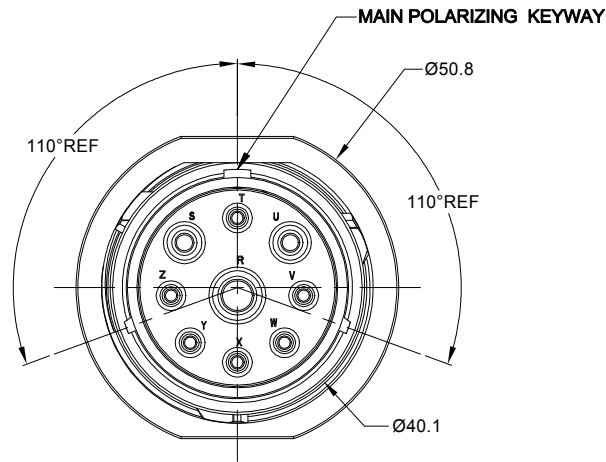

NOTES: UNLESS OTHERWISE SPECIFIED

- MATERIAL:**
SHELL: ZINC ALLOY, NICKEL PLATED
INSERT AND RETAINING RING: THERMOPLASTIC
SEAL: SILICONE RUBBER
- MODIFICATIONS:** THREADED HOUSING; REDUCED DIA. SEAL
- SPECIFICATIONS:**
 - OPERATING TEMPERATURE: -55°C TO +125°C.
 - DIELECTRIC WITHSTANDING VOLTAGE: LESS THAN 2 MILLIAMPS CURRENT LEAKAGE @ 1500 VOLTS AC.
 - INSULATION RESISTANCE: 1000 MEGOHM MIN @ 25°C.
 - MOISTURE RESISTANCE: IP67&IP69K (MATED CONDITION).
 - MATING CYCLE DURABILITY: 100 CYCLES
 - RoHS COMPLIANT
- MATING PART:** AHDM06-24-09S* (* = SEAL TYPE)
- ALL DIMENSIONS ARE FOR REFERENCE USE ONLY.**

CONTACT SIZE AND WIRE RANGE:

CONTACT SIZE	MIN. INSUL O.D.	MAX. INSUL O.D.	TYPICAL WIRE RANGE	CURRENT RATING
4	6.63 mm (.261 in)	7.42 mm (.292 in)	6 AWG	100 AMPS
8	3.43 mm (.135 in)	5.59 mm (.220 in)	8-10 AWG	60 AMPS
12	2.46 mm (.097 in)	4.01 mm (.158 in)	10-14 AWG	25 AMPS

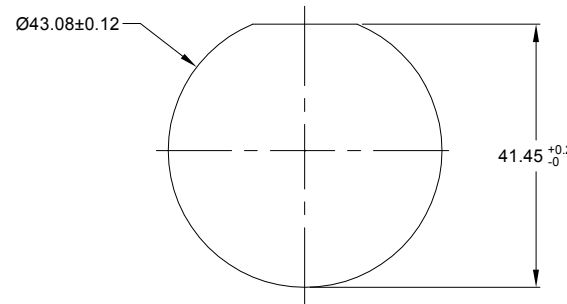

RECOMMENDED PANEL MOUNTING HOLE
RECOMMENDED PANEL THICKNESS: 1.6 TO 4.7MM

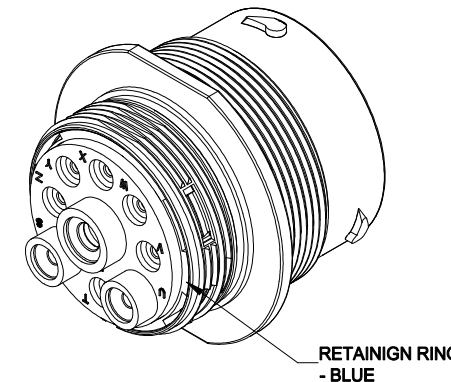

AHDM04-24-09PR		DESCRIPTION		ITEM
QUANTITY	PART NUMBER	MATERIALS LIST		
UNLESS OTHERWISE SPECIFIED				
1) All dimensions are in metric (mm).				
2) Tolerances are as follows:				
1 PL DEC ±0.30 Fractions ±1/64				
2 PL DEC ±0.15 Angles ±1°				
3) Note reference =				
SIGNATURES		DATE		
DRAWN: BROOK		24/OCT/18		
CHECKED: ORION		24/OCT/18		
ENGINEER:				
APPROVAL: TOMMY		24/OCT/18		
MATERIAL SPECIFICATIONS:		CUSTOMER:		
PROCESS SPECIFICATIONS:		THIS DRAWING IS SUPPLIED FOR INFORMATION ONLY. DESIGN FEATURES, SPECIFICATIONS AND PERFORMANCE DATA SHOWN HEREON ARE THE PROPERTY OF THE AMPHENOL CORPORATION. NO RIGHTS OF REPRODUCTION ARE IMPLIED. ALL DIMENSIONS ARE SUBJECT TO NORMAL MANUFACTURING VARIATIONS.		
NEXT ASSY:		SIZE B C- TYPE AHD M04-24-09PR REVISION A2		
		SCALE NONE SHEET 1 OF 1		

TITLE: RECPT, 24 SZ 09 PIN, RD, WIDE THD
DWG NO: AHDM04-24-09PR
REV: A2
SH: 1
OF: 1