

REVISIONS					
REV	ECO	DESCRIPTION	DATE	BY	APPR
A1	-	RELEASE NEW DRAWING	17/OCT/18	BROOK	TOMMY
A2	-	ADD MORE MATERIAL NOTES	24/OCT/18	ROOKIE	TOMMY

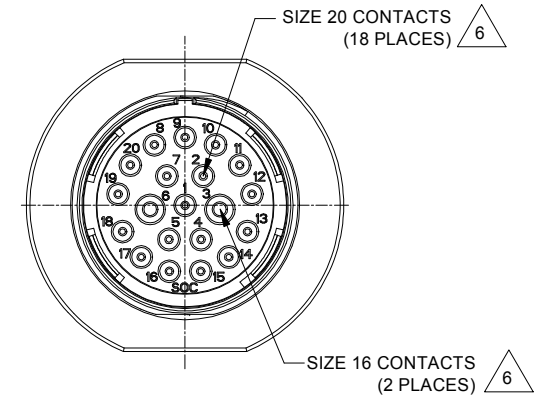

**NOTES: UNLESS OTHERWISE SPECIFIED**

- MATERIAL:**  
SHELL: ZINC ALLOY, NICKEL PLATED  
INSERT AND RETAINING RING: THERMOPLASTIC  
SEAL: SILICONE RUBBER
- MODIFICATIONS:** THREADED HOUSING; NORMAL DIA. SEAL
- SPECIFICATIONS:**
  - OPERATING TEMPERATURE: -55°C TO +125°C.
  - DIELECTRIC WITHSTANDING VOLTAGE: LESS THAN 2 MILLIAMPS CURRENT LEAKAGE @ 1500 VOLTS AC.
  - INSULATION RESISTANCE: 1000 MEGOHM MIN @ 25°C.
  - MOISTURE RESISTANCE: IP67&IP69K ( MATED CONDITION ).
  - MATING CYCLE DURABILITY: 100 CYCLES
  - RoHS COMPLIANT
- MATING PART:** AHDM06-18-20P\* (\* = SEAL TYPE)
- ALL DIMENSIONS ARE FOR REFERENCE USE ONLY.**

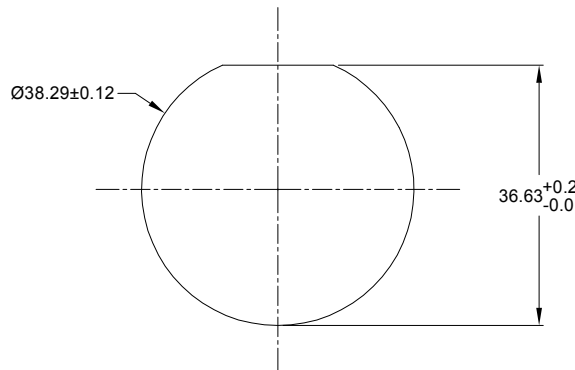

RECOMMENDED PANEL MOUNTING HOLE  
RECOMMENDED PANEL THICKNESS: 1.6 TO 4.7MM

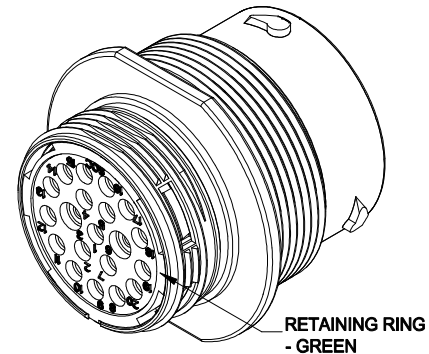

**CONTACT SIZE AND WIRE RANGE:**

CONTACT SIZE	MIN. INSUL O.D.	MAX. INSUL O.D.	TYPICAL WIRE RANGE	CURRENT RATING
20	1.02 mm (.040 in)	2.41 mm (.095 in)	16-22 AWG	7.5 AMPS
16	2.54 mm (.100 in)	3.40 mm (.134 in)	14-20 AWG	13 AMPS

AHDM04-18-20SN		DESCRIPTION		ITEM
QUANTITY	PART NUMBER	MATERIALS LIST		
<b>UNLESS OTHERWISE SPECIFIED</b> 1) All dimensions are in metric (mm). 2) Tolerances are as follows: 1 PL DEC ±0.30 Fractions ±1/64 2 PL DEC ±0.15 Angles ±1° 3 PL DEC ±0.08				
SIGNATURES		DATE		
DRAWN: ROOKIE		24/OCT/18		
CHECKED: ORION		24/OCT/18		
ENGINEER:				
APPROVAL: TOMMY		24/OCT/18		
MATERIAL SPECIFICATIONS:		CUSTOMER:		
PROCESS SPECIFICATIONS:		THIS DRAWING IS SUPPLIED FOR INFORMATION ONLY. DESIGN FEATURES, SPECIFICATIONS AND PERFORMANCE DATA SHOWN HEREON ARE THE PROPERTY OF THE AMPHENOL CORPORATION. NO RIGHTS OF REPRODUCTION ARE IMPLIED. ALL DIMENSIONS ARE SUBJECT TO NORMAL MANUFACTURING VARIATIONS.		
NEXT ASSY:		SCALE: NONE		
<b>Amphenol</b> Sine Systems - www.amphenol-sine.com 44724 Morley Drive Clinton Township, MI 48036				REVISION <b>A2</b>
RECPT, 18 SZ 20 SOC, N, WIDE THD				SIZE <b>B C-</b>
DWG NO: <b>AHDM04-18-20SN</b>				SHEET 1 OF 1

TITLE: RECPT, 18 SZ 20 SOC, N, WIDE THD  
DWG NO: AHDM04-18-20SN  
REV: A2  
SH: 1  
OF: 1