

DEBUR AND BREAK SHARP EDGES

DO NOT SCALE DRAWING

REVISION

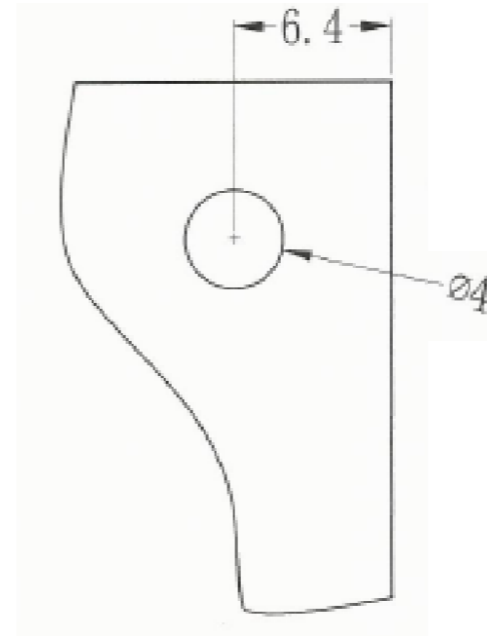
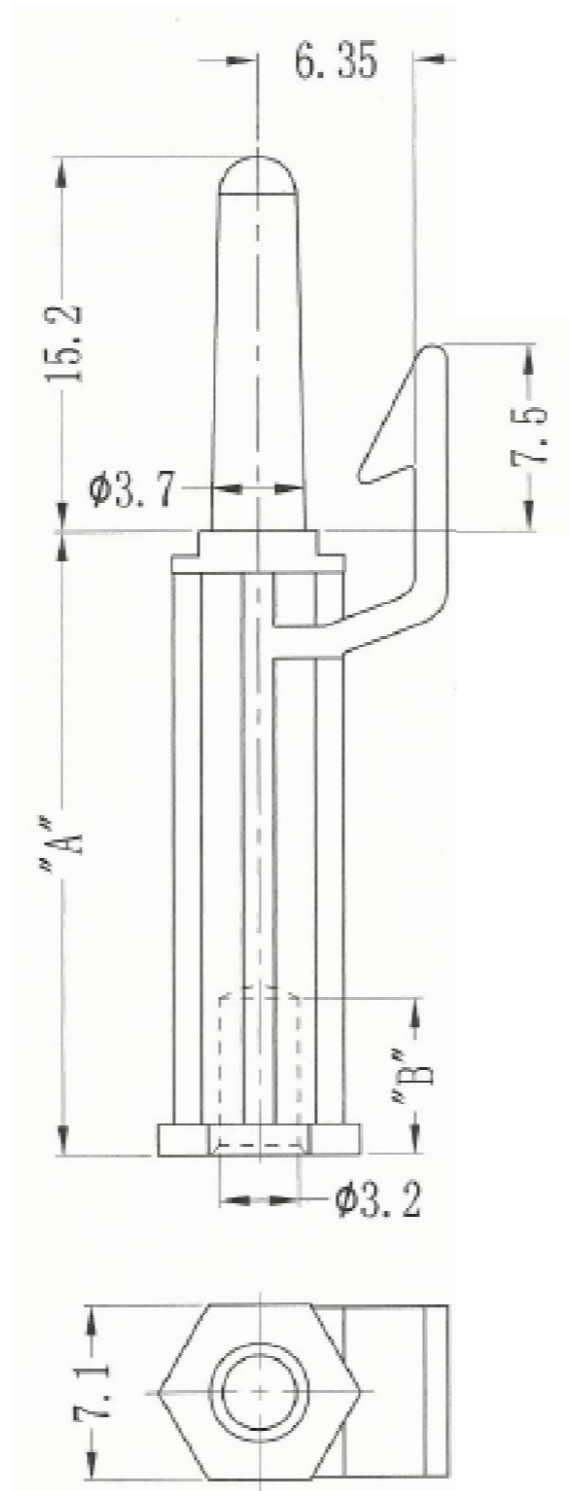

PART No.	"A"	"B"
TRTEHCBS-4-01	6.4	5.2
TRTEHCBS-5-01	7.9	
TRTEHCBS-6-01	9.5	6.4
TRTEHCBS-8-01	12.7	
TRTEHCBS-10-01	15.9	
TRTEHCBS-12-01	19.1	
TRTEHCBS-14-01	22.2	
TRTEHCBS-16-01	25.4	

NOTES

1) MATERIAL - PA66 UL94 V2 - NATURAL - RoHS COMPLIANT



DESIGN RIGHT. TR FASTENINGS LTD, 2003
 UNDER NO CIRCUMSTANCES MUST THIS
 DRAWING BE COPIED OR DISCLOSED,
 WITHOUT FIRST OBTAINING WRITTEN
 AUTHORITY.

UNLESS OTHERWISE SPECIFIED:
 DIMENSIONS ARE IN MILLIMETERS
 SURFACE FINISH:
 TOLERANCES:

ISO 2768 m	NAME	DATE
	DRAWN MARTIN ELLIOTT	16/07/14
	CHK'D	
	APPV'D	

CUSTOMER PART No

MATERIAL:

SEE NOTES

HEAT TREATMENT

N/A

FINISH:

N/A

TITLE:

EDGE HOLDING CIRCUIT
 BOARD SUPPORT

DWG NO.

TRTEHCBS-XX-01

A3

PROJECTION

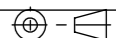

SHEET 1 OF 1