

13 - 13.1

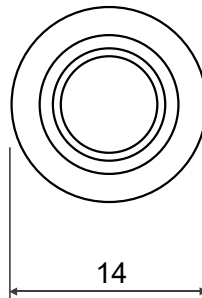
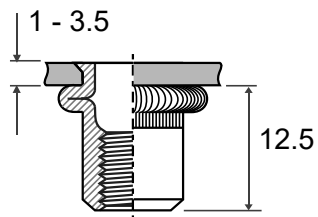

Approximate Performance in Laboratory Tests

Tensile Strength: 32000 N

Direct Torque: 32 Nm

Body Torque: 8.5 Nm

Shear Strength: 5000 N

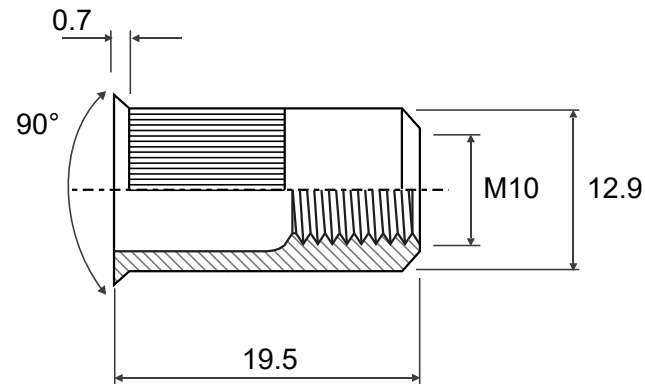

	Material		Customer Part No.	
	Finish		Web Ref No	