

REVISIONS					
REV	ECO	DESCRIPTION	DATE	BY	APPR
A1	--	FIRST RELEASED	Jun-14-2018	Blink	Tommy

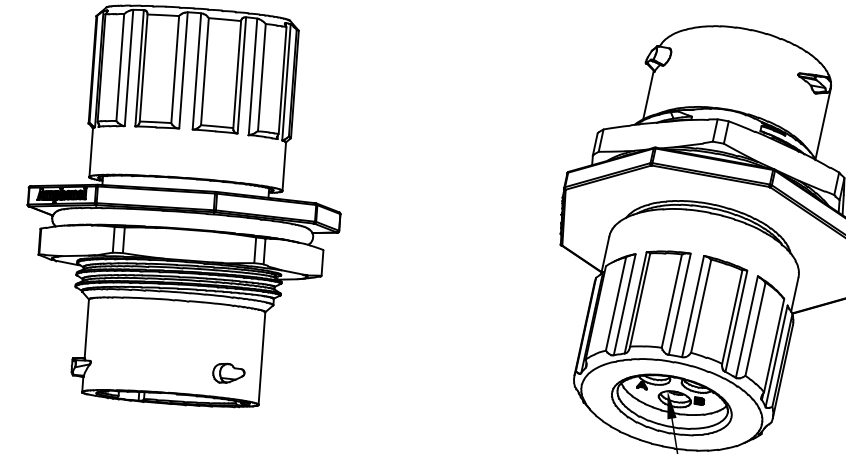
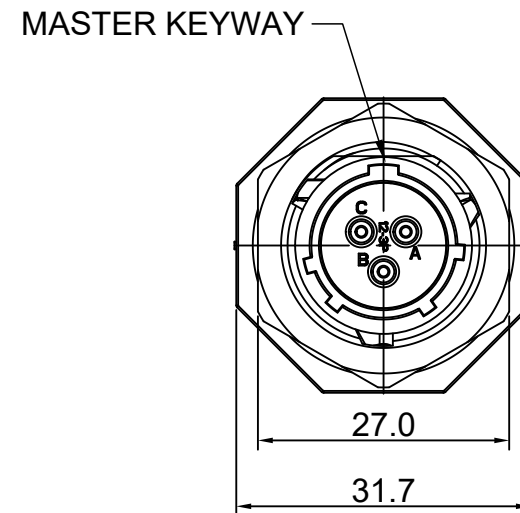
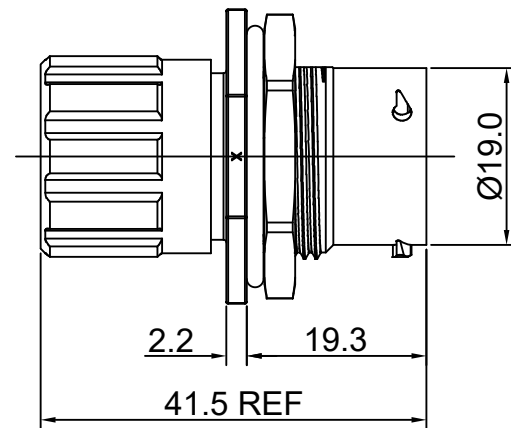

SEALING PLUGS CAN BE PURCHASED SEPARATELY

NOTES: (UNLESS OTHERWISE SPECIFIED)

1. MATERIAL:

- SHELL: THERMOPLASTIC, UL94 V-0.
- INSERT: THERMOPLASTIC, UL94 V-0.
- O-RING: NBR OR SILICONE RUBBER.
- SEAL GASKET: NBR OR SILICONE RUBBER.
- END CAP: THERMOPLASTIC, UL94 V-0.
- PLASTIC RING: THERMOPLASTIC, UL94 V-0.
- WIRE SEAL: SILICONE RUBBER.

2. SPECIFICATIONS:

- 2.1 RATED CURRENT: 13A (MAX).
- 2.2 RATED VOLTAGE: 600V(AC/DC).
- 2.3, OPERATING TEMPERATURE: SEE TABLE.
- 2.4, DIELECTRIC WITHSTANDING VOLTAGE: LESS THAN 2 MILLIAMPS CURRENT LEAKAGE@2500 VOLTS AC.
- 2.5, INSULATION RESISTANCE: 5000 MEGOHMS MIN.
- 2.6, IP-CLASS: IP67 AND IP69K IN THE MATED CONDITION, WIRE SEALS FULLY POPULATED.
- 2.7, MATING CYCLES DURABILITY: 500 CYCLES MIN.
- 2.8, RoHS COMPLIANT.

3. SUITABLE CONTACTS : 16# CONTACT.

4. ALL DIMENSIONS ARE FOR REFERENCE USE ONLY.

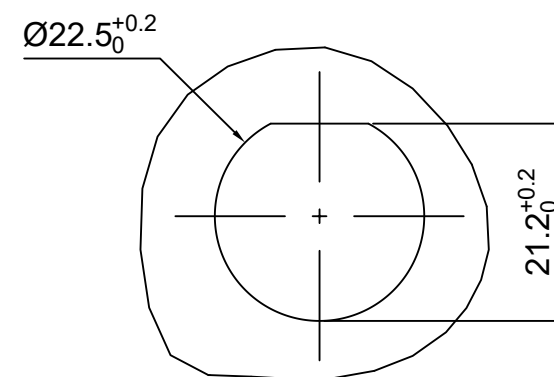

PANEL CUT OUT REFERENCE

KEY	PART NUMBER	
		-40°C ~ 105°C
N	RTS712N3PHEC	RTS712N3PHEC03

QUANTITY	PART NUMBER	DESCRIPTION	ITEM
<b>MATERIALS LIST</b>			
UNLESS OTHERWISE SPECIFIED 1) All dimensions are in metric(mm). 2) Tolerances are as follows: 1 PL DEC ±0.30 2 PL DEC ±0.15 3 PL DEC ±0.08 3) Note reference =		SIGNATURES DRAWN: Blink CHECKED: Tod ENGINEER: APPROVAL: Tommy	DATE Jun-14-2018 Jun-14-2018 Jun-14-2018
MATERIAL SPECIFICATIONS:		<b>Amphenol</b> Sine Systems - www.amphenol-sine.com 44724 Morley Drive Clinton Township, MI 48036	
PROCESS SPECIFICATIONS:		ECO-MATE, RECEPTACLE, END CAP, JAM NUT, SIZE 12, 3 POS, PIN	
NEXT ASSY:		THIS DRAWING IS SUPPLIED FOR INFORMATION ONLY. DESIGN FEATURES, SPECIFICATIONS AND PERFORMANCE DATA SHOWN HEREON ARE THE PROPERTY OF THE AMPHENOL CORPORATION. NO RIGHTS OF REPRODUCTION ARE IMPLIED. ALL DIMENSIONS ARE SUBJECT TO NORMAL MANUFACTURING VARIATIONS.	SIZE: B C- TYPE: NONE DWG NO: RTS712*3PHECxx REVISION: A1
		SCALE: NONE	SHEET 1 OF 1

TITLE: ECO-MATE RECEPTACLE END CAP JAM NUT SIZE 12 3 POS PIN  
DWG NO: RTS712\*3PHECxx  
REV: A1  
SH: 1  
OF: 1