

CLIFF

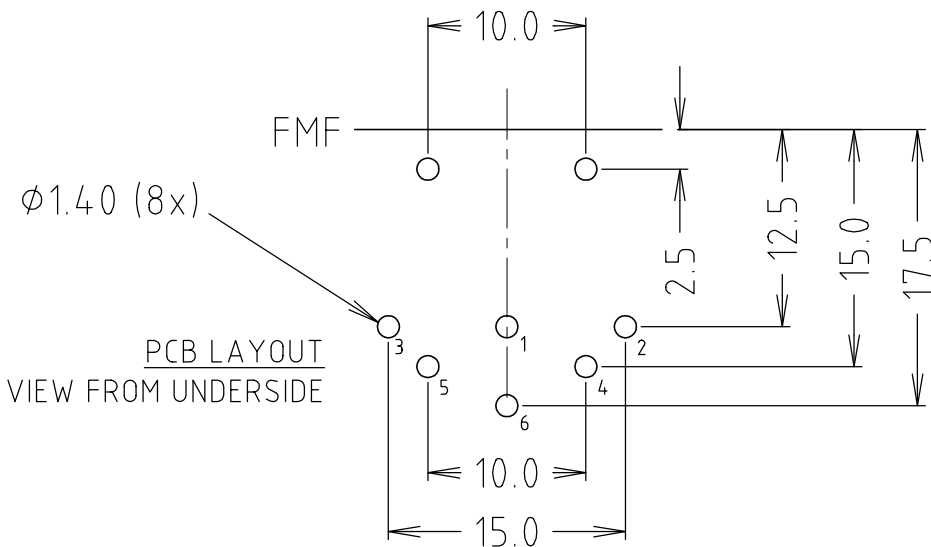
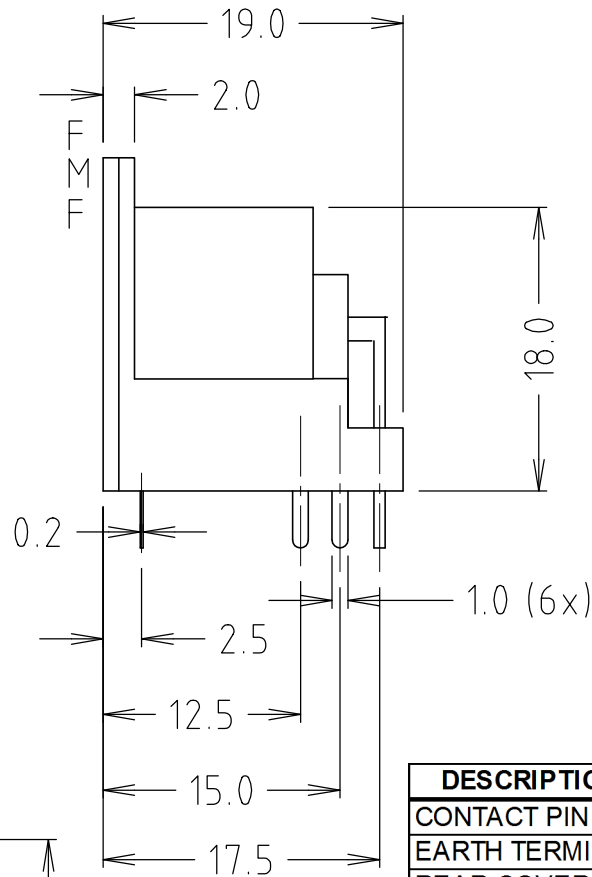
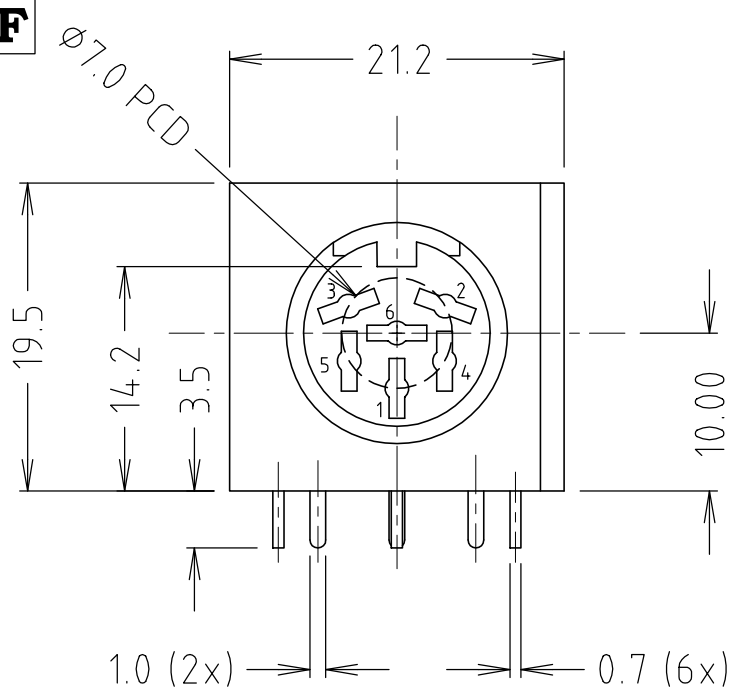

ISS.	AMEND	DATE
1	ISSUED	18/06/09
2	MATERIAL TABLE ADD	20/07/12

DESCRIPTION	MATERIAL	FINISH	QTY
CONTACT PIN	BRASS	SILVER PLATE	6
EARTH TERMINAL	PHOSPHOR BRONZE	SILVER PLATE	1
REAR COVER	PBT 30%GF	BLACK	1
HOUSING	PBT 30%GF	BLACK	1

SPECIFICATION

- CURRENT RATING: 100VAC 1A max
12VDC 2A max
- CONTACT RESISTANCE (INITIAL): 30mΩ max @AC100mA(max) 1KHz
- INSULATION RESISTANCE (INITIAL): 100MΩ (MIN) @500V DC
- WITHSTAND VOLTAGE: 500VAC 60HZ FOR 1 MINUTE
- INSERTION FORCE (INITIAL): 4.5Kg max
- WITHDRAWAL FORCE: 0.9-3.0Kg
- LIFE TEST: 5000 CYCLES MIN. AFTER TESTING CONTACT RESISTANCE SHALL NOT EXCEED 100mΩ
- RoHS COMPLIANT

RoHS
COMPLIANT

TOLERANCE
NO DEC. PLACE ±
1 DEC. PLACE ±
2 DEC. PLACE ±
HOLE Ø ±
ANGLES ±
UNLESS OTHERWISE STATED

Cliff Electronic Components Ltd.

76 Holmehorpe Avenue, Holmehorpe Industrial Estate,
Redhill, Surrey, RH1 2PF, England, UK
Tel: 01737-771375 Fax: 01737-766012 Website: www.cliffuk.co.uk

DIMENSIONS IN MILLIMETERS UNLESS OTHERWISE STATED. WORK TO DIMENSIONS. REMOVE ALL BURRS. IF IN DOUBT ASK.

3rd ANGLE PROJECTION:

DO NOT SCALE

MATERIAL: PBT +30% GF - UL94V-0 / COMPOSITE METAL

TITLE: 6 PIN DIN SOCKET 240°

FINISH: AS MOULDED / SILVER PLATED

DRWG. No. **FC680806**

THE CONTENTS OF THIS DOCUMENT MUST NOT BE COPIED OR DISCLOSED TO A 3rd PARTY WITHOUT WRITTEN PERMISSION OF CLIFF UK. © 2009

DRAWN: C.A.M.J.

APPROVED: R.W.T.

FORM: A4DRWGH