

THIS DRAWING IS UNPUBLISHED. RELEASED FOR PUBLICATION 20
 © COPYRIGHT 20 BY - ALL RIGHTS RESERVED.

REVISIONS				
P	LTR	DESCRIPTION	DATE	APVD
5		REVISED	30MAY2018	J. J. W. H.

Ø0.6
PICK AND PLACE AREA

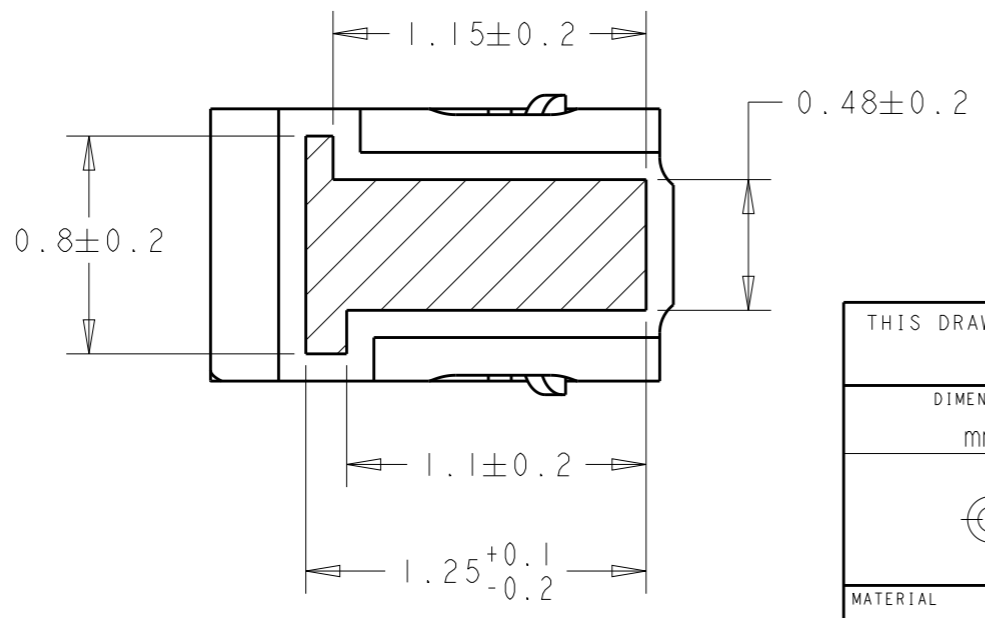
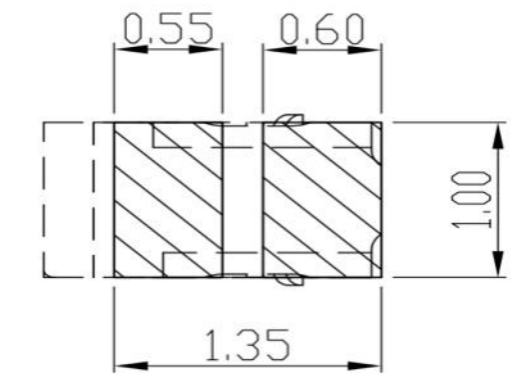
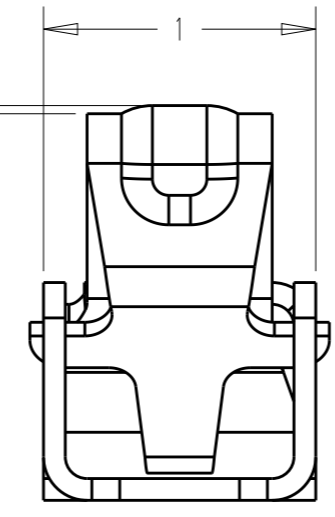
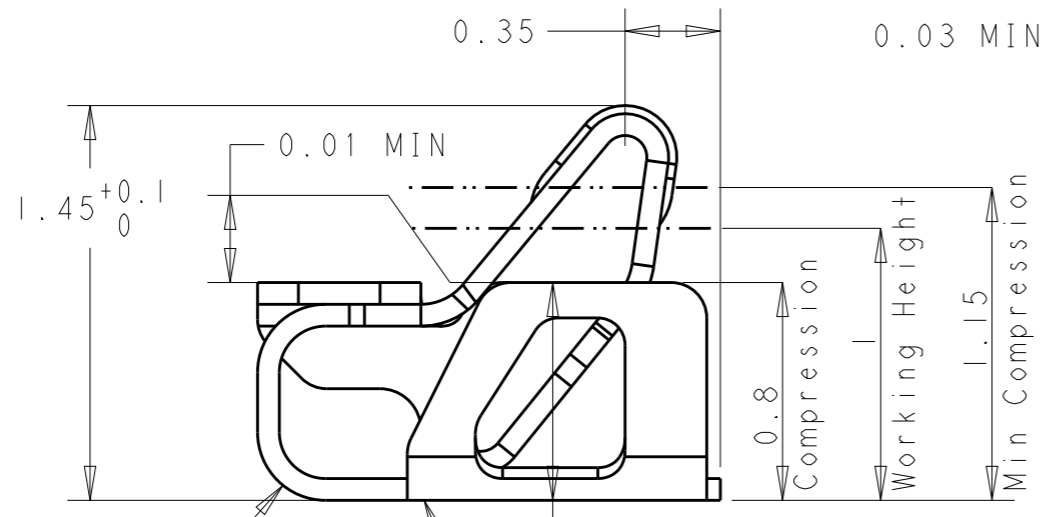
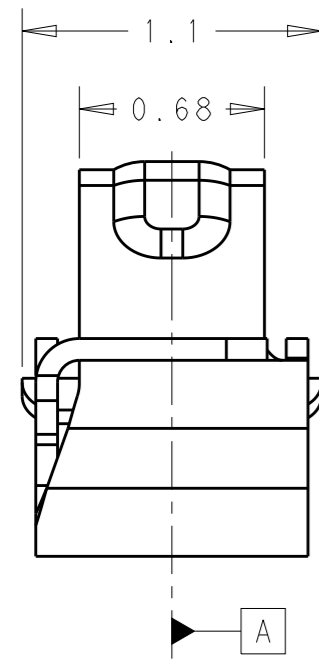
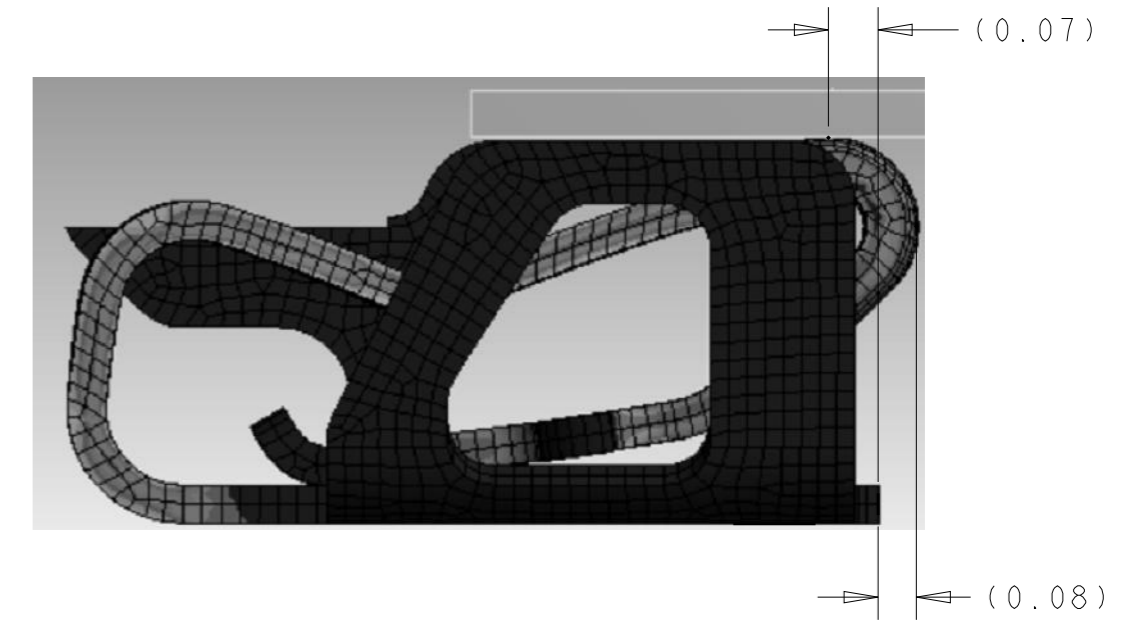
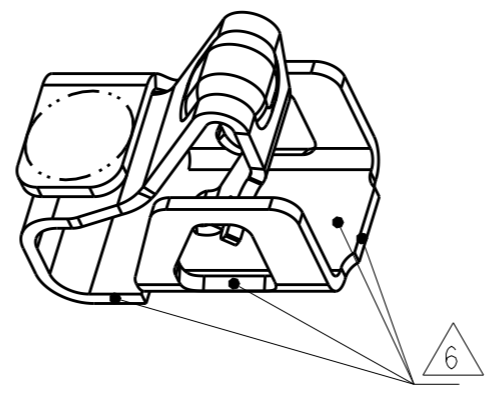
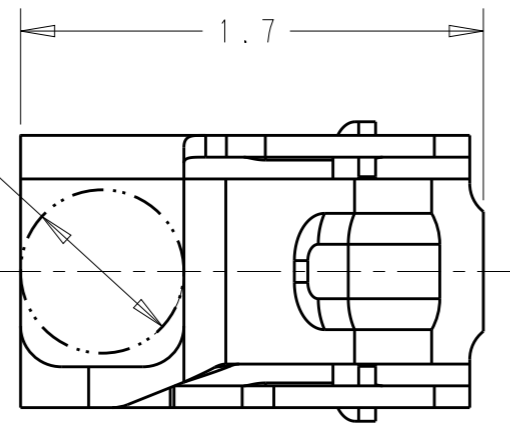

	0.08	BEFORE IR
	0.1	AFTER IR

RECOMMENDED P.C.B LAYOUT TOLERANCE ±0.05

- PART NUMBER: 2336713-1.
- MATERIAL: SUS301 K1500. THICKNESS=0.08mm.
- FINISH : 2.0~7.6um NICKEL UNDERLAYER ALL OVER .
0.25um MIN. GOLD PLATING ON CONTACT AREA.
0.075~0.6um GOLD PLATING ON SOLDER AREA
- NORMAL FORCE: 0.5N MIN(INITIAL) AT WORKING RANGE.
0.4N MIN AFTER 1500CYCLES DURABILITY.
- WORKING RANGE: 0.80mm ~ 1.15 mm
- Ni BARRIER AREA
- RATED CURRENT 1.5A, RATED VOLTAGE 10V DC.
- CONTACT RESISTANCE: 30 milliohm MAX INITIAL.
- OPERATION TEMPERATURE: -40~85 DEGREES.

THIS DRAWING IS A CONTROLLED DOCUMENT.		DWN JONE JI 14MAY2018	TE Connectivity	
		CHK WENKE HE 14MAY2018		
DIMENSIONS: mm		APVD WENKE HF 14MAY2018	NAME SPRING FINGER 1.45H	
TOLERANCES UNLESS OTHERWISE SPECIFIED:		PRODUCT SPEC -	RESTRICTED TO	
<ul style="list-style-type: none"> ±0.1 1 PLC ±0.1 2 PLC ±0.01 3 PLC ±0.001 4 PLC ±0.0001 ANGLES ± 		APPLICATION SPEC -	SIZE A3	CAGE CODE 00779
MATERIAL -		WEIGHT -	DRAWING NO C-2336713	
		CUSTOMER DRAWING	SCALE 36:1	SHEET 1 OF 2
				REV 5

REVISIONS

P	LTR	DESCRIPTION	DATE	DWN	APVD

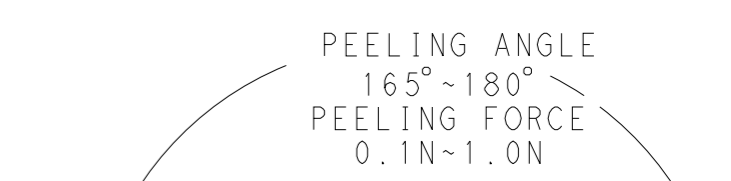
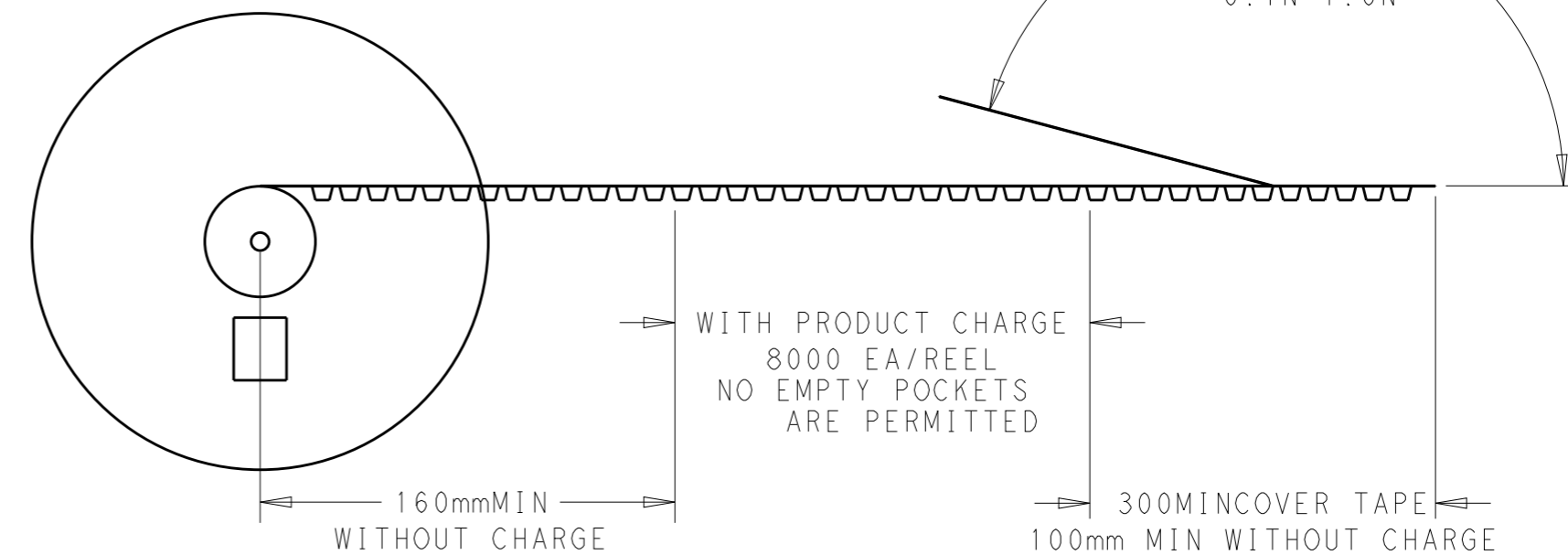
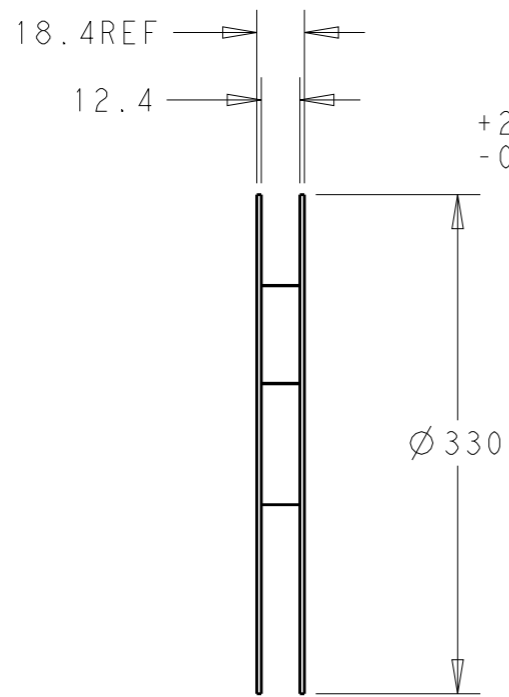

➔ DIRECTION OF TOP OF REEL

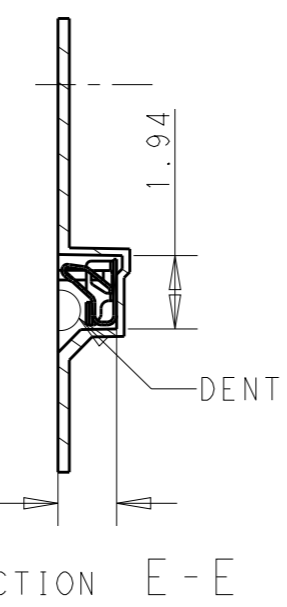
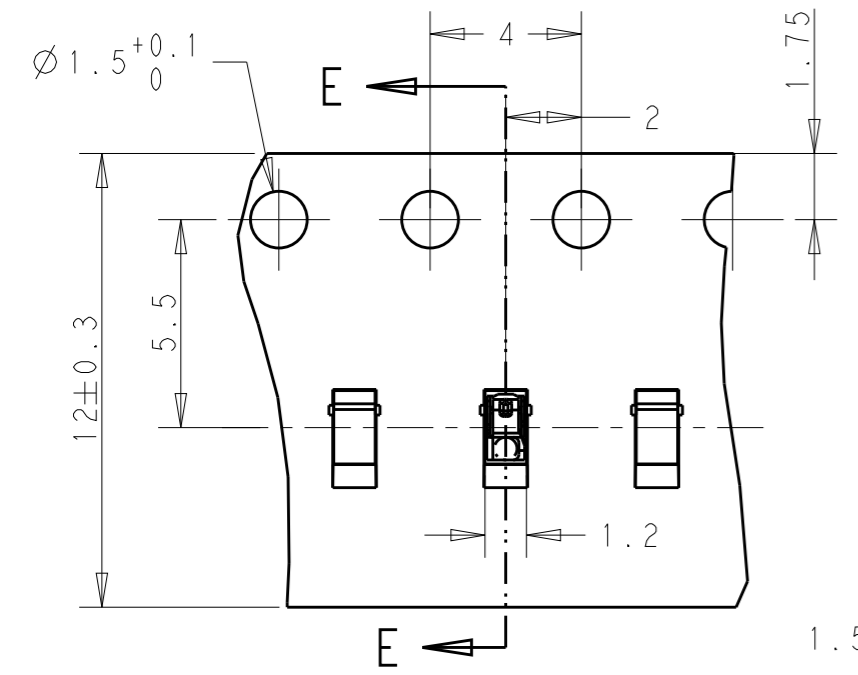

NOTE:
1. PACKAGE SPEC EIA-481-D

THIS PRINT IS
PRELIMINARY
 UNQUALIFIED PRODUCT
 CONTACT PRODUCT ENGINEERING
 BEFORE USING THIS PRINT

THIS DRAWING IS A CONTROLLED DOCUMENT.		DWN JONE JI 14MAY2018	 TE Connectivity	
DIMENSIONS: mm		CHK WENKE HE 14MAY2018		
TOLERANCES UNLESS OTHERWISE SPECIFIED: ± -		APVD WENKE HF 14MAY2018	NAME	
0 PLC ± 1 PLC ±0.1 2 PLC ±0.01 3 PLC ±0.001 4 PLC ±0.0001 ANGLES ±-		PRODUCT SPEC -	SPRING FINGER 1.45H	
MATERIAL -		APPLICATION SPEC -	SIZE A3	CAGE CODE 00779
FINISH -		WEIGHT -	DRAWING NO C-2336713	RESTRICTED TO
-		CUSTOMER DRAWING	SCALE 36:1	SHEET 2 OF 2
-				REV 5