

RECOMMENDED PCB LAYOUT: COMPONENT SIDE

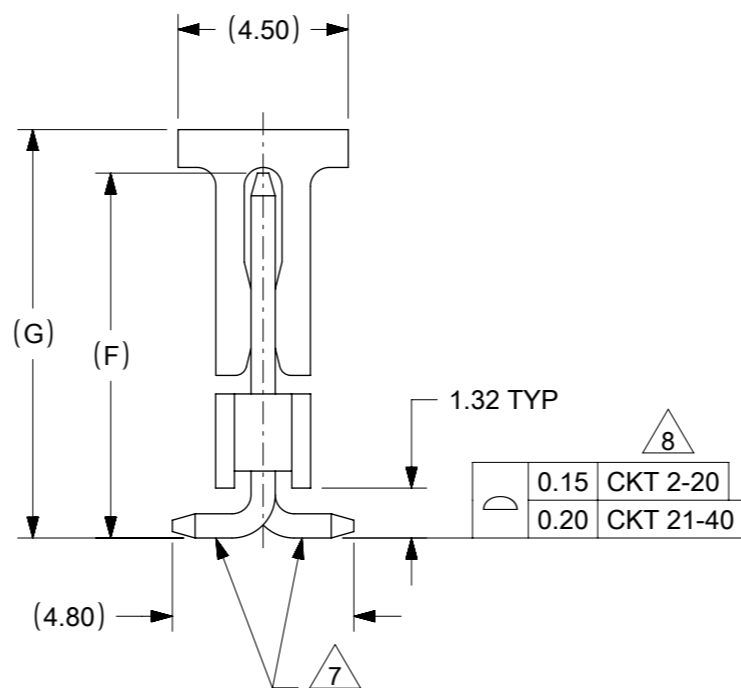

NOTES:

- MATERIAL:  
HSG: NYLON, GLASS-FILLED, UL94V-0, COLOR: BLACK  
CAP: NYLON, GLASS-FILLED, UL94V-0, COLOR: BLACK  
PIN: 0.64MM SQ, COPPER ALLOY
- PLATING TYPE:  
(1) GOLD FLASH OVER  
1.25µm MIN. NICKEL OVERALL.  
(2) GOLD FLASH ON CONTACT AND  
2.50µm MIN. TIN ON SOLDER TAIL OVER  
1.25µm MIN. NICKEL OVERALL.  
(4) 0.38µm MIN. GOLD PLATE ON CONTACT AND  
2.00µm MIN. TIN ON SOLDER TAIL OVER  
1.25µm MIN. NICKEL OVERALL.  
(5) 0.75µm MIN. GOLD PLATE ON CONTACT AND  
2.00µm MIN. TIN ON SOLDER TAIL OVER  
1.25µm MIN. NICKEL OVERALL.  
(6) 2.50µm MIN. TIN OVERALL  
1.25µm MIN. NICKEL OVERALL
- PRODUCT SPECIFICATION: PS-87920-019
- PACKAGING TYPE: SEE TABLE
- PACKAGING SPEC:  
TUBE WITH CAP VERSION: PK-89990-558  
TUBE W/O CAP VERSION: PK-89990-545  
TRAY W/O CAP: PK-89990-489  
EMBOSS TAPE WITH CAP: PK-89990-486 AND PK-87898-400
- WAFER TO BE FLAT WITHIN 0.003 mm/mm
- BEND DEPRESSION IS ACCEPTED SO LONG AS IT DOES NOT AFFECT THE OVERALL COPLANARITY OF TAIL
- COPLANARITY IS TO BE MEASURED BY RESTING THE SOLDER TAIL ON A FLAT SURFACE
- IRREGULAR CIRCUIT CUTOFF WITHIN BREAKAWAY SECTION IS PERMISSIBLE. CUTTING OR CHIPPING OF THE MAIN BODY IS NOT ACCEPTABLE
- CAP LOCATION IS CENTERED ALONG THE MATING ENDS AS SHOWN. TOP SURFACE OF CAP TO BE FLAT FOR THE PURPOSE OF PICK & PLACE BY VACUUM SUCTION NOZZLE
- RECOMMENDED PCB THICKNESS IS 1.60mm±0.10
- THE ABOVE CKT 6 IS FOR ILLUSTRATION PURPOSE ONLY
- TUBE LENGTH AS PER STANDARD 560mm

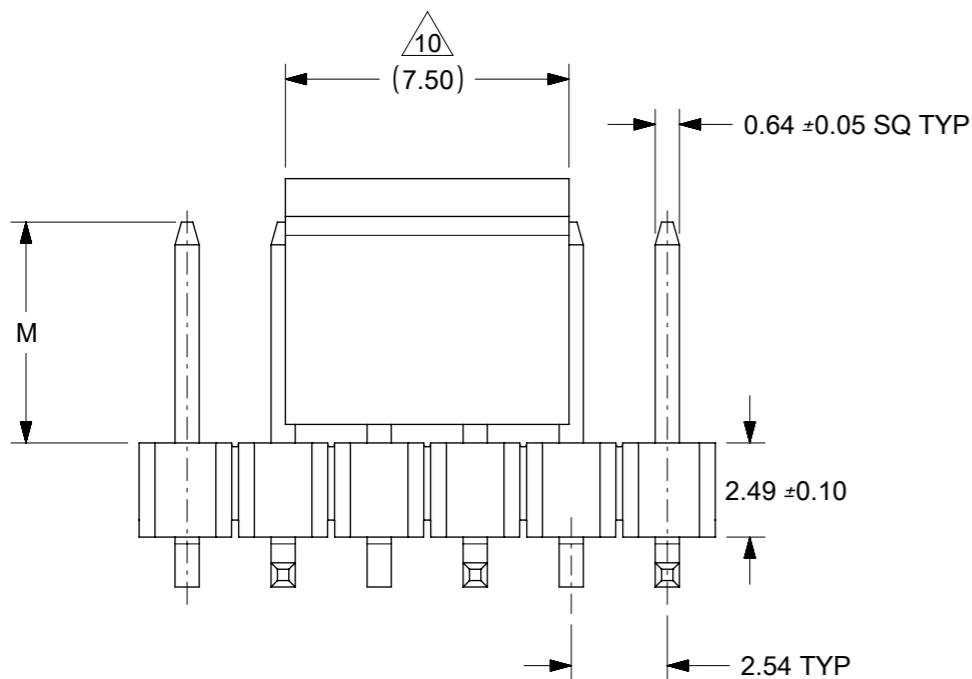
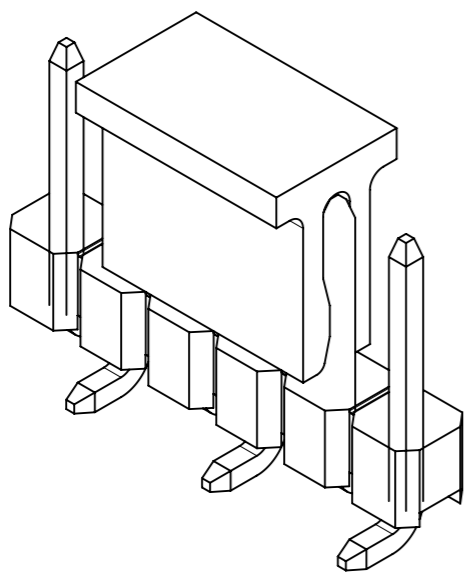

THIS DRAWING CONTAINS INFORMATION THAT IS PROPRIETARY TO MOLEX ELECTRONIC TECHNOLOGIES, LLC AND SHOULD NOT BE USED WITHOUT WRITTEN PERMISSION

ADD -0318 & -0458 EC NO: 168622 DRWN: FCSOC CHK'D: CGOH REV APPR: KHLIM	2017/11/27	2017/11/27	2017/12/12	GENERAL TOLERANCES (UNLESS SPECIFIED)		DIMENSION UNITS		SCALE					
	MM		INCH		MM		NTS						
	4 PLACES	±	±	YLQIAO	DATE		2005/03/14		CUSTOM HEADER 2.54MM PITCH SINGLE ROW SINGLE WAFER SMT HEADER				
	3 PLACES	±	±	CHK'D BY	DATE		2005/03/29						
	2 PLACES	±	0.2	±	PTLIM	DATE		2010/10/04		PRODUCT CUSTOMER DRAWING			
1 PLACES	±	±	APPR BY	DATE		MLONG							
0 PLACES	±	±	DRAWING SIZE	THIRD ANGLE PROJECTION		A3				SERIES: 87898 MATERIAL NUMBER: SEE TABLE CUSTOMER: GENERAL MARKET			
DRAFT WHERE APPLICABLE MUST REMAIN WITHIN DIMENSIONS		ANGULAR TOL = 3.0		DRAWING SIZE		THIRD ANGLE PROJECTION		A3		DOCUMENT NUMBER: SD-87898-001 DOC TYPE: PSD DOC PART: 000 SHEET NUMBER: 1 OF 21			

RELEASE STATUS	RELEASE DATE
----------------	--------------

9

8

7

6

5

4

3

2

1

PACKAGING OPTION PART NO.

TRAY WITHOUT CAP	TRAY WITH CAP	TUBE WITHOUT CAP	TUBE WITH CAP	TAPE & REEL WITHOUT CAP	TAPE & REEL WITH CAP	CKT SIZE	VOID POSITION	PLATING TYPE	DIMENSION				
									A	B	G	F	M
87898-0301	-----	-----	-----	-----	-----	3	----	1	7.62	5.08	10.81	9.65	5.84
87898-0302	-----	-----	-----	-----	-----	3	----	2	7.62	5.08	10.81	9.65	5.84
87898-0304	-----	-----	-----	-----	87898-0314	3	----	4	7.62	5.08	10.81	9.65	5.84
87898-0305	-----	-----	-----	-----	87898-0315	3	----	5	7.62	5.08	10.81	9.65	5.84
87898-0306	-----	-----	-----	-----	87898-0316	3	----	6	7.62	5.08	10.81	9.65	5.84
-----	-----	-----	-----	-----	87898-0317	3	-----	6	7.62	5.08	10.81	9.65	5.84
-----	-----	-----	-----	-----	(B18) 87898-0318	3	----	5	7.62	5.08	10.81	9.65	5.84

REFER TO LAST SHEET FOR 2CKT SIZE

THIS DRAWING CONTAINS INFORMATION THAT IS PROPRIETARY TO MOLEX ELECTRONIC TECHNOLOGIES, LLC AND SHOULD NOT BE USED WITHOUT WRITTEN PERMISSION

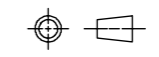
ADD P/N: 87898-0317 EC NO: 168622 DRWN: FCSCC CHK'D: CGOH REV APPR: KHLIM	2017/11/27	2017/11/27	2017/12/12	GENERAL TOLERANCES (UNLESS SPECIFIED)		DIMENSION UNITS		SCALE		 CUSTOM HEADER 2.54MM PITCH SINGLE ROW SINGLE WAFER SMT HEADER			
				MM	INCH	MM	INCH	NTS					
	4 PLACES	±	±	YLQIAO	DATE	PRODUCT CUSTOMER DRAWING							
	3 PLACES	±	±	PTLIM	2005/03/14								
	2 PLACES	±	0.2	±	CHK'D BY	DATE	SERIES: 87898    MATERIAL NUMBER: SEE TABLE    CUSTOMER: GENERAL MARKET						
1 PLACES	±	±	PTLIM	2005/03/29									
0 PLACES	±	±	MLONG	DATE	DOCUMENT NUMBER: SD-87898-001    DOC TYPE: PSD    DOC PART: 000    SHEET NUMBER: 2 OF 21								
			MLONG	2010/10/04									
ANGULAR TOL = 3.0				DRAWING SIZE	THIRD ANGLE PROJECTION								
DRAFT WHERE APPLICABLE MUST REMAIN WITHIN DIMENSIONS				A3									

RELEASE STATUS	RELEASE DATE
----------------	--------------

9		8		7		6		5		4					3	2	1
PACKAGING OPTION PART NO.						CKT SIZE	VOID POSITION	PLATING TYPE	DIMENSION								
TRAY WITHOUT CAP	TRAY WITH CAP	TUBE WITHOUT CAP	TUBE WITH CAP	TAPE & REEL WITHOUT CAP	TAPE & REEL WITH CAP				A	B	G	F	M				
-----	-----	87898-0421	87898-0431	-----	87898-0451	4	----	1	10.16	7.62	10.81	9.65	5.84				
-----	-----	87898-0422	87898-0432	-----	87898-0452	4	----	2	10.16	7.62	10.81	9.65	5.84				
-----	-----	87898-0424	87898-0434	-----	87898-0454	4	----	4	10.16	7.62	10.81	9.65	5.84				
-----	-----	87898-0425	87898-0435	-----	87898-0455	4	----	5	10.16	7.62	10.81	9.65	5.84				
-----	-----	87898-0426	87898-0436	-----	87898-0456	4	----	6	10.16	7.62	10.81	9.65	5.84				
-----	-----	-----	-----	-----	87898-0457	4	----	6	10.16	7.62	10.81	9.65	5.84				
-----	-----	-----	-----	-----	87898-0458	4	----	5	10.16	7.62	10.81	9.65	5.84				
-----	-----	87898-0521	87898-0531	-----	87898-0551	5	----	1	12.70	10.16	10.81	9.65	5.84				
-----	-----	87898-0522	87898-0532	-----	87898-0552	5	----	2	12.70	10.16	10.81	9.65	5.84				
-----	-----	87898-0524	87898-0534	-----	87898-0554	5	----	4	12.70	10.16	10.81	9.65	5.84				
-----	-----	87898-0525	87898-0535	-----	87898-0555	5	----	5	12.70	10.16	10.81	9.65	5.84				
-----	-----	87898-0526	87898-0536	-----	87898-0556	5	----	6	12.70	10.16	10.81	9.65	5.84				
-----	-----	87898-0621	87898-0631	-----	87898-0651	6	----	1	15.24	12.70	10.81	9.65	5.84				
-----	-----	87898-0622	87898-0632	-----	87898-0652	6	----	2	15.24	12.70	10.81	9.65	5.84				
-----	-----	87898-0624	87898-0634	-----	87898-0654	6	----	4	15.24	12.70	10.81	9.65	5.84				
-----	-----	87898-0625	87898-0635	-----	87898-0655	6	----	5	15.24	12.70	10.81	9.65	5.84				
-----	-----	87898-0626	87898-0636	-----	87898-0656	6	----	6	15.24	12.70	10.81	9.65	5.84				
87898-0607	-----	-----	-----	-----	87898-0657	6	----	6	15.24	12.70	16.47	15.31	11.50				



THIS DRAWING CONTAINS INFORMATION THAT IS PROPRIETARY TO MOLEX ELECTRONIC TECHNOLOGIES, LLC AND SHOULD NOT BE USED WITHOUT WRITTEN PERMISSION

ADD P/N: 87898-0457 EC NO: 168622 DRWN: FCSCC CHK'D: CGOH REV APPR: KHLIM	2017/11/27	GENERAL TOLERANCES (UNLESS SPECIFIED)		DIMENSION UNITS		SCALE						
	2017/11/27	MM	INCH	MM	NTS	DRWN BY	DATE					
	2017/12/12	4 PLACES	±	±	YLQIAO		2005/03/14		CUSTOM HEADER 2.54MM PITCH SINGLE ROW SINGLE WAFER SMT HEADER			
		3 PLACES	±	±	CHK'D BY		DATE					
		2 PLACES	± 0.2	±	PTLIM		2005/03/29		PRODUCT CUSTOMER DRAWING			
		1 PLACES	±	±	APPR BY		DATE					
	0 PLACES	±	±	MLONG		2010/10/04		SERIES	MATERIAL NUMBER	CUSTOMER		
		ANGULAR TOL = 3.0		DRAWING SIZE		THIRD ANGLE PROJECTION		87898	SEE TABLE	GENERAL MARKET		
		DRAFT WHERE APPLICABLE MUST REMAIN WITHIN DIMENSIONS		A3				DOCUMENT NUMBER	DOC TYPE	DOC PART	SHEET NUMBER	
	B19							SD-87898-001	PSD	000	3 OF 21	

9

8

7

6

5

4

3

2

1

PACKAGING OPTION PART NO.

DIMENSION

TRAY WITHOUT CAP	TRAY WITH CAP	TUBE WITHOUT CAP	TUBE WITH CAP	TAPE & REEL WITHOUT CAP	TAPE & REEL WITH CAP	CKT SIZE	VOID POSITION	PLATING TYPE	A	B	G	F	M
-----	-----	87898-0721	87898-0731	-----	87898-0751	7	-----	1	17.78	15.24	10.81	9.65	5.84
-----	-----	87898-0722	87898-0732	-----	87898-0752	7	-----	2	17.78	15.24	10.81	9.65	5.84
-----	-----	87898-0724	87898-0734	-----	87898-0754	7	-----	4	17.78	15.24	10.81	9.65	5.84
-----	-----	87898-0725	87898-0735	-----	87898-0755	7	-----	5	17.78	15.24	10.81	9.65	5.84
-----	-----	87898-0726	87898-0736	-----	87898-0756	7	-----	6	17.78	15.24	10.81	9.65	5.84
-----	-----	87898-0821	87898-0831	-----	87898-0851	8	-----	1	20.32	17.78	10.81	9.65	5.84
-----	-----	87898-0822	87898-0832	-----	87898-0852	8	-----	2	20.32	17.78	10.81	9.65	5.84
-----	-----	87898-0824	87898-0834	-----	87898-0854	8	-----	4	20.32	17.78	10.81	9.65	5.84
-----	-----	87898-0825	87898-0835	-----	87898-0855	8	-----	5	20.32	17.78	10.81	9.65	5.84
-----	-----	87898-0826	87898-0836	-----	87898-0856	8	-----	6	20.32	17.78	10.81	9.65	5.84
-----	-----	87898-0921	87898-0931	-----	87898-0951	9	-----	1	22.86	20.32	10.81	9.65	5.84
-----	-----	87898-0922	87898-0932	-----	87898-0952	9	-----	2	22.86	20.32	10.81	9.65	5.84
-----	-----	87898-0924	87898-0934	-----	87898-0954	9	-----	4	22.86	20.32	10.81	9.65	5.84
-----	-----	87898-0925	87898-0935	-----	87898-0955	9	-----	5	22.86	20.32	10.81	9.65	5.84
-----	-----	87898-0926	87898-0936	-----	87898-0956	9	-----	6	22.86	20.32	10.81	9.65	5.84

THIS DRAWING CONTAINS INFORMATION THAT IS PROPRIETARY TO MOLEX ELECTRONIC TECHNOLOGIES, LLC AND SHOULD NOT BE USED WITHOUT WRITTEN PERMISSION

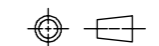
ADD -0318 & -0458 EC NO: 168622 DRWN: FCSCC CHK'D: CGOH REV APPR: KHLIM	2017/11/27	2017/11/27	2017/12/12	GENERAL TOLERANCES (UNLESS SPECIFIED)		DIMENSION UNITS		SCALE		 <b>CUSTOM HEADER</b> 2.54MM PITCH SINGLE ROW SINGLE WAFER SMT HEADER			
	MM		INCH		MM		NTS						
	4 PLACES	±	±	±	DRWN BY	DATE			<b>PRODUCT CUSTOMER DRAWING</b>				
	3 PLACES	±	±	±	YLQIAO	2005/03/14							
	2 PLACES	±	0.2	±	CHK'D BY	DATE			SERIES: 87898    MATERIAL NUMBER: SEE TABLE    CUSTOMER: GENERAL MARKET				
1 PLACES	±	±	±	PTLIM	2005/03/29								
0 PLACES	±	±	±	APPR BY	DATE			DOCUMENT NUMBER: SD-87898-001    DOC TYPE: PSD    DOC PART: 000    SHEET NUMBER: 4 OF 21					
ANGULAR TOL = 3.0				MLONG	2010/10/04								
DRAFT WHERE APPLICABLE MUST REMAIN WITHIN DIMENSIONS				DRAWING SIZE	THIRD ANGLE PROJECTION								
				A3									

RELEASE STATUS	RELEASE DATE
----------------	--------------

9

8

7

6

5

4

3

2

1

FORMA: Met-lega-master-ib-prod-A3  
REVISION: C  
DATE: 2016/02/04

9

8

7

6

5

4

3

2

1

PACKAGING OPTION PART NO.

DIMENSION

TRAY WITHOUT CAP	TRAY WITH CAP	TUBE WITHOUT CAP	TUBE WITH CAP	TAPE & REEL WITHOUT CAP	TAPE & REEL WITH CAP	CKT SIZE	VOID POSITION	PLATING TYPE	A	B	G	F	M
-----	-----	87898-1021	87898-1031	-----	87898-1051	10	-----	1	25.40	22.86	10.81	9.65	5.84
-----	-----	87898-1022	87898-1032	-----	87898-1052	10	-----	2	25.40	22.86	10.81	9.65	5.84
-----	-----	87898-1024	87898-1034	-----	87898-1054	10	-----	4	25.40	22.86	10.81	9.65	5.84
-----	-----	87898-1025	87898-1035	-----	87898-1055	10	-----	5	25.40	22.86	10.81	9.65	5.84
-----	-----	87898-1026	87898-1036	-----	87898-1056	10	-----	6	25.40	22.86	10.81	9.65	5.84
-----	-----	87898-1121	87898-1131	-----	87898-1151	11	-----	1	27.94	25.40	10.81	9.65	5.84
-----	-----	87898-1122	87898-1132	-----	87898-1152	11	-----	2	27.94	25.40	10.81	9.65	5.84
-----	-----	87898-1124	87898-1134	-----	87898-1154	11	-----	4	27.94	25.40	10.81	9.65	5.84
-----	-----	87898-1125	87898-1135	-----	87898-1155	11	-----	5	27.94	25.40	10.81	9.65	5.84
-----	-----	87898-1126	87898-1136	-----	87898-1156	11	-----	6	27.94	25.40	10.81	9.65	5.84
-----	-----	87898-1221	87898-1231	-----	87898-1251	12	-----	1	30.48	27.94	10.81	9.65	5.84
-----	-----	87898-1222	87898-1232	-----	87898-1252	12	-----	2	30.48	27.94	10.81	9.65	5.84
-----	-----	87898-1224	87898-1234	-----	87898-1254	12	-----	4	30.48	27.94	10.81	9.65	5.84
-----	-----	87898-1225	87898-1235	-----	87898-1255	12	-----	5	30.48	27.94	10.81	9.65	5.84
-----	-----	87898-1226	87898-1236	-----	87898-1256	12	-----	6	30.48	27.94	10.81	9.65	5.84

THIS DRAWING CONTAINS INFORMATION THAT IS PROPRIETARY TO MOLEX ELECTRONIC TECHNOLOGIES, LLC AND SHOULD NOT BE USED WITHOUT WRITTEN PERMISSION

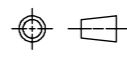
ADD -0318 & -0458 EC NO: 168622 DRWN: FCSCC CHK'D: CGOH REV APPR: KHLIM	GENERAL TOLERANCES (UNLESS SPECIFIED)		DIMENSION UNITS		SCALE				
			MM	INCH	MM	NTS			
	4 PLACES ±		MM	INCH	DRWN BY	DATE	CUSTOM HEADER 2.54MM PITCH SINGLE ROW SINGLE WAFER SMT HEADER		
	3 PLACES ±		MM	INCH	YLQIAO	2005/03/14			
	2 PLACES ± 0.2		MM	INCH	CHK'D BY	DATE			
	1 PLACES ±		MM	INCH	PTLIM	2005/03/29			
	0 PLACES ±		MM	INCH	APPR BY	DATE			
	ANGULAR TOL = 3.0		DRAFT WHERE APPLICABLE MUST REMAIN WITHIN DIMENSIONS		MLONG	2010/10/04	PRODUCT CUSTOMER DRAWING		
			DRAFT WHERE APPLICABLE MUST REMAIN WITHIN DIMENSIONS		DRAWING SIZE	THIRD ANGLE PROJECTION	SERIES	MATERIAL NUMBER	CUSTOMER
			DRAFT WHERE APPLICABLE MUST REMAIN WITHIN DIMENSIONS		A3		87898	SEE TABLE	GENERAL MARKET
		DRAFT WHERE APPLICABLE MUST REMAIN WITHIN DIMENSIONS				DOCUMENT NUMBER	DOC TYPE	DOC PART	SHEET NUMBER
		DRAFT WHERE APPLICABLE MUST REMAIN WITHIN DIMENSIONS				SD-87898-001	PSD	000	5 OF 21

RELEASE STATUS	RELEASE DATE
----------------	--------------

9

8

7

6

5

4

3

2

1

FORMA: Met-lega-master-ib-prod-A3  
REVISION: C  
DATE: 2016/02/04

PACKAGING OPTION PART NO.						CKT SIZE	VOID POSITION	PLATING TYPE	DIMENSION				
TRAY WITHOUT CAP	TRAY WITH CAP	TUBE WITHOUT CAP	TUBE WITH CAP	TAPE & REEL WITHOUT CAP	TAPE & REEL WITH CAP				A	B	G	F	M
-----	-----	87898-1321	87898-1331	-----	87898-1351	13	----	1	33.02	30.48	10.81	9.65	5.84
-----	-----	87898-1322	87898-1332	-----	87898-1352	13	----	2	33.02	30.48	10.81	9.65	5.84
-----	-----	87898-1324	87898-1334	-----	87898-1354	13	----	4	33.02	30.48	10.81	9.65	5.84
-----	-----	87898-1325	87898-1335	-----	87898-1355	13	----	5	33.02	30.48	10.81	9.65	5.84
-----	-----	87898-1326	87898-1336	-----	87898-1356	13	----	6	33.02	30.48	10.81	9.65	5.84
-----	-----	87898-1421	87898-1431	-----	87898-1451	14	----	1	35.56	33.02	10.81	9.65	5.84
-----	-----	87898-1422	87898-1432	-----	87898-1452	14	----	2	35.56	33.02	10.81	9.65	5.84
-----	-----	87898-1424	87898-1434	-----	87898-1454	14	----	4	35.56	33.02	10.81	9.65	5.84
-----	-----	87898-1425	87898-1435	-----	87898-1455	14	----	5	35.56	33.02	10.81	9.65	5.84
-----	-----	87898-1426	87898-1436	-----	87898-1456	14	----	6	35.56	33.02	10.81	9.65	5.84
-----	-----	87898-1521	87898-1531	-----	87898-1551	15	----	1	38.10	35.56	10.81	9.65	5.84
-----	-----	87898-1522	87898-1532	-----	87898-1552	15	----	2	38.10	35.56	10.81	9.65	5.84
-----	-----	87898-1524	87898-1534	-----	87898-1554	15	----	4	38.10	35.56	10.81	9.65	5.84
-----	-----	87898-1525	87898-1535	-----	87898-1555	15	----	5	38.10	35.56	10.81	9.65	5.84
-----	-----	87898-1526	87898-1536	-----	87898-1556	15	----	6	38.10	35.56	10.81	9.65	5.84

THIS DRAWING CONTAINS INFORMATION THAT IS PROPRIETARY TO MOLEX ELECTRONIC TECHNOLOGIES, LLC AND SHOULD NOT BE USED WITHOUT WRITTEN PERMISSION

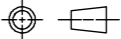
ADD -0318 & -0458 EC NO: 168622 DRWN: FCSCC CHK'D: CGOH REV APPR: KHLIM	GENERAL TOLERANCES (UNLESS SPECIFIED)		DIMENSION UNITS		SCALE				
	MM	INCH	MM	INCH	MM	NTS			
	4 PLACES ±	±	DRWN BY		DATE		CUSTOM HEADER 2.54MM PITCH SINGLE ROW SINGLE WAFER SMT HEADER		
	3 PLACES ±	±	YLQIAO		2005/03/14				
	2 PLACES ± 0.2	±	CHK'D BY		DATE				
	1 PLACES ±	±	PTLIM		2005/03/29		PRODUCT CUSTOMER DRAWING		
	0 PLACES ±	±	APPR BY		DATE				
	ANGULAR TOL = 3.0		MLONG		2010/10/04		SERIES	MATERIAL NUMBER	CUSTOMER
	DRAFT WHERE APPLICABLE MUST REMAIN WITHIN DIMENSIONS		DRAWING SIZE		THIRD ANGLE PROJECTION		87898	SEE TABLE	GENERAL MARKET
	A3				DOCUMENT NUMBER		SD-87898-001	DOC TYPE	DOC PART
B19						PSD	000	6 OF 21	

RELEASE STATUS	RELEASE DATE
----------------	--------------

PACKAGING OPTION PART NO.						CKT SIZE	VOID POSITION	PLATING TYPE	DIMENSION				
TRAY WITHOUT CAP	TRAY WITH CAP	TUBE WITHOUT CAP	TUBE WITH CAP	TAPE & REEL WITHOUT CAP	TAPE & REEL WITH CAP				A	B	G	F	M
-----	-----	87898-1621	87898-1631	-----	87898-1651	16	----	1	40.64	38.10	10.81	9.65	5.84
-----	-----	87898-1622	87898-1632	-----	87898-1652	16	----	2	40.64	38.10	10.81	9.65	5.84
-----	-----	87898-1624	87898-1634	-----	87898-1654	16	----	4	40.64	38.10	10.81	9.65	5.84
-----	-----	87898-1625	87898-1635	-----	87898-1655	16	----	5	40.64	38.10	10.81	9.65	5.84
-----	-----	87898-1626	87898-1636	-----	87898-1656	16	----	6	40.64	38.10	10.81	9.65	5.84
-----	-----	87898-1721	87898-1731	-----	87898-1751	17	----	1	43.18	40.64	10.81	9.65	5.84
-----	-----	87898-1722	87898-1732	-----	87898-1752	17	----	2	43.18	40.64	10.81	9.65	5.84
-----	-----	87898-1724	87898-1734	-----	87898-1754	17	----	4	43.18	40.64	10.81	9.65	5.84
-----	-----	87898-1725	87898-1735	-----	87898-1755	17	----	5	43.18	40.64	10.81	9.65	5.84
-----	-----	87898-1726	87898-1736	-----	87898-1756	17	----	6	43.18	40.64	10.81	9.65	5.84
-----	-----	87898-1821	87898-1831	-----	87898-1851	18	----	1	45.72	43.18	10.81	9.65	5.84
-----	-----	87898-1822	87898-1832	-----	87898-1852	18	----	2	45.72	43.18	10.81	9.65	5.84
-----	-----	87898-1824	87898-1834	-----	87898-1854	18	----	4	45.72	43.18	10.81	9.65	5.84
-----	-----	87898-1825	87898-1835	-----	87898-1855	18	----	5	45.72	43.18	10.81	9.65	5.84
-----	-----	87898-1826	87898-1836	-----	87898-1856	18	----	6	45.72	43.18	10.81	9.65	5.84

THIS DRAWING CONTAINS INFORMATION THAT IS PROPRIETARY TO MOLEX ELECTRONIC TECHNOLOGIES, LLC AND SHOULD NOT BE USED WITHOUT WRITTEN PERMISSION

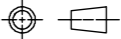
ADD -0318 & -0458 EC NO: 168622 DRWN: FCSCC CHK'D: CGOH REV APPR: KHLIM	GENERAL TOLERANCES (UNLESS SPECIFIED)		DIMENSION UNITS		SCALE				
			MM	INCH	MM	NTS			
	4 PLACES ±		DRWN BY		DATE		CUSTOM HEADER 2.54MM PITCH SINGLE ROW SINGLE WAFER SMT HEADER		
	3 PLACES ±		YLQIAO		2005/03/14				
	2 PLACES ± 0.2		CHK'D BY		DATE				
	1 PLACES ±		PTLIM		2005/03/29				
	0 PLACES ±		APPR BY		DATE		PRODUCT CUSTOMER DRAWING		
			MLONG		2010/10/04				
	ANGULAR TOL = 3.0		DRAWING SIZE		THIRD ANGLE PROJECTION		SERIES	MATERIAL NUMBER	CUSTOMER
	DRAFT WHERE APPLICABLE MUST REMAIN WITHIN DIMENSIONS		A3				87898	SEE TABLE	GENERAL MARKET
						DOCUMENT NUMBER	DOC TYPE	DOC PART	SHEET NUMBER
						SD-87898-001	PSD	000	7 OF 21

RELEASE STATUS	RELEASE DATE
----------------	--------------

PACKAGING OPTION PART NO.						CKT SIZE	VOID POSITION	PLATING TYPE	DIMENSION				
TRAY WITHOUT CAP	TRAY WITH CAP	TUBE WITHOUT CAP	TUBE WITH CAP	TAPE & REEL WITHOUT CAP	TAPE & REEL WITH CAP				A	B	G	F	M
-----	-----	87898-1921	87898-1931	-----	87898-1951	19	----	1	48.26	45.72	10.81	9.65	5.84
-----	-----	87898-1922	87898-1932	-----	87898-1952	19	----	2	48.26	45.72	10.81	9.65	5.84
-----	-----	87898-1924	87898-1934	-----	87898-1954	19	----	4	48.26	45.72	10.81	9.65	5.84
-----	-----	87898-1925	87898-1935	-----	87898-1955	19	----	5	48.26	45.72	10.81	9.65	5.84
-----	-----	87898-1926	87898-1936	-----	87898-1956	19	----	6	48.26	45.72	10.81	9.65	5.84
-----	-----	87898-2021	87898-2031	-----	87898-2051	20	----	1	50.80	48.26	10.81	9.65	5.84
-----	-----	87898-2022	87898-2032	-----	87898-2052	20	----	2	50.80	48.26	10.81	9.65	5.84
-----	-----	87898-2024	87898-2034	-----	87898-2054	20	----	4	50.80	48.26	10.81	9.65	5.84
-----	-----	87898-2025	87898-2035	-----	87898-2055	20	----	5	50.80	48.26	10.81	9.65	5.84
-----	-----	87898-2026	87898-2036	-----	87898-2056	20	----	6	50.80	48.26	10.81	9.65	5.84
-----	-----	87898-2121	87898-2131	-----	87898-2151	21	----	1	53.34	50.80	10.81	9.65	5.84
-----	-----	87898-2122	87898-2132	-----	87898-2152	21	----	2	53.34	50.80	10.81	9.65	5.84
-----	-----	87898-2124	87898-2134	-----	87898-2154	21	----	4	53.34	50.80	10.81	9.65	5.84
-----	-----	87898-2125	87898-2135	-----	87898-2155	21	----	5	53.34	50.80	10.81	9.65	5.84
-----	-----	87898-2126	87898-2136	-----	87898-2156	21	----	6	53.34	50.80	10.81	9.65	5.84

THIS DRAWING CONTAINS INFORMATION THAT IS PROPRIETARY TO MOLEX ELECTRONIC TECHNOLOGIES, LLC AND SHOULD NOT BE USED WITHOUT WRITTEN PERMISSION

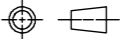
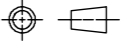
ADD -0318 & -0458 EC NO: 168622 DRWN: FCSCC CHK'D: CGOH REV APPR: KHLIM	GENERAL TOLERANCES (UNLESS SPECIFIED)		DIMENSION UNITS		SCALE				
	MM	INCH	MM	INCH	MM	NTS			
	4 PLACES ±	±	DRWN BY		DATE		CUSTOM HEADER 2.54MM PITCH SINGLE ROW SINGLE WAFER SMT HEADER		
	3 PLACES ±	±	YLQIAO		2005/03/14				
	2 PLACES ±	0.2 ±	CHK'D BY		DATE				
	1 PLACES ±	±	PTLIM		2005/03/29		PRODUCT CUSTOMER DRAWING		
	0 PLACES ±	±	APPR BY		DATE				
	ANGULAR TOL = 3.0		MLONG		2010/10/04		SERIES	MATERIAL NUMBER	CUSTOMER
	DRAFT WHERE APPLICABLE MUST REMAIN WITHIN DIMENSIONS		DRAWING SIZE		THIRD ANGLE PROJECTION		87898	SEE TABLE	GENERAL MARKET
	A3		A3				DOCUMENT NUMBER	DOC TYPE	DOC PART
B19		A3				SD-87898-001	PSD	000	8 OF 21

RELEASE STATUS	RELEASE DATE
----------------	--------------



PACKAGING OPTION PART NO.						CKT SIZE	VOID POSITION	PLATING TYPE	DIMENSION				
TRAY WITHOUT CAP	TRAY WITH CAP	TUBE WITHOUT CAP	TUBE WITH CAP	TAPE & REEL WITHOUT CAP	TAPE & REEL WITH CAP				A	B	G	F	M
-----	-----	87898-2221	87898-2231	-----	-----	22	----	1	55.88	53.34	10.81	9.65	5.84
-----	-----	87898-2222	87898-2232	-----	-----	22	----	2	55.88	53.34	10.81	9.65	5.84
-----	-----	87898-2224	87898-2234	-----	-----	22	----	4	55.88	53.34	10.81	9.65	5.84
-----	-----	87898-2225	87898-2235	-----	-----	22	----	5	55.88	53.34	10.81	9.65	5.84
-----	-----	87898-2226	87898-2236	-----	-----	22	----	6	55.88	53.34	10.81	9.65	5.84
-----	-----	87898-2321	87898-2331	-----	-----	23	----	1	58.42	55.88	10.81	9.65	5.84
-----	-----	87898-2322	87898-2332	-----	-----	23	----	2	58.42	55.88	10.81	9.65	5.84
-----	-----	87898-2324	87898-2334	-----	-----	23	----	4	58.42	55.88	10.81	9.65	5.84
-----	-----	87898-2325	87898-2335	-----	-----	23	----	5	58.42	55.88	10.81	9.65	5.84
-----	-----	87898-2326	87898-2336	-----	-----	23	----	6	58.42	55.88	10.81	9.65	5.84
-----	-----	87898-2421	87898-2431	-----	-----	24	----	1	60.96	58.42	10.81	9.65	5.84
-----	-----	87898-2422	87898-2432	-----	-----	24	----	2	60.96	58.42	10.81	9.65	5.84
-----	-----	87898-2424	87898-2434	-----	-----	24	----	4	60.96	58.42	10.81	9.65	5.84
-----	-----	87898-2425	87898-2435	-----	-----	24	----	5	60.96	58.42	10.81	9.65	5.84
-----	-----	87898-2426	87898-2436	-----	-----	24	----	6	60.96	58.42	10.81	9.65	5.84

THIS DRAWING CONTAINS INFORMATION THAT IS PROPRIETARY TO MOLEX ELECTRONIC TECHNOLOGIES, LLC AND SHOULD NOT BE USED WITHOUT WRITTEN PERMISSION

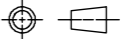
ADD -0318 & -0458 EC NO: 168622 DRWN: FCSOC CHK'D: CGOH REV APPR: KHLIM 2017/11/27 2017/11/27 2017/12/12	GENERAL TOLERANCES (UNLESS SPECIFIED)		DIMENSION UNITS		SCALE				
			MM	INCH	MM	NTS			
	4 PLACES ±		MM	INCH	DRWN BY	DATE	CUSTOM HEADER 2.54MM PITCH SINGLE ROW SINGLE WAFER SMT HEADER		
	3 PLACES ±		MM	INCH	YLQIAO	2005/03/14			
	2 PLACES ± 0.2		MM	INCH	CHK'D BY	DATE			
	1 PLACES ±		MM	INCH	PTLIM	2005/03/29	PRODUCT CUSTOMER DRAWING		
	0 PLACES ±		MM	INCH	APPR BY	DATE			
	ANGULAR TOL = 3.0		DRAFT WHERE APPLICABLE MUST REMAIN WITHIN DIMENSIONS		MLONG	2010/10/04	SERIES	MATERIAL NUMBER	CUSTOMER
					DRAWING SIZE	THIRD ANGLE PROJECTION	87898	SEE TABLE	GENERAL MARKET
					A3		DOCUMENT NUMBER	DOC TYPE	DOC PART
				B19		SD-87898-001	PSD	000	9 OF 21

RELEASE STATUS	RELEASE DATE
----------------	--------------

PACKAGING OPTION PART NO.

TRAY WITHOUT CAP	TRAY WITH CAP	TUBE		TAPE & REEL		CKT SIZE	VOID POSITION	PLATING TYPE	DIMENSION				
		WITHOUT CAP	WITH CAP	WITHOUT CAP	WITH CAP				A	B	G	F	M
-----	-----	87898-2521	87898-2531	-----	-----	25	----	1	63.50	60.96	10.81	9.65	5.84
-----	-----	87898-2522	87898-2532	-----	-----	25	----	2	63.50	60.96	10.81	9.65	5.84
-----	-----	87898-2524	87898-2534	-----	-----	25	----	4	63.50	60.96	10.81	9.65	5.84
-----	-----	87898-2525	87898-2535	-----	-----	25	----	5	63.50	60.96	10.81	9.65	5.84
-----	-----	87898-2526	87898-2536	-----	-----	25	----	6	63.50	60.96	10.81	9.65	5.84
-----	-----	87898-2621	87898-2631	-----	-----	26	----	1	66.04	63.50	10.81	9.65	5.84
-----	-----	87898-2622	87898-2632	-----	-----	26	----	2	66.04	63.50	10.81	9.65	5.84
-----	-----	87898-2624	87898-2634	-----	-----	26	----	4	66.04	63.50	10.81	9.65	5.84
-----	-----	87898-2625	87898-2635	-----	-----	26	----	5	66.04	63.50	10.81	9.65	5.84
-----	-----	87898-2626	87898-2636	-----	-----	26	----	6	66.04	63.50	10.81	9.65	5.84
-----	-----	87898-2721	87898-2731	-----	-----	27	----	1	68.58	66.04	10.81	9.65	5.84
-----	-----	87898-2722	87898-2732	-----	-----	27	----	2	68.58	66.04	10.81	9.65	5.84
-----	-----	87898-2724	87898-2734	-----	-----	27	----	4	68.58	66.04	10.81	9.65	5.84
-----	-----	87898-2725	87898-2735	-----	-----	27	----	5	68.58	66.04	10.81	9.65	5.84
-----	-----	87898-2726	87898-2736	-----	-----	27	----	6	68.58	66.04	10.81	9.65	5.84

THIS DRAWING CONTAINS INFORMATION THAT IS PROPRIETARY TO MOLEX ELECTRONIC TECHNOLOGIES, LLC AND SHOULD NOT BE USED WITHOUT WRITTEN PERMISSION

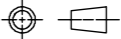
ADD -0318 & -0458 EC NO: 168622 DRWN: FCSCC CHK'D: CGOH REV APPR: KHLIM	2017/11/27	GENERAL TOLERANCES (UNLESS SPECIFIED)		DIMENSION UNITS		SCALE						
	2017/11/27	MM	INCH	MM	NTS	DRWN BY	DATE					
	2017/12/12	4 PLACES	±	±	YLQIAO	2005/03/14		CUSTOM HEADER 2.54MM PITCH SINGLE ROW SINGLE WAFER SMT HEADER				
		3 PLACES	±	±	CHK'D BY	DATE						
		2 PLACES	± 0.2	±	PTLIM	2005/03/29						
		1 PLACES	±	±	APPR BY	DATE		PRODUCT CUSTOMER DRAWING				
		0 PLACES	±	±	MLONG	2010/10/04						
		ANGULAR TOL = 3.0			DRAWING SIZE	THIRD ANGLE PROJECTION		SERIES	MATERIAL NUMBER	CUSTOMER		
		DRAFT WHERE APPLICABLE MUST REMAIN WITHIN DIMENSIONS			A3			87898	SEE TABLE	GENERAL MARKET		
								DOCUMENT NUMBER		DOC TYPE	DOC PART	SHEET NUMBER
							SD-87898-001		PSD	000	10 OF 21	

RELEASE STATUS	RELEASE DATE
----------------	--------------

FORMA: Met-lega-master-ib-prod-A3  
 REVISION: C  
 DATE: 2016/02/04

9

8

7

6

5

4

3

2

1

PACKAGING OPTION PART NO.

DIMENSION

TRAY WITHOUT CAP	TRAY WITH CAP	TUBE WITHOUT CAP	TUBE WITH CAP	TAPE & REEL WITHOUT CAP	TAPE & REEL WITH CAP	CKT SIZE	VOID POSITION	PLATING TYPE	A	B	G	F	M
-----	-----	87898-2821	87898-2831	-----	-----	28	-----	1	71.12	68.58	10.81	9.65	5.84
-----	-----	87898-2822	87898-2832	-----	-----	28	-----	2	71.12	68.58	10.81	9.65	5.84
-----	-----	87898-2824	87898-2834	-----	-----	28	-----	4	71.12	68.58	10.81	9.65	5.84
-----	-----	87898-2825	87898-2835	-----	-----	28	-----	5	71.12	68.58	10.81	9.65	5.84
-----	-----	87898-2826	87898-2836	-----	-----	28	-----	6	71.12	68.58	10.81	9.65	5.84
-----	-----	87898-2921	87898-2931	-----	-----	29	-----	1	73.66	71.12	10.81	9.65	5.84
-----	-----	87898-2922	87898-2932	-----	-----	29	-----	2	73.66	71.12	10.81	9.65	5.84
-----	-----	87898-2924	87898-2934	-----	-----	29	-----	4	73.66	71.12	10.81	9.65	5.84
-----	-----	87898-2925	87898-2935	-----	-----	29	-----	5	73.66	71.12	10.81	9.65	5.84
-----	-----	87898-2926	87898-2936	-----	-----	29	-----	6	73.66	71.12	10.81	9.65	5.84
-----	-----	87898-3021	87898-3031	-----	-----	30	-----	1	76.20	73.66	10.81	9.65	5.84
-----	-----	87898-3022	87898-3032	-----	-----	30	-----	2	76.20	73.66	10.81	9.65	5.84
-----	-----	87898-3024	87898-3034	-----	-----	30	-----	4	76.20	73.66	10.81	9.65	5.84
-----	-----	87898-3025	87898-3035	-----	-----	30	-----	5	76.20	73.66	10.81	9.65	5.84
-----	-----	87898-3026	87898-3036	-----	-----	30	-----	6	76.20	73.66	10.81	9.65	5.84

THIS DRAWING CONTAINS INFORMATION THAT IS PROPRIETARY TO MOLEX ELECTRONIC TECHNOLOGIES, LLC AND SHOULD NOT BE USED WITHOUT WRITTEN PERMISSION

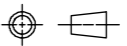
ADD -0318 & -0458 EC NO: 168622 DRWN: FCSCC CHK'D: CGOH REV APPR: KHLIM	2017/11/27	GENERAL TOLERANCES (UNLESS SPECIFIED)		DIMENSION UNITS		SCALE						
	2017/11/27	MM	INCH	MM	NTS	DRWN BY	DATE					
	2017/12/12	4 PLACES	±	±	YLQIAO		2005/03/14		CUSTOM HEADER 2.54MM PITCH SINGLE ROW SINGLE WAFER SMT HEADER			
		3 PLACES	±	±	CHK'D BY		DATE					
		2 PLACES	± 0.2	±	PTLIM		2005/03/29		PRODUCT CUSTOMER DRAWING			
		1 PLACES	±	±	APPR BY		DATE					
	0 PLACES	±	±	MLONG		2010/10/04		SERIES	MATERIAL NUMBER	CUSTOMER		
	ANGULAR TOL = 3.0			DRAWING SIZE		THIRD ANGLE PROJECTION		87898	SEE TABLE	GENERAL MARKET		
	DRAFT WHERE APPLICABLE MUST REMAIN WITHIN DIMENSIONS			A3				DOCUMENT NUMBER		DOC TYPE	DOC PART	SHEET NUMBER
	B19				SD-87898-001		PSD	000	11 OF 21			

RELEASE STATUS	RELEASE DATE
----------------	--------------

9

8

7

6

5

4

3

2

1

FORMA: Met-lega-master-ib-prod-A3  
REVISION: C  
DATE: 2016/02/04

PACKAGING OPTION PART NO.						CKT SIZE	VOID POSITION	PLATING TYPE	DIMENSION				
TRAY WITHOUT CAP	TRAY WITH CAP	TUBE WITHOUT CAP	TUBE WITH CAP	TAPE & REEL WITHOUT CAP	TAPE & REEL WITH CAP				A	B	G	F	M
-----	-----	87898-3121	87898-3131	-----	-----	31	----	1	78.74	76.20	10.81	9.65	5.84
-----	-----	87898-3122	87898-3132	-----	-----	31	----	2	78.74	76.20	10.81	9.65	5.84
-----	-----	87898-3124	87898-3134	-----	-----	31	----	4	78.74	76.20	10.81	9.65	5.84
-----	-----	87898-3125	87898-3135	-----	-----	31	----	5	78.74	76.20	10.81	9.65	5.84
-----	-----	87898-3126	87898-3136	-----	-----	31	----	6	78.74	76.20	10.81	9.65	5.84
-----	-----	87898-3221	87898-3231	-----	-----	32	----	1	81.28	78.74	10.81	9.65	5.84
-----	-----	87898-3222	87898-3232	-----	-----	32	----	2	81.28	78.74	10.81	9.65	5.84
-----	-----	87898-3224	87898-3234	-----	-----	32	----	4	81.28	78.74	10.81	9.65	5.84
-----	-----	87898-3225	87898-3235	-----	-----	32	----	5	81.28	78.74	10.81	9.65	5.84
-----	-----	87898-3226	87898-3236	-----	-----	32	----	6	81.28	78.74	10.81	9.65	5.84
-----	-----	87898-3321	87898-3331	-----	-----	33	----	1	83.82	81.28	10.81	9.65	5.84
-----	-----	87898-3322	87898-3332	-----	-----	33	----	2	83.82	81.28	10.81	9.65	5.84
-----	-----	87898-3324	87898-3334	-----	-----	33	----	4	83.82	81.28	10.81	9.65	5.84
-----	-----	87898-3325	87898-3335	-----	-----	33	----	5	83.82	81.28	10.81	9.65	5.84
-----	-----	87898-3326	87898-3336	-----	-----	33	----	6	83.82	81.28	10.81	9.65	5.84

THIS DRAWING CONTAINS INFORMATION THAT IS PROPRIETARY TO MOLEX ELECTRONIC TECHNOLOGIES, LLC AND SHOULD NOT BE USED WITHOUT WRITTEN PERMISSION

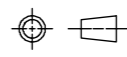
ADD -0318 & -0458 EC NO: 168622 DRWN: FCSCC CHK'D: CGOH REV APPR: KHLIM	2017/11/27	GENERAL TOLERANCES (UNLESS SPECIFIED)		DIMENSION UNITS		SCALE					
	2017/11/27	MM	INCH	MM	NTS	DRWN BY	DATE				
	2017/12/12	4 PLACES	±	±	YLQIAO	2005/03/14		CUSTOM HEADER 2.54MM PITCH SINGLE ROW SINGLE WAFER SMT HEADER			
		3 PLACES	±	±	CHK'D BY	DATE					
		2 PLACES	± 0.2	±	PTLIM	2005/03/29		PRODUCT CUSTOMER DRAWING			
		1 PLACES	±	±	APPR BY	DATE					
	0 PLACES	±	±	MLONG	2010/10/04		SERIES	MATERIAL NUMBER	CUSTOMER		
		ANGULAR TOL = 3.0		DRAWING SIZE	THIRD ANGLE PROJECTION		87898	SEE TABLE	GENERAL MARKET		
		DRAFT WHERE APPLICABLE MUST REMAIN WITHIN DIMENSIONS		A3			DOCUMENT NUMBER		DOC TYPE	DOC PART	SHEET NUMBER
							SD-87898-001		PSD	000	12 OF 21

RELEASE STATUS	RELEASE DATE
----------------	--------------

PACKAGING OPTION PART NO.						CKT SIZE	VOID POSITION	PLATING TYPE	DIMENSION				
TRAY WITHOUT CAP	TRAY WITH CAP	TUBE WITHOUT CAP	TUBE WITH CAP	TAPE & REEL WITHOUT CAP	TAPE & REEL WITH CAP				A	B	G	F	M
-----	-----	87898-3421	87898-3431	-----	-----	34	----	1	86.36	83.82	10.81	9.65	5.84
-----	-----	87898-3422	87898-3432	-----	-----	34	----	2	86.36	83.82	10.81	9.65	5.84
-----	-----	87898-3424	87898-3434	-----	-----	34	----	4	86.36	83.82	10.81	9.65	5.84
-----	-----	87898-3425	87898-3435	-----	-----	34	----	5	86.36	83.82	10.81	9.65	5.84
-----	-----	87898-3426	87898-3436	-----	-----	34	----	6	86.36	83.82	10.81	9.65	5.84
-----	-----	87898-3521	87898-3531	-----	-----	35	----	1	88.90	86.36	10.81	9.65	5.84
-----	-----	87898-3522	87898-3532	-----	-----	35	----	2	88.90	86.36	10.81	9.65	5.84
-----	-----	87898-3524	87898-3534	-----	-----	35	----	4	88.90	86.36	10.81	9.65	5.84
-----	-----	87898-3525	87898-3535	-----	-----	35	----	5	88.90	86.36	10.81	9.65	5.84
-----	-----	87898-3526	87898-3536	-----	-----	35	----	6	88.90	86.36	10.81	9.65	5.84
-----	-----	87898-3621	87898-3631	-----	-----	36	----	1	91.44	88.90	10.81	9.65	5.84
-----	-----	87898-3622	87898-3632	-----	-----	36	----	2	91.44	88.90	10.81	9.65	5.84
-----	-----	87898-3624	87898-3634	-----	-----	36	----	4	91.44	88.90	10.81	9.65	5.84
-----	-----	87898-3625	87898-3635	-----	-----	36	----	5	91.44	88.90	10.81	9.65	5.84
-----	-----	87898-3626	87898-3636	-----	-----	36	----	6	91.44	88.90	10.81	9.65	5.84

THIS DRAWING CONTAINS INFORMATION THAT IS PROPRIETARY TO MOLEX ELECTRONIC TECHNOLOGIES, LLC AND SHOULD NOT BE USED WITHOUT WRITTEN PERMISSION

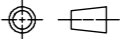
ADD -0318 & -0458 EC NO: 168622 DRWN: FCSCC CHK'D: CGOH REV APPR: KHLIM 2017/11/27 2017/11/27 2017/12/12	GENERAL TOLERANCES (UNLESS SPECIFIED)		DIMENSION UNITS		SCALE				
	MM	INCH	MM	INCH	MM	NTS			
	4 PLACES ±	±	DRWN BY		DATE		CUSTOM HEADER 2.54MM PITCH SINGLE ROW SINGLE WAFER SMT HEADER		
	3 PLACES ±	±	YLQIAO		2005/03/14				
	2 PLACES ± 0.2	±	CHK'D BY		DATE				
	1 PLACES ±	±	PTLIM		2005/03/29		PRODUCT CUSTOMER DRAWING		
	0 PLACES ±	±	APPR BY		DATE				
	ANGULAR TOL = 3.0		MLONG		2010/10/04		SERIES	MATERIAL NUMBER	CUSTOMER
	DRAFT WHERE APPLICABLE MUST REMAIN WITHIN DIMENSIONS		DRAWING SIZE		THIRD ANGLE PROJECTION		87898	SEE TABLE	GENERAL MARKET
	A3		A3				DOCUMENT NUMBER	DOC TYPE	DOC PART
B19		SD-87898-001		PSD		000	13 OF 21		

RELEASE STATUS	RELEASE DATE
----------------	--------------

9

8

7

6

5

4

3

2

1

PACKAGING OPTION PART NO.

DIMENSION

TRAY WITHOUT CAP	TRAY WITH CAP	TUBE WITHOUT CAP	TUBE WITH CAP	TAPE & REEL WITHOUT CAP	TAPE & REEL WITH CAP	CKT SIZE	VOID POSITION	PLATING TYPE	A	B	G	F	M
-----	-----	87898-3721	87898-3731	-----	-----	37	-----	1	93.98	91.44	10.81	9.65	5.84
-----	-----	87898-3722	87898-3732	-----	-----	37	-----	2	93.98	91.44	10.81	9.65	5.84
-----	-----	87898-3724	87898-3734	-----	-----	37	-----	4	93.98	91.44	10.81	9.65	5.84
-----	-----	87898-3725	87898-3735	-----	-----	37	-----	5	93.98	91.44	10.81	9.65	5.84
-----	-----	87898-3726	87898-3736	-----	-----	37	-----	6	93.98	91.44	10.81	9.65	5.84
-----	-----	87898-3821	87898-3831	-----	-----	38	-----	1	96.52	93.98	10.81	9.65	5.84
-----	-----	87898-3822	87898-3832	-----	-----	38	-----	2	96.52	93.98	10.81	9.65	5.84
-----	-----	87898-3824	87898-3834	-----	-----	38	-----	4	96.52	93.98	10.81	9.65	5.84
-----	-----	87898-3825	87898-3835	-----	-----	38	-----	5	96.52	93.98	10.81	9.65	5.84
-----	-----	87898-3826	87898-3836	-----	-----	38	-----	6	96.52	93.98	10.81	9.65	5.84
-----	-----	87898-3921	87898-3931	-----	-----	39	-----	1	99.06	96.52	10.81	9.65	5.84
-----	-----	87898-3922	87898-3932	-----	-----	39	-----	2	99.06	96.52	10.81	9.65	5.84
-----	-----	87898-3924	87898-3934	-----	-----	39	-----	4	99.06	96.52	10.81	9.65	5.84
-----	-----	87898-3925	87898-3935	-----	-----	39	-----	5	99.06	96.52	10.81	9.65	5.84
-----	-----	87898-3926	87898-3936	-----	-----	39	-----	6	99.06	96.52	10.81	9.65	5.84

THIS DRAWING CONTAINS INFORMATION THAT IS PROPRIETARY TO MOLEX ELECTRONIC TECHNOLOGIES, LLC AND SHOULD NOT BE USED WITHOUT WRITTEN PERMISSION

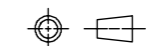
ADD -0318 & -0458 EC NO: 168622 DRWN: FCSCC CHK'D: CGOH REV APPR: KHLIM	2017/11/27	2017/11/27	2017/12/12	GENERAL TOLERANCES (UNLESS SPECIFIED)		DIMENSION UNITS		SCALE		 <b>CUSTOM HEADER</b> 2.54MM PITCH SINGLE ROW SINGLE WAFER SMT HEADER			
	MM		INCH		MM		NTS						
	4 PLACES	±	±	DRWN BY		DATE		YLQIAO		2005/03/14		<b>PRODUCT CUSTOMER DRAWING</b> SERIES: 87898 MATERIAL NUMBER: SEE TABLE CUSTOMER: GENERAL MARKET	
	3 PLACES	±	±	CHK'D BY		DATE		PTLIM		2005/03/29			
	2 PLACES	±	0.2	APPR BY		DATE		MLONG		2010/10/04			
	1 PLACES	±	±	DRAWING SIZE		THIRD ANGLE PROJECTION		A3					
	0 PLACES	±	±	DRAFT WHERE APPLICABLE MUST REMAIN WITHIN DIMENSIONS									
	ANGULAR TOL = 3.0				DRAWING SIZE		THIRD ANGLE PROJECTION		A3		DOCUMENT NUMBER: SD-87898-001 DOC TYPE: PSD DOC PART: 000 SHEET NUMBER: 14 OF 21		
	DRAFT WHERE APPLICABLE MUST REMAIN WITHIN DIMENSIONS												

RELEASE STATUS	RELEASE DATE
----------------	--------------

9

8

7

6

5

4

3

2

1

FORMA: Met-lega-master-ib-prod-A3  
REVISION: C  
DATE: 2016/02/04

9

8

7

6

5

4

3

2

1

PACKAGING OPTION PART NO.

TRAY WITHOUT CAP	TRAY WITH CAP	TUBE		TAPE & REEL		CKT SIZE	VOID POSITION	PLATING TYPE	DIMENSION				
		WITHOUT CAP	WITH CAP	WITHOUT CAP	WITH CAP				A	B	G	F	M
-----	-----	87898-4021	87898-4031	-----	-----	40	-----	1	101.60	99.06	10.81	9.65	5.84
-----	-----	87898-4022	87898-4032	-----	-----	40	-----	2	101.60	99.06	10.81	9.65	5.84
-----	-----	87898-4024	87898-4034	-----	-----	40	-----	4	101.60	99.06	10.81	9.65	5.84
-----	-----	87898-4025	87898-4035	-----	-----	40	-----	5	101.60	99.06	10.81	9.65	5.84
-----	-----	87898-4026	87898-4036	-----	-----	40	-----	6	101.60	99.06	10.81	9.65	5.84

THIS DRAWING CONTAINS INFORMATION THAT IS PROPRIETARY TO MOLEX ELECTRONIC TECHNOLOGIES, LLC AND SHOULD NOT BE USED WITHOUT WRITTEN PERMISSION

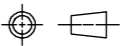
ADD -0318 & -0458 EC NO: 168622 DRWN: FCSCC CHK'D: CGOH REV APPR: KHLIM	2017/11/27		2017/11/27		2017/12/12		GENERAL TOLERANCES (UNLESS SPECIFIED)		DIMENSION UNITS		SCALE									
									MM		NTS									
							4 PLACES ±		MM		INCH		DRWN BY		DATE		CUSTOM HEADER 2.54MM PITCH SINGLE ROW SINGLE WAFER SMT HEADER			
							3 PLACES ±		YLQIAO		2005/03/14		CHK'D BY		DATE					
							2 PLACES ± 0.2		PTLIM		2005/03/29		APPR BY		DATE					
							1 PLACES ±		MLONG		2010/10/04		DRAWING SIZE		THIRD ANGLE PROJECTION		PRODUCT CUSTOMER DRAWING SERIES: 87898    MATERIAL NUMBER: SEE TABLE    CUSTOMER: GENERAL MARKET			
							0 PLACES ±		A3				DOCUMENT NUMBER		DOC TYPE					DOC PART
							ANGULAR TOL = 3.0		DRAFT WHERE APPLICABLE MUST REMAIN WITHIN DIMENSIONS		SD-87898-001		PSD		000		15 OF 21			

RELEASE STATUS	RELEASE DATE
----------------	--------------

9

8

7

6

5

4

3

2

1

FORMA: Met-lega-master-ib-prod-A3  
REVISION: C  
DATE: 2016/02/04

9 8 7 6 5 4 3 2 1

E

PART WITHOUT CAP  
IN TUBE ORIENTATION

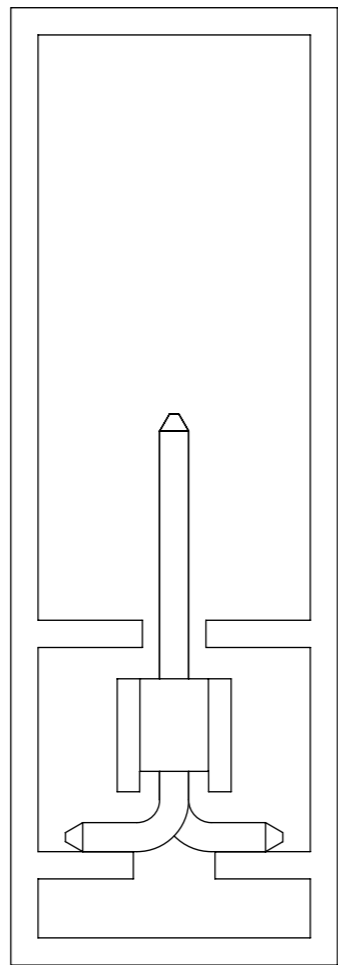

PART WITH CAP  
IN TUBE ORIENTATION

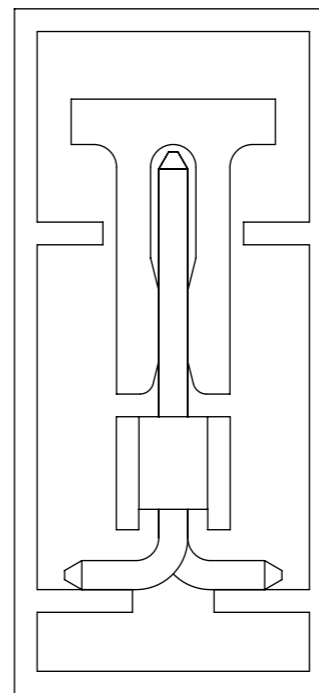

D

C

B

A

THIS DRAWING CONTAINS INFORMATION THAT IS PROPRIETARY TO MOLEX ELECTRONIC TECHNOLOGIES, LLC AND SHOULD NOT BE USED WITHOUT WRITTEN PERMISSION

ADD -0318 & -0458 EC NO: 168622 DRWN: FCSCC CHK'D: CGOH REV APPR: KHLIM	2017/11/27	2017/11/27	GENERAL TOLERANCES (UNLESS SPECIFIED)		DIMENSION UNITS		SCALE						
			MM	INCH	MM	NTS							
	4 PLACES	±	±	DRWN BY	DATE	YLQIAO		2005/03/14		CUSTOM HEADER 2.54MM PITCH SINGLE ROW SINGLE WAFER SMT HEADER			
	3 PLACES	±	±	CHK'D BY	DATE								
	2 PLACES	±	0.2	±	PTLIM	DATE	2005/03/29		PRODUCT CUSTOMER DRAWING				
	1 PLACES	±	±	APPR BY	DATE	MLONG		2010/10/04					
0 PLACES	±	±	ANGULAR TOL = 3.0		DRAWING SIZE	THIRD ANGLE PROJECTION		SERIES	MATERIAL NUMBER	CUSTOMER			
DRAFT WHERE APPLICABLE MUST REMAIN WITHIN DIMENSIONS		A3				87898	SEE TABLE	GENERAL MARKET					
RELEASE STATUS	RELEASE DATE	B19				DOCUMENT NUMBER	DOC TYPE	DOC PART	SHEET NUMBER				
				SD-87898-001	PSD	000	16 OF 21						

RELEASE STATUS	RELEASE DATE
----------------	--------------

9 8 7 6 5 4 3 2 1

FORMA: Met-lega-master-tp-prod-A3  
REVISION: C  
DATE: 2016/02/04



EMBOSED CARRIER TYPE 'A'

CKT	DIMENSION				
	Bo	Ao	Ko	F	W
2	8.02	5.20	13.60	11.50	24.00
3	8.02	5.20	13.60	11.50	24.00
4	10.55	5.20	13.60	11.50	24.00

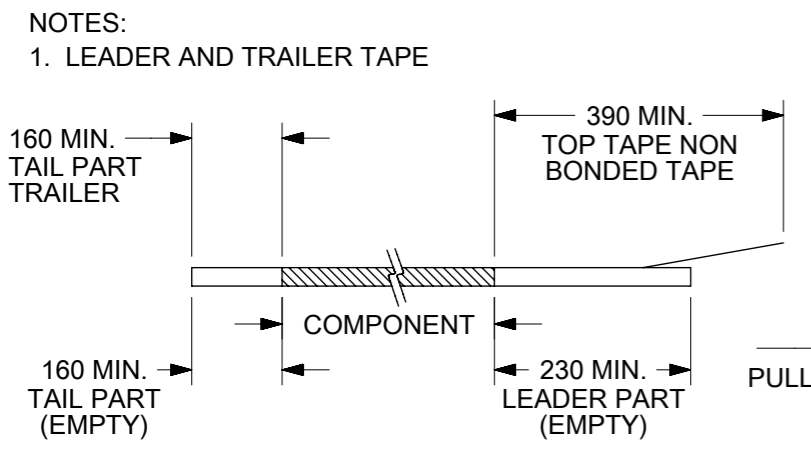
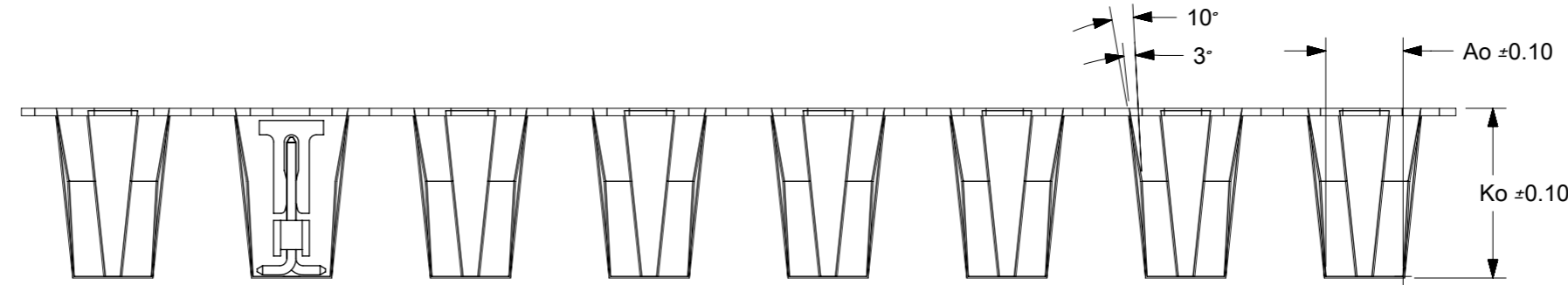
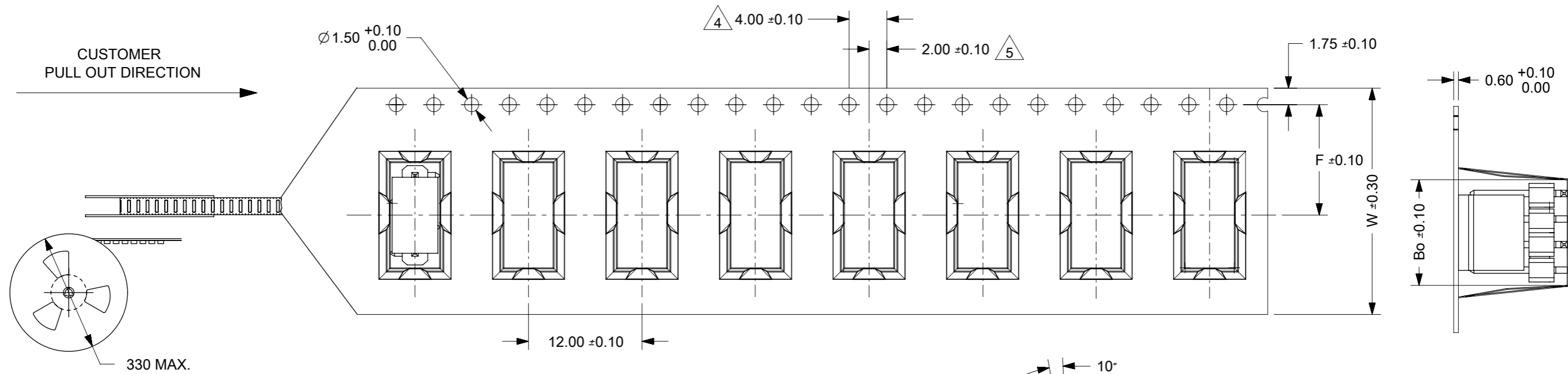

PART PACK IN E/TAPE ORIENTATION (FOR REF USE)

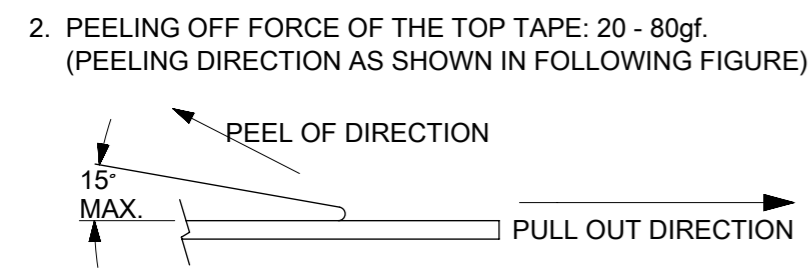

3. MATERIAL: BLACK P.S CONDUCTIVE, BLACK
4. MEASURED FROM CENTRELINE OF SPROCKET HOLE TO CENTRELINE OF SPOCKET
5. CUMULATIVE TOLERANCE OF 10 SPROCKET HOLE IS  $\pm 0.20\text{mm}$
6. A0 AND B0 ARE MEASURE FROM ABOVE POCKET BASE 0.30mm
7. TAPE AND REEL SPECIFICATION IS AS PER EIA-481.
8. TAPE AND REEL QUANTITY : 440PCS/REEL
9. THE TAPE IS TREATED FOR ANTI-STATIC.
10. ALL RADIUS ARE 0.30MM UNLESS SPECIFY
11. SURFACE RESISTIVITY  $10^3$  TO  $10^4$  OHMS.

THIS DRAWING CONTAINS INFORMATION THAT IS PROPRIETARY TO MOLEX ELECTRONIC TECHNOLOGIES, LLC AND SHOULD NOT BE USED WITHOUT WRITTEN PERMISSION

ADD -0318 & -0458 EC NO: 168622 DRWN: FCSCC CHKD: CGOH REV APPR: KHLIM	2017/11/27	2017/11/27	2017/12/12	GENERAL TOLERANCES (UNLESS SPECIFIED)		DIMENSION UNITS	SCALE			
	4 PLACES		$\pm$	$\pm$	MM	NTS				
	3 PLACES		$\pm$	$\pm$	DRWN BY	DATE	CUSTOM HEADER 2.54MM PITCH SINGLE ROW SINGLE WAFER SMT HEADER			
	2 PLACES		$\pm 0.2$	$\pm$	YLQIAO	2005/03/14				
	1 PLACES		$\pm$	$\pm$	CHK'D BY	DATE				PRODUCT CUSTOMER DRAWING
0 PLACES		$\pm$	$\pm$	PTLIM	2005/03/29					
ANGULAR TOL = 3.0		DRAFT WHERE APPLICABLE MUST REMAIN WITHIN DIMENSIONS		APPR BY	DATE	SERIES	MATERIAL NUMBER	CUSTOMER	87898 SEE TABLE GENERAL MARKET	
A3		THIRD ANGLE PROJECTION		MLONG	2010/10/04	78798	SEE TABLE	GENERAL MARKET		
B19		REV		DRAWING SIZE		DOCUMENT NUMBER		DOC TYPE	DOC PART	SHEET NUMBER
				A3		SD-87898-001		PSD	000	17 OF 21

RELEASE STATUS	RELEASE DATE
----------------	--------------

CKT	DIMENSION				
	Bo	Ao	Ko	F	W
5	13.10	5.20	11.30	11.50	24.00

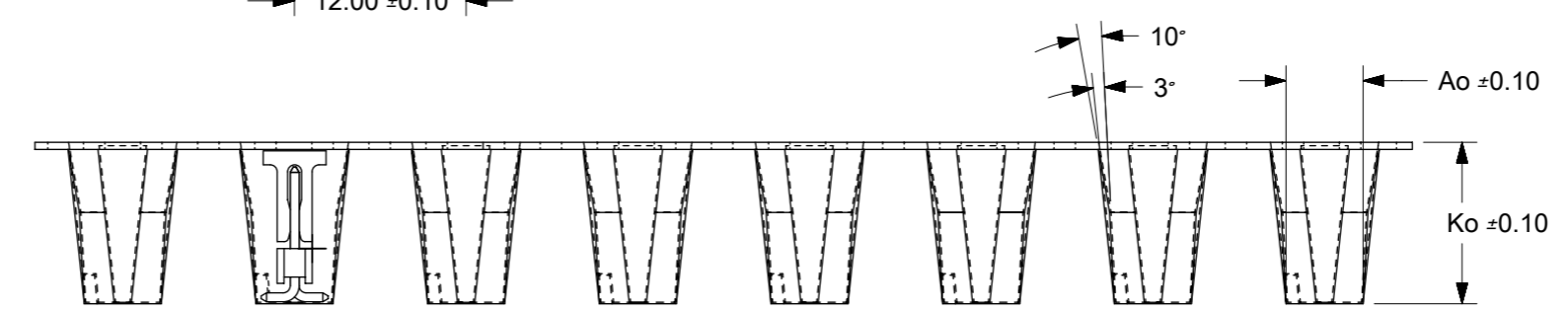
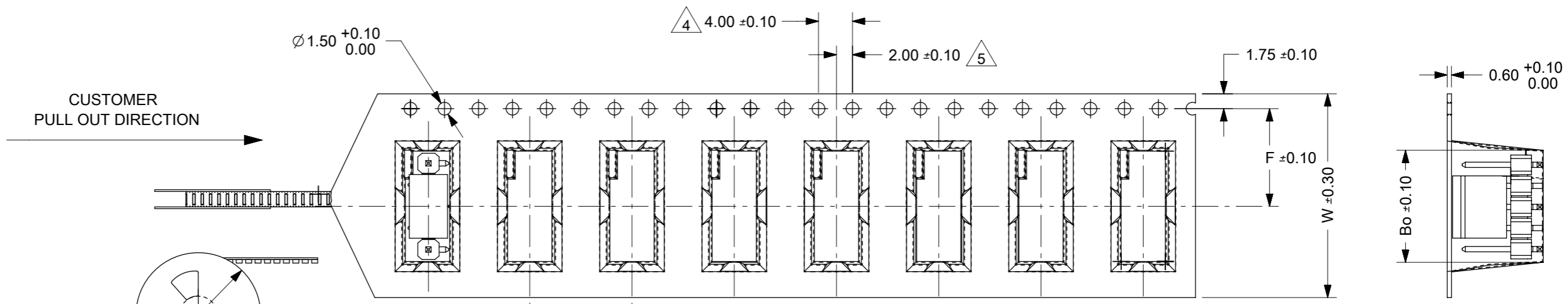

NOTES:  
1. LEADER AND TRAILER TAPE

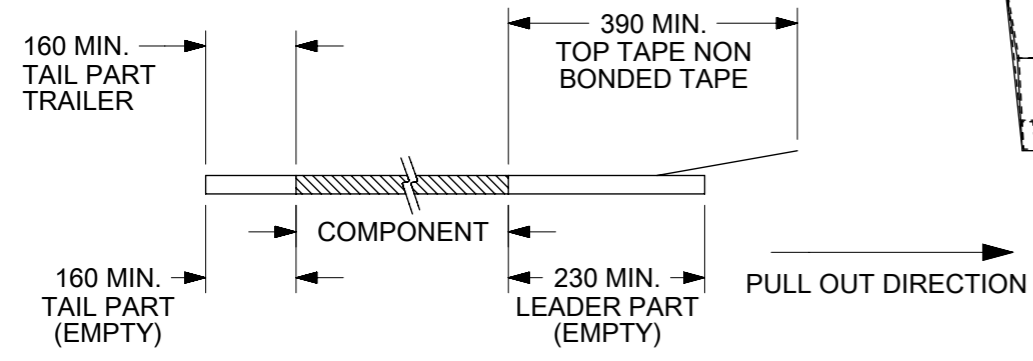

2. PEELING OFF FORCE OF THE TOP TAPE: 20 - 80gf.  
(PEELING DIRECTION AS SHOWN IN FOLLOWING FIGURE)

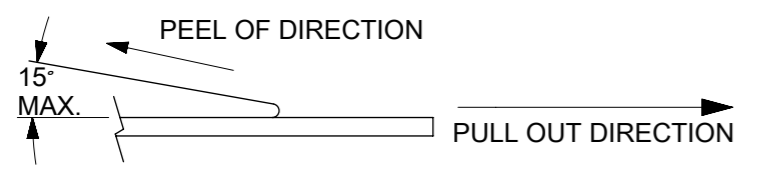

- 3. MATERIAL: BLACK P.S CONDUCTIVE, BLACK
- 4. MEASURED FROM CENTRELINE OF SPROCKET HOLE TO CENTRELINE OF SPOCKET
- 5. CUMULATIVE TOLERANCE OF 10 SPROCKET HOLE IS ±0.20mm
- 6. A0 AND B0 ARE MEASURE FROM ABOVE POCKET BASE 0.30mm
- 7. TAPE AND REEL SPECIFICATION IS AS PER EIA-481.
- 8. TAPE AND REEL QUANTITY : 440PCS/REEL
- 9. THE TAPE IS TREATED FOR ANTI-STATIC.
- 10. ALL RADIUS ARE 0.30MM UNLESS SPECIFY
- 11. SURFACE RESISTIVITY 10<sup>3</sup> TO 10 OHMS.

THIS DRAWING CONTAINS INFORMATION THAT IS PROPRIETARY TO MOLEX ELECTRONIC TECHNOLOGIES, LLC AND SHOULD NOT BE USED WITHOUT WRITTEN PERMISSION

ADD -0318 & -0458 EC NO: 168622 DRWN: FCSCC CHK'D: CGOH REV APPR: KHLIM	2017/11/27	2017/11/27	2017/12/12	GENERAL TOLERANCES (UNLESS SPECIFIED)		DIMENSION UNITS	SCALE					
				MM	INCH	MM	NTS					
				4 PLACES	±	±	DRWN BY	DATE	<b>CUSTOM HEADER</b> <b>2.54MM PITCH SINGLE ROW SINGLE WAFER SMT HEADER</b>			
				3 PLACES	±	±	YLQIAO	2005/03/14				
				2 PLACES	±	0.2	±	CHK'D BY	DATE	<b>PRODUCT CUSTOMER DRAWING</b>		
			1 PLACES	±	±	PTLIM	2005/03/29					
			0 PLACES	±	±	APPR BY	DATE	<b>GENERAL MARKET</b>				
						MLONG	2010/10/04					
						ANGULAR TOL = 3.0	DRAWING SIZE	THIRD ANGLE PROJECTION	SERIES	MATERIAL NUMBER	CUSTOMER	
						DRAFT WHERE APPLICABLE MUST REMAIN WITHIN DIMENSIONS	A3		87898	SEE TABLE	GENERAL MARKET	
									DOCUMENT NUMBER	DOC TYPE	DOC PART	SHEET NUMBER
									SD-87898-001	PSD	000	18 OF 21

RELEASE STATUS	RELEASE DATE
----------------	--------------

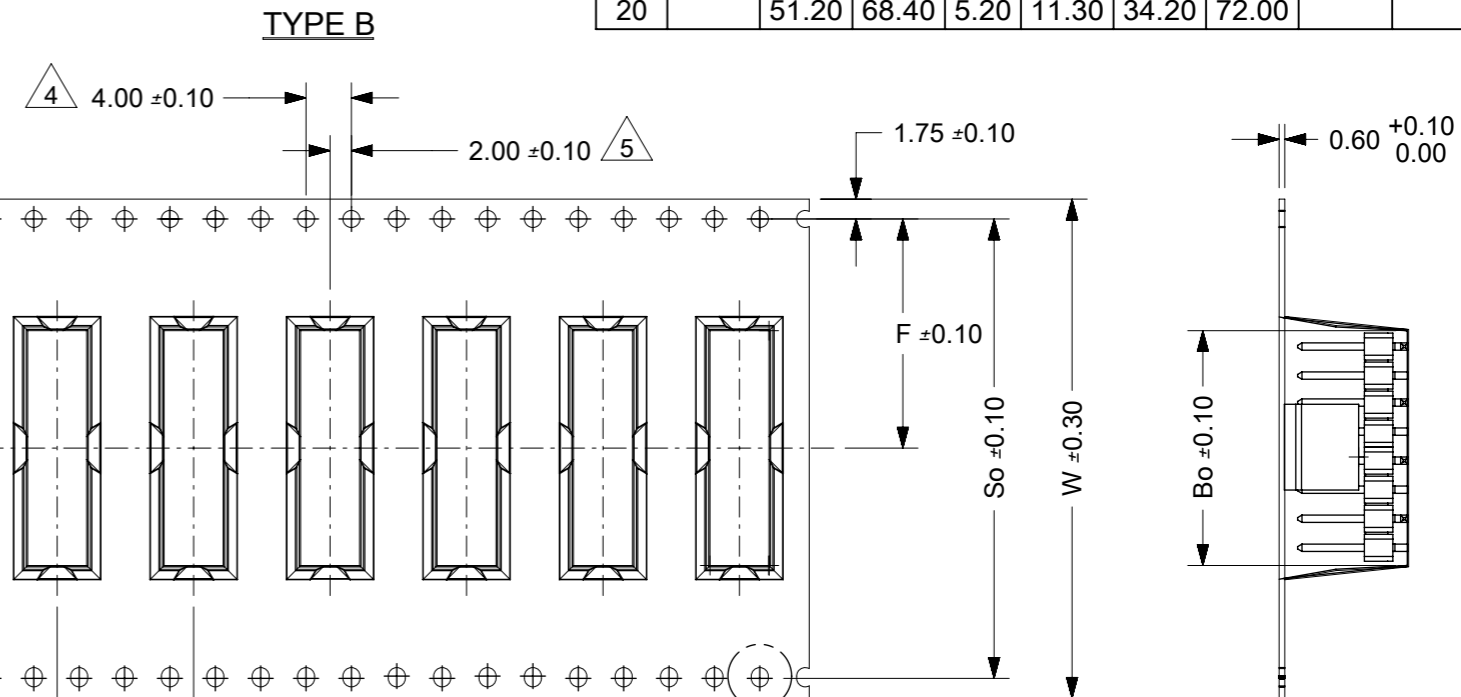
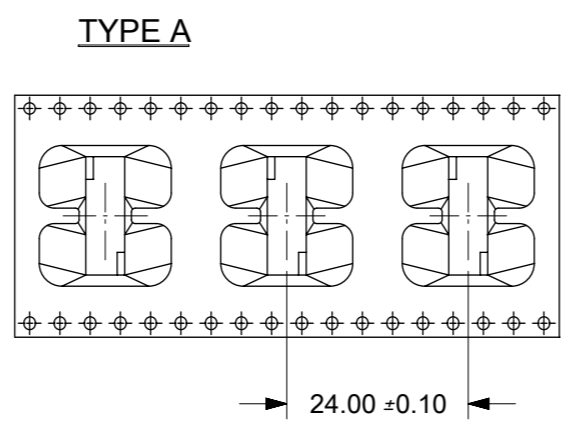
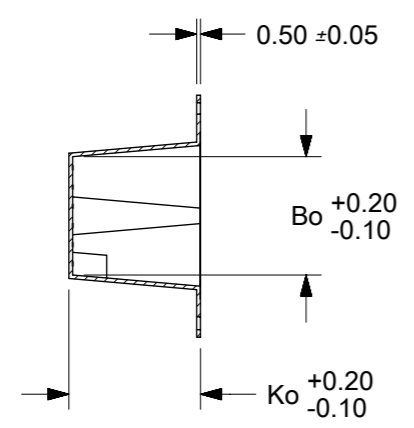

CKT	DIMENSION							TYPE	QTY/ REEL
	M	Bo	So	Ao	Ko	F	W		
6	11.50	15.65	28.40	5.20	16.90	14.20	32.00	A	150
6	5.84	15.65	28.40	5.20	11.30	14.20	32.00	B	440
8		20.70	40.40	5.20	11.30	20.20	44.00		
10		25.80	40.40	5.20	11.30	20.20	44.00		
12		30.90	52.40	5.20	11.30	26.20	56.00		
14		35.95	52.40	5.20	11.30	26.20	56.00		
16		41.05	52.40	5.20	11.30	26.20	56.00		
18		46.20	68.40	5.20	11.30	34.20	72.00		
20		51.20	68.40	5.20	11.30	34.20	72.00		

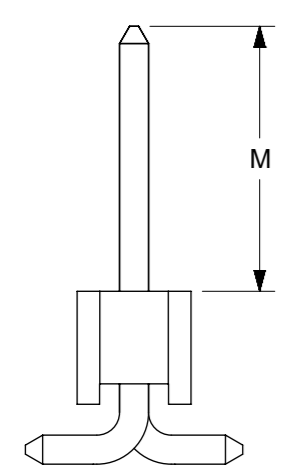

NOTES:  
1. LEADER AND TRAILER TAPE

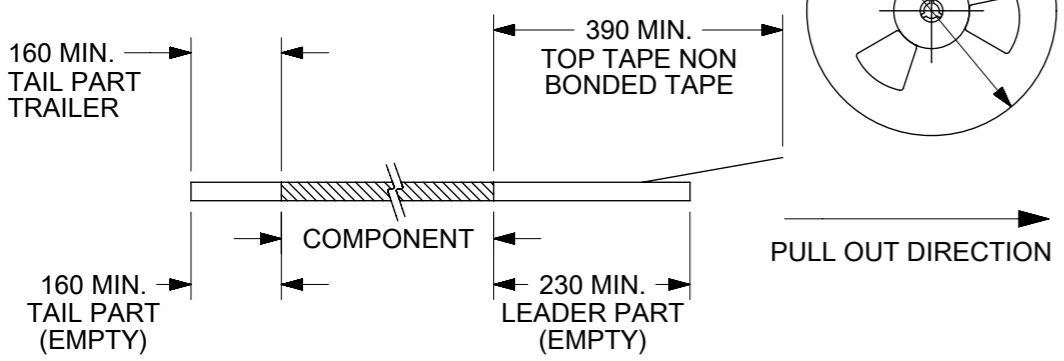

2. PEELING OFF FORCE OF THE TOP TAPE: 20 - 80gf.  
(PEELING DIRECTION AS SHOWN IN FOLLOWING FIGURE)

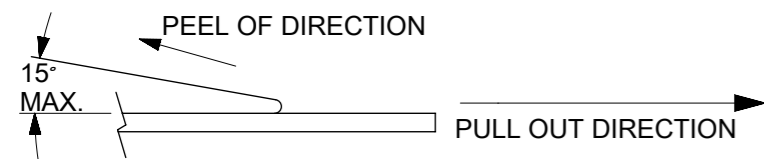

3. MATERIAL: BLACK P.S CONDUCTIVE, BLACK

4. MEASURED FROM CENTRELINE OF SPROCKET HOLE TO CENTRELINE OF SPOCKET

5. CUMULATIVE TOLERANCE OF 10 SPROCKET HOLE IS ±0.20mm

6. A0 AND B0 ARE MEASURE FROM ABOVE POCKET BASE 0.30mm

7. TAPE AND REEL SPECIFICATION IS AS PER EIA-481.

8. TAPE AND REEL QUANTITY : SEE TABLE

9. THE TAPE IS TREATED FOR ANTI-STATIC.

10. ALL RADIUS ARE 0.30MM UNLESS SPECIFY

11. SURFACE RESISTIVITY 10<sup>3</sup> TO 10 OHMS.

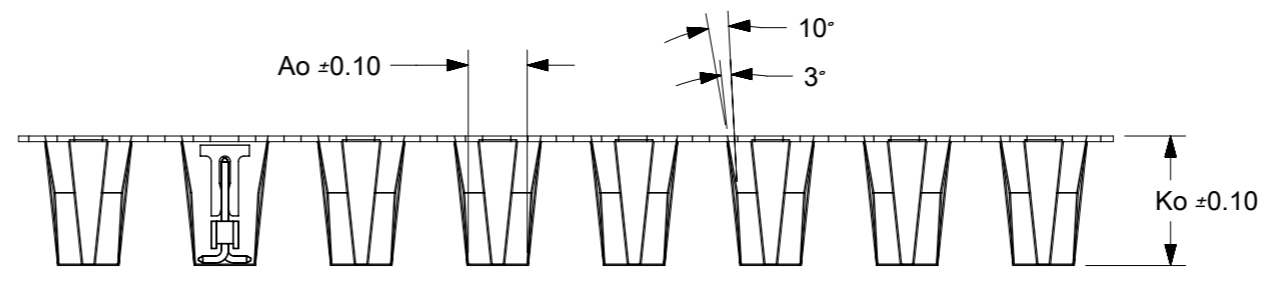

PART PACK IN E/TAPE ORIENTATION(FOR REF USE)

THIS DRAWING CONTAINS INFORMATION THAT IS PROPRIETARY TO MOLEX ELECTRONIC TECHNOLOGIES, LLC AND SHOULD NOT BE USED WITHOUT WRITTEN PERMISSION

ADD -0318 & -0458 EC NO: 168622 DRWN: FCSCC CHKD: CGOH APPR: KHLIM	2017/11/27	GENERAL TOLERANCES (UNLESS SPECIFIED)		DIMENSION UNITS	SCALE		
	2017/11/27	MM	INCH	MM	NTS		
	2017/12/12	4 PLACES ±	±	DRWN BY	DATE		<b>CUSTOM HEADER</b> <b>2.54MM PITCH SINGLE ROW SINGLE WAFER SMT HEADER</b>
		3 PLACES ±	±	YLQIAO	2005/03/14		
		2 PLACES ±	0.2	±	CHK'D BY		
	1 PLACES ±	±	±	PTLIM	2005/03/29		
	0 PLACES ±	±	±	APPR BY	DATE		
		ANGULAR TOL = 3.0		MLONG	2010/10/04	PRODUCT CUSTOMER DRAWING	
		DRAFT WHERE APPLICABLE MUST REMAIN WITHIN DIMENSIONS		DRAWING SIZE	THIRD ANGLE PROJECTION	SERIES	
				A3		87898	
						MATERIAL NUMBER	
						SEE TABLE	
						CUSTOMER	
						GENERAL MARKET	
						DOCUMENT NUMBER	
						SD-87898-001	
						DOC TYPE	
						PSD	
						DOC PART	
						000	
						SHEET NUMBER	
						19 OF 21	

RELEASE STATUS	RELEASE DATE
----------------	--------------

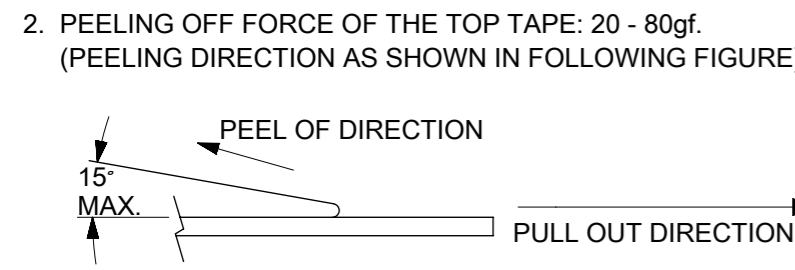
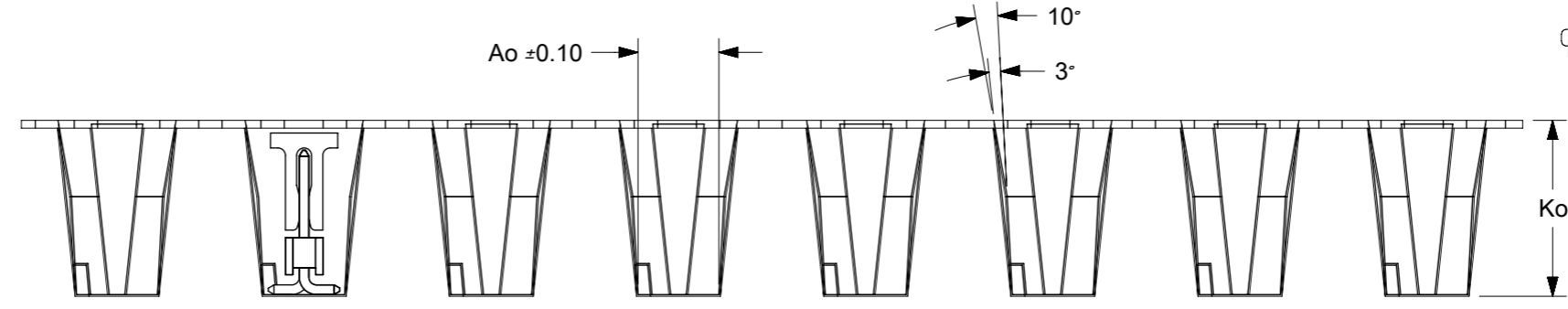
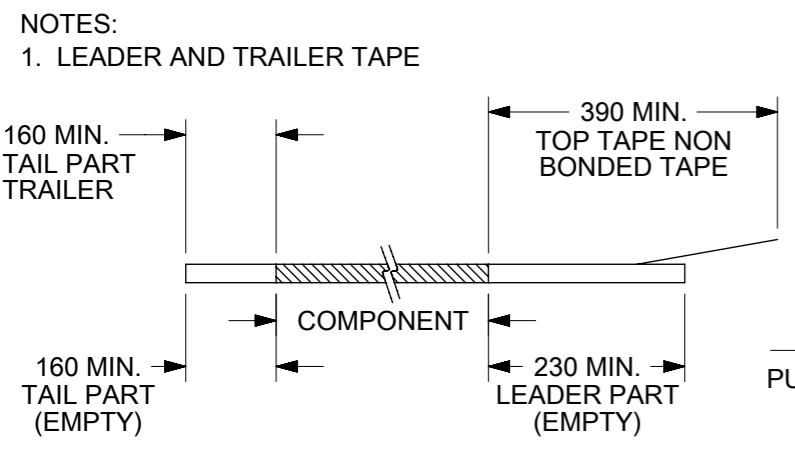
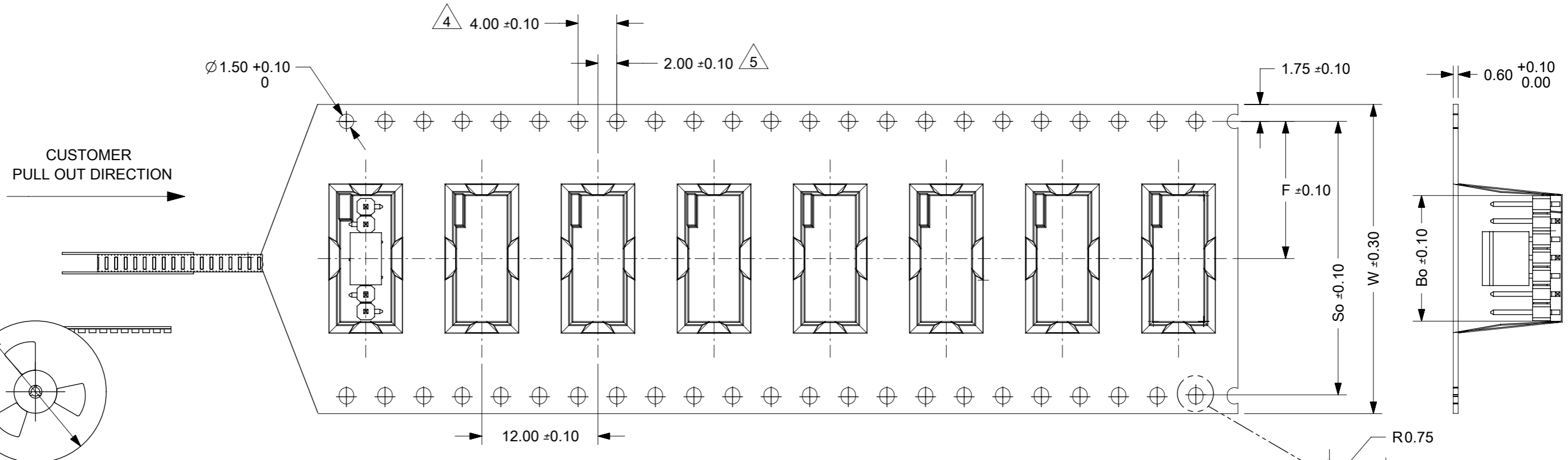

- NOTES:
- LEADER AND TRAILER TAPE
  - PEELING OFF FORCE OF THE TOP TAPE: 20 - 80gf. (PEELING DIRECTION AS SHOWN IN FOLLOWING FIGURE)
  - MATERIAL: BLACK P.S CONDUCTIVE, BLACK
  - MEASURED FROM CENTRELINE OF SPROCKET HOLE TO CENTRELINE OF SPOCKET
  - CUMULATIVE TOLERANCE OF 10 SPROCKET HOLE IS ±0.20mm
  - A0 AND B0 ARE MEASURE FROM ABOVE POCKET BASE 0.30mm
  - TAPE AND REEL SPECIFICATION IS AS PER EIA-481.
  - TAPE AND REEL QUANTITY : 440PCS/REEL
  - THE TAPE IS TREATED FOR ANTI-STATIC.
  - ALL RADIUS ARE 0.30MM UNLESS SPECIFY
  - SURFACE RESISTIVITY 10<sup>3</sup> TO 10 OHMS.

CKT	DIMENSION					
	Bo	So	Ao	Ko	F	W
7	18.20	40.40	5.20	11.30	20.20	44.00
9	23.25	40.40	5.20	11.30	20.20	44.00
11	28.35	40.40	5.20	11.30	20.20	44.00
13	33.40	52.40	5.20	11.30	26.20	56.00
15	38.50	52.40	5.20	11.30	26.20	56.00
17	43.60	68.40	5.20	11.30	34.20	72.00
19	48.70	68.40	5.20	11.30	34.20	72.00
21	53.80	68.40	5.20	11.30	34.20	72.00

THIS DRAWING CONTAINS INFORMATION THAT IS PROPRIETARY TO MOLEX ELECTRONIC TECHNOLOGIES, LLC AND SHOULD NOT BE USED WITHOUT WRITTEN PERMISSION

ADD -0318 & -0458 EC NO: 168622 DRWN: FCSC0 CHK'D: CGOH REV APPR: KHLIM	2017/11/27	2017/11/27	2017/12/12	GENERAL TOLERANCES (UNLESS SPECIFIED)		DIMENSION UNITS	SCALE			
	MM		INCH		MM	NTS				
	4 PLACES	±	±	YLQIAO	DATE	2005/03/14	CUSTOM HEADER 2.54MM PITCH SINGLE ROW SINGLE WAFER SMT HEADER			
	3 PLACES	±	±	CHK'D BY	DATE					
	2 PLACES	±	0.2	±	PTLIM	DATE	2005/03/29	PRODUCT CUSTOMER DRAWING		
1 PLACES	±	±	APPR BY	DATE						
0 PLACES	±	±	MLONG	DATE	2010/10/04	SERIES: 87898 MATERIAL NUMBER: SEE TABLE CUSTOMER: GENERAL MARKET				
ANGULAR TOL = 3.0		DRAWING SIZE	THIRD ANGLE PROJECTION							
DRAFT WHERE APPLICABLE MUST REMAIN WITHIN DIMENSIONS		A3					DOCUMENT NUMBER: SD-87898-001 DOC TYPE: PSD DOC PART: 000 SHEET NUMBER: 20 OF 21			

RELEASE STATUS	RELEASE DATE
----------------	--------------

PACKAGING OPTION PART NO.						CKT SIZE	PLATING TYPE	DIMENSION		
TRAY WITHOUT CAP	TRAY WITH CAP	TUBE WITHOUT CAP	TUBE WITH CAP	TAPE & REEL WITHOUT CAP	TAPE & REEL WITH CAP			G	F	M
-----	-----	-----	-----	-----	87898-0218	2	4	10.69	9.65	5.84
-----	-----	-----	-----	-----	87898-0219	2	6	10.69	9.65	5.84

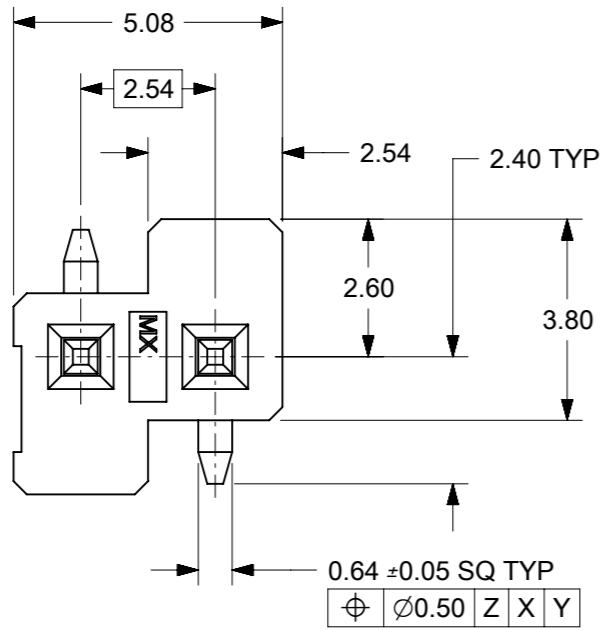

ONLY APPLICABLE TO 2CKT SIZE

- NOTES:
- MATERIAL:
    - HSG: LCP, GLASS-FILLED, UL94V-0, COLOR: BLACK
    - CAP: NYLON, GLASS-FILLED, UL94V-0, COLOR: BLACK
    - PIN: 0.64MM SQ, COPPER ALLOY
  - PLATING TYPE:
    - GOLD FLASH OVER  
1.25µm MIN. NICKEL OVERALL.
    - GOLD FLASH ON CONTACT AND  
2.50µm MIN. TIN ON SOLDER TAIL OVER  
1.25µm MIN. NICKEL OVERALL.
    - 0.38µm MIN. GOLD PLATE ON CONTACT AND  
2.00µm MIN. TIN ON SOLDER TAIL OVER  
1.25µm MIN. NICKEL OVERALL.
    - 0.75µm MIN. GOLD PLATE ON CONTACT AND  
2.00µm MIN. TIN ON SOLDER TAIL OVER  
1.25µm MIN. NICKEL OVERALL.
    - 2.50µm MIN. TIN OVERALL  
1.25µm MIN. NICKEL OVERALL
  - PRODUCT SPECIFICATION: PS-87920-019
  - PACKAGING TYPE: SEE TABLE
  - PACKAGING SPEC:
    - TUBE WITH CAP VERSION: PK-89990-558
    - TUBE W/O CAP VERSION: PK-89990-545
    - EMBOSS TAPE WITH CAP: PK-87898-400
  - WAFER TO BE FLAT WITHIN 0.003 mm/mm
  - BEND DEPRESSION IS ACCEPTED SO LONG AS IT DOES NOT AFFECT THE OVERALL COPLANARITY OF TAIL
  - COPLANARITY IS TO BE MEASURED BY RESTING THE SOLDER TAIL ON A FLAT SURFACE
  - CAP LOCATION IS CENTERED ALONG THE MATING ENDS AS SHOWN. TOP SURFACE OF CAP TO BE FLAT FOR THE PURPOSE OF PICK & PLACE BY VACUUM SUCTION NOZZLE
  - RECOMMENDED PCB THICKNESS IS 1.60mm±0.10

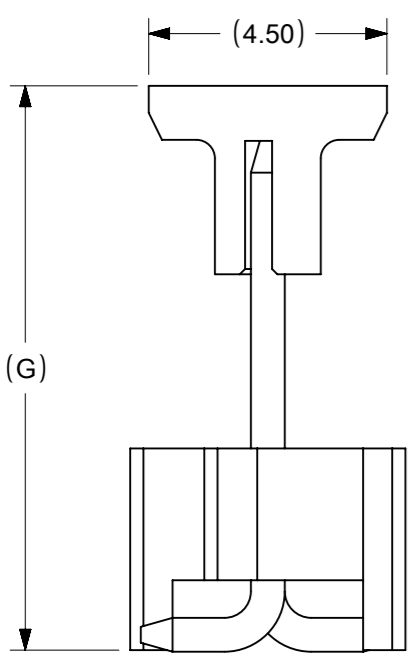
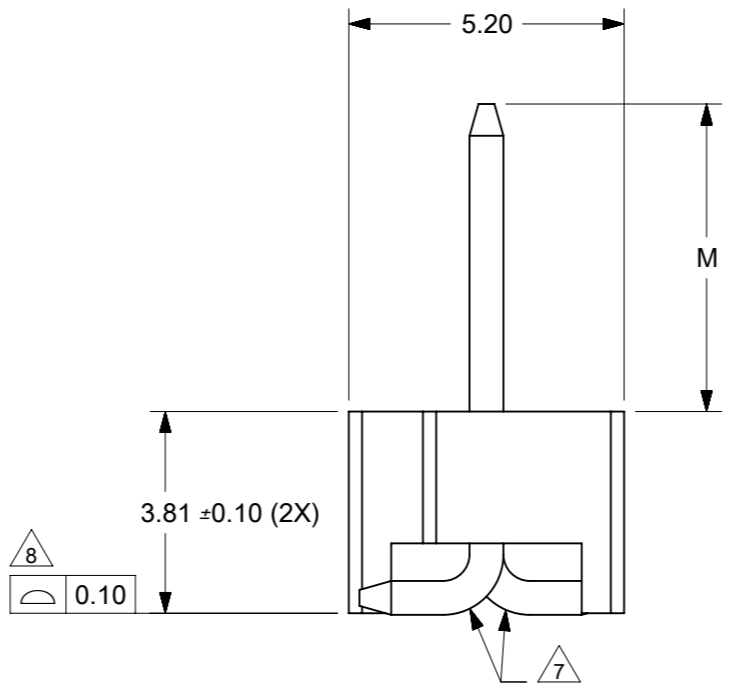
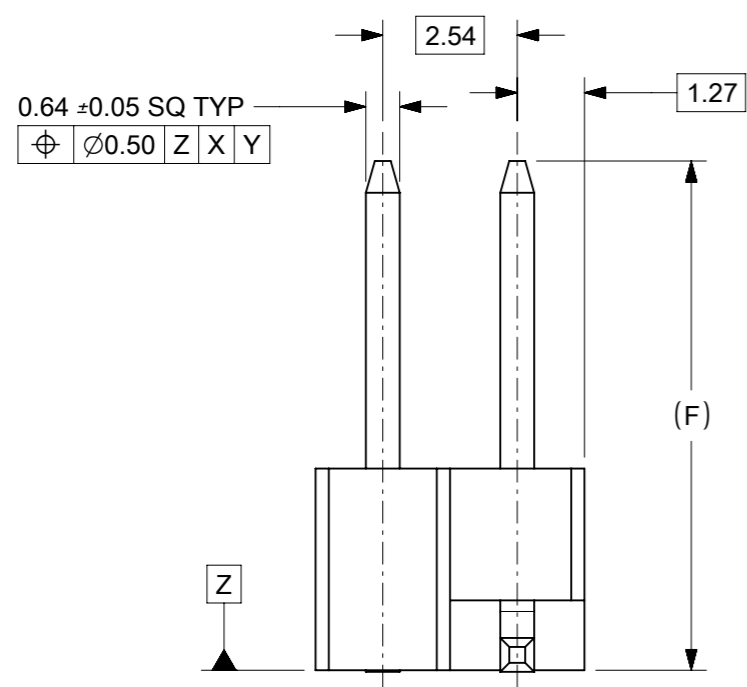

CONN WITH CAP

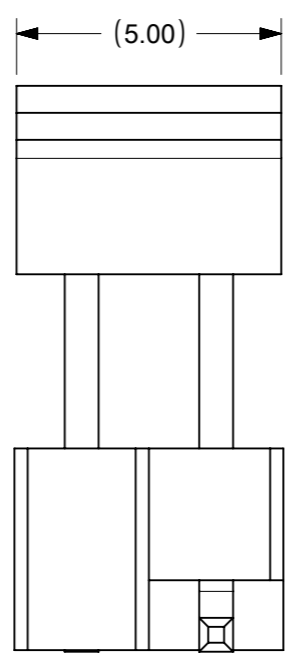

CONN WITH CAP

THIS DRAWING CONTAINS INFORMATION THAT IS PROPRIETARY TO MOLEX ELECTRONIC TECHNOLOGIES, LLC AND SHOULD NOT BE USED WITHOUT WRITTEN PERMISSION

ADD -0318 & -0458	2017/11/27	GENERAL TOLERANCES (UNLESS SPECIFIED)	DIMENSION UNITS		SCALE		<b>molex</b>	
	2017/11/27		MM	INCH	MM	NTS		
	2017/12/12		4 PLACES ±	±	DRWN BY	DATE		CUSTOMER DRAWING
	EC NO: 168622		3 PLACES ±	±	YLQIAO	2005/03/14		
DRWN: FCSCC	2 PLACES ± 0.2	±	CHK'D BY	DATE	PRODUCT CUSTOMER DRAWING			
CHK'D: CGOH	1 PLACES ±	±	PTLIM	2005/03/29	SERIES			
REV APPR: KHLIM	0 PLACES ±	±	APPR BY	DATE	MATERIAL NUMBER			
		ANGULAR TOL = 3.0	MLONG	2010/10/04	CUSTOMER			
		DRAFT WHERE APPLICABLE MUST REMAIN WITHIN DIMENSIONS	DRAWING SIZE	THIRD ANGLE PROJECTION	GENERAL MARKET			
B19			A3		DOCUMENT NUMBER			
					SD-87898-001			
					DOC TYPE			
					PSD			
					DOC PART			
					000			
					SHEET NUMBER			
					21 OF 21			

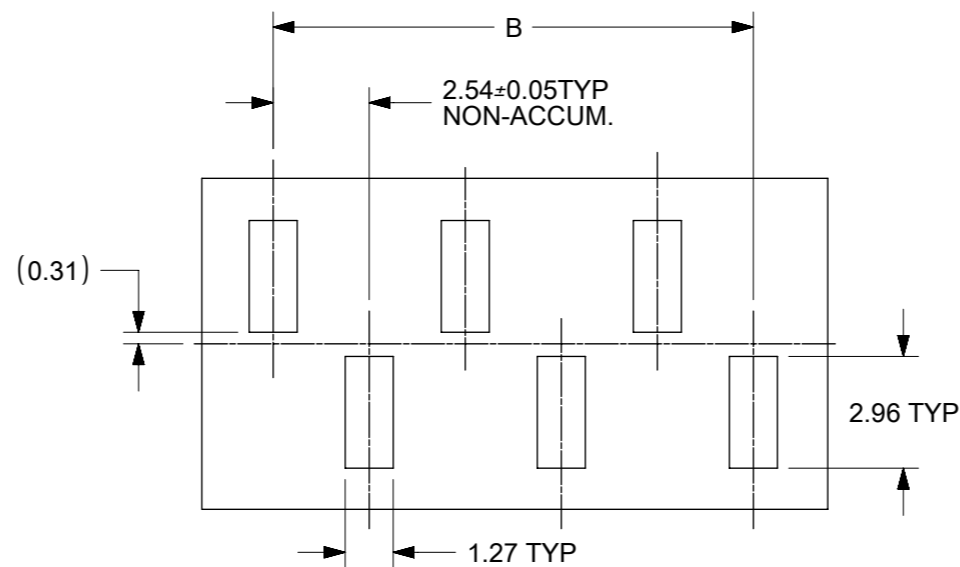
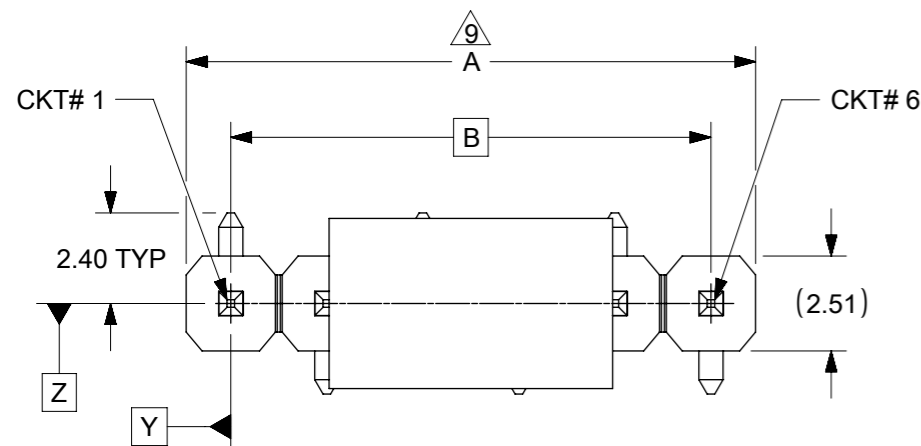

**RECOMMENDED PCB LAYOUT**

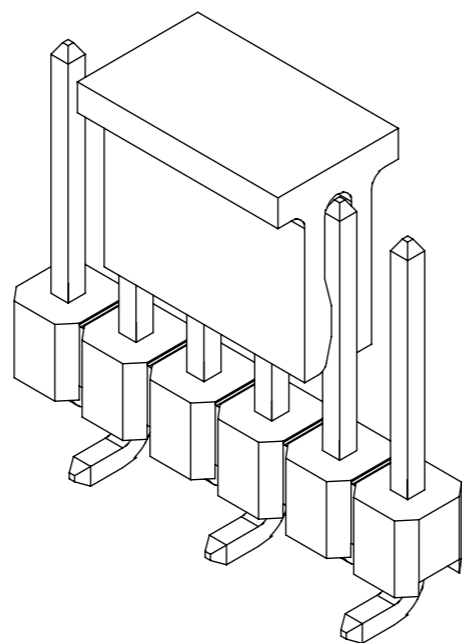
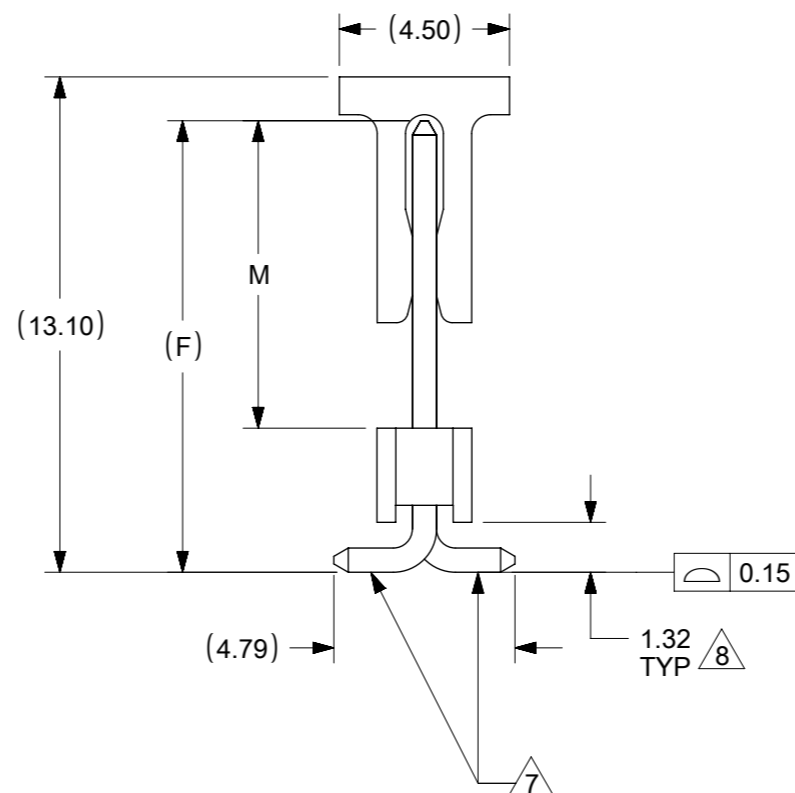
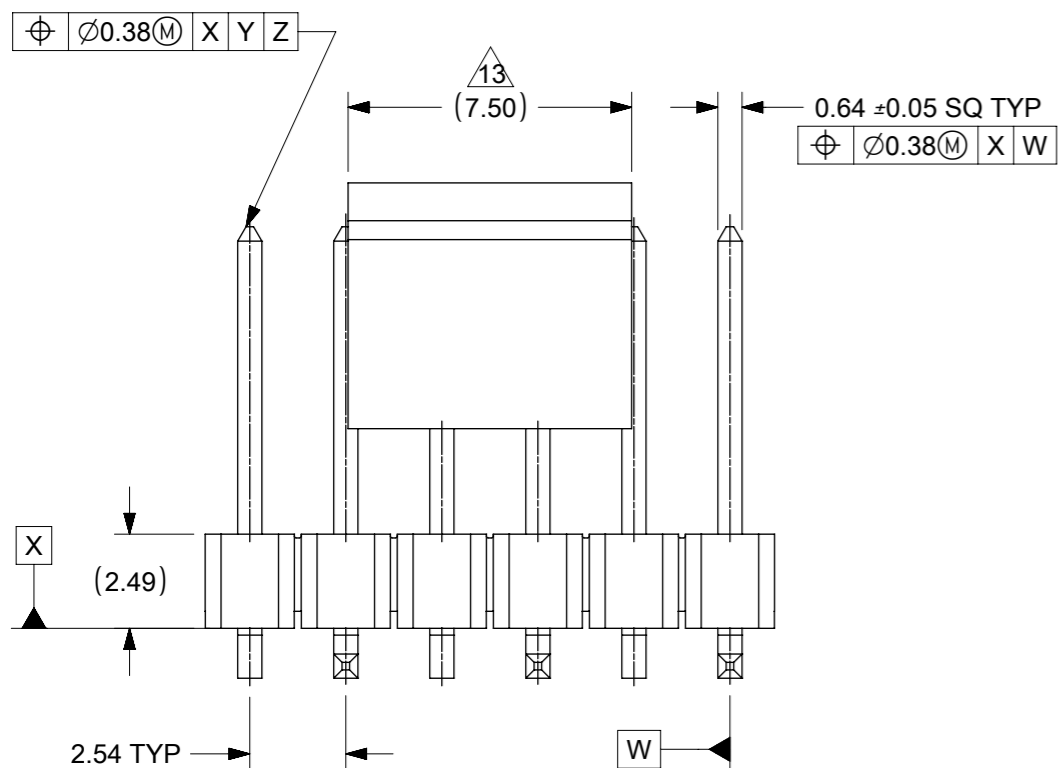

**NOTES:**

1. MATERIAL:  
HSG: NYLON, GLASS-FILLED, UL94V-0, COLOR: BLACK  
PIN: 0.64MM SQ, COPPER ALLOY
2. PLATING TYPE:
  - (1) GOLD FLASH OVER  
1.25µm MIN. NICKEL OVERALL.
  - (2) GOLD FLASH ON CONTACT AND  
2.50µm MIN. TIN ON SOLDER TAIL OVER  
1.25µm MIN. NICKEL OVERALL.
  - (4) 0.38µm MIN. GOLD PLATE ON CONTACT AND  
2.00µm MIN. TIN ON SOLDER TAIL OVER  
1.25µm MIN. NICKEL OVERALL.
  - (5) 0.75µm MIN. GOLD PLATE ON CONTACT AND  
2.00µm MIN. TIN ON SOLDER TAIL OVER  
1.25µm MIN. NICKEL OVERALL.
  - (6) 2.50µm MIN. TIN OVERALL  
1.25µm MIN. NICKEL OVERALL
3. PRODUCT SPECIFICATION: PS-87920-019
4. PACKAGING TYPE: SEE TABLE
5. PACKAGING SPEC: PK-89990-545(TUBE), PK-89990-486(T&R) & PK-87898-400 (T&R)
6. WAFER TO BE FLAT WITHIN 0.003 mm/mm
7. BEND DEPRESSION IS ACCEPTED SO LONG AS IT DOES NOT AFFECT THE OVERALL COPLANARITY OF TAIL
8. COPLANARITY IS TO BE MEASURED BY RESTING THE SOLDER TAIL ON A FLAT SURFACE
9. IRREGULAR CIRCUIT CUTOFF WITHIN BREAKAWAY SECTION IS PERMISSIBLE. CUTTING OR CHIPPING OF THE MAIN BODY IS NOT ACCEPTABLE
10. TUBE LENGTH AS PER STANDARD 560mm
11. RECOMMENDED PCB THICKNESS IS 1.60mm±0.10
12. THE ABOVE CKT 6 IS FOR ILLUSTRATION PURPOSE ONLY
13. CAP LOCATION IS CENTERED ALONG THE MATING ENDS AS SHOWN. TOP SURFACE OF CAP TO BE FLAT FOR THE PURPOSE OF PICK & PLACE BY VACUUM SUCTION NOZZLE.

THIS DRAWING CONTAINS INFORMATION THAT IS PROPRIETARY TO MOLEX ELECTRONIC TECHNOLOGIES, LLC AND SHOULD NOT BE USED WITHOUT WRITTEN PERMISSION		CURRENT REV DESC: SH_04 & 05 UPDATED		<b>molex</b>	
DIMENSION UNITS: mm		SCALE: NTS			
GENERAL TOLERANCES (UNLESS SPECIFIED)				PRODUCT CUSTOMER DRAWING	
				DOCUMENT NUMBER: SD-87898-003	
4 PLACES ±		MM INCH		DOC TYPE: PSD	
3 PLACES ±		EC NO: 177265		DOC PART: 001	
2 PLACES ± 0.2		DRWN: RLALSANGI 2018/05/16		REVISION: C	
1 PLACE ±		CHK'D: MBELLE 2018/05/25			
0 PLACES ±		APPR: ISHWARG 2018/06/13			
ANGULAR TOL ± 3.0°		INITIAL REVISION:			
DRAFT WHERE APPLICABLE MUST REMAIN WITHIN DIMENSIONS		DRWN: SKLIM01 2005/10/26			
THIRD ANGLE PROJECTION		APPR: PTLIM 2005/11/07			
DRAWING: A3-SIZE		SERIES: 87898		MATERIAL NUMBER: SEE TABLE	
		CUSTOMER: GENERAL MARKET		SHEET NUMBER: 1 OF 17	

9 8 7 6 5 4 3 2 1

E  
D  
C  
B  
A

### PART WITHOUT CAP IN TUBE ORIENTATION

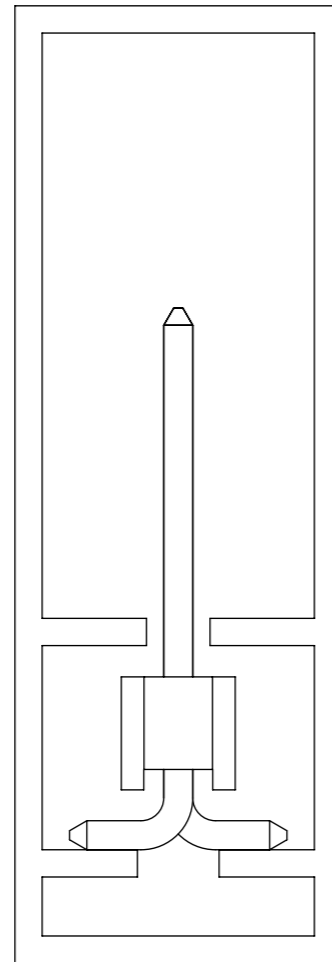

### PART WITH CAP IN TUBE ORIENTATION

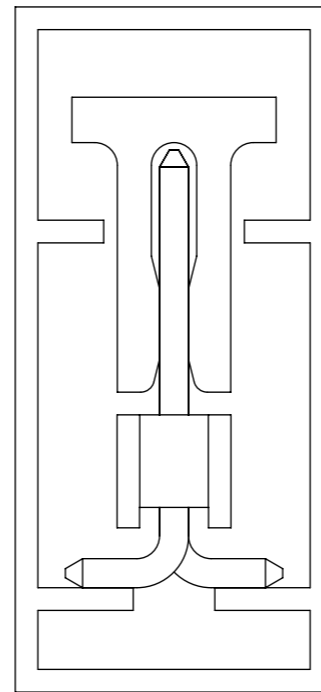

THIS DRAWING CONTAINS INFORMATION THAT IS PROPRIETARY TO MOLEX ELECTRONIC TECHNOLOGIES, LLC AND SHOULD NOT BE USED WITHOUT WRITTEN PERMISSION									
DIMENSION UNITS		SCALE		CURRENT REV DESC: SH_04 & 05 UPDATED				<b>molex</b>	
mm		NTS							
GENERAL TOLERANCES (UNLESS SPECIFIED)				EC NO: 177265				CUSTOM HEADER 2.54MM PITCH SINGLE ROW SINGLE WAFER SMT HEADER	
		MM	INCH	DRWN: RLALSANGI		2018/05/16			
4 PLACES		±	±	CHK'D: MBELLE		2018/05/25		PRODUCT CUSTOMER DRAWING	
3 PLACES		±	±	APPR: ISHWARG		2018/06/13			
2 PLACES		±	0.2	INITIAL REVISION:				DOCUMENT NUMBER	
1 PLACE		±	±	DRWN: SKLIM01		2005/10/26		SD-87898-003	
0 PLACES		±	±	APPR: PTLIM		2005/11/07		DOC TYPE	
ANGULAR TOL		± 3.0°		DRAWING		SERIES		REVISION	
DRAFT WHERE APPLICABLE MUST REMAIN WITHIN DIMENSIONS		THIRD ANGLE PROJECTION		DRAWING		SERIES		MATERIAL NUMBER	
				A3-SIZE		87898		CUSTOMER	
				SEE TABLE		GENERAL MARKET		SHEET NUMBER	
								2 OF 17	

DOCUMENT STATUS	P1	RELEASE DATE	2018/06/13	11:06:55
-----------------	----	--------------	------------	----------

9 8 7 6 5 4 3 2 1

CKT	DIMENSION						QTY/REEL
	Bo	Ao	Ko	F	So	W	
3	8.02	5.20	13.60	11.50	--	24.00	320
4	10.51	5.79	15.05	14.20	28.40	32.00	250
5	13.10	5.20	13.60	11.50	---	24.00	320

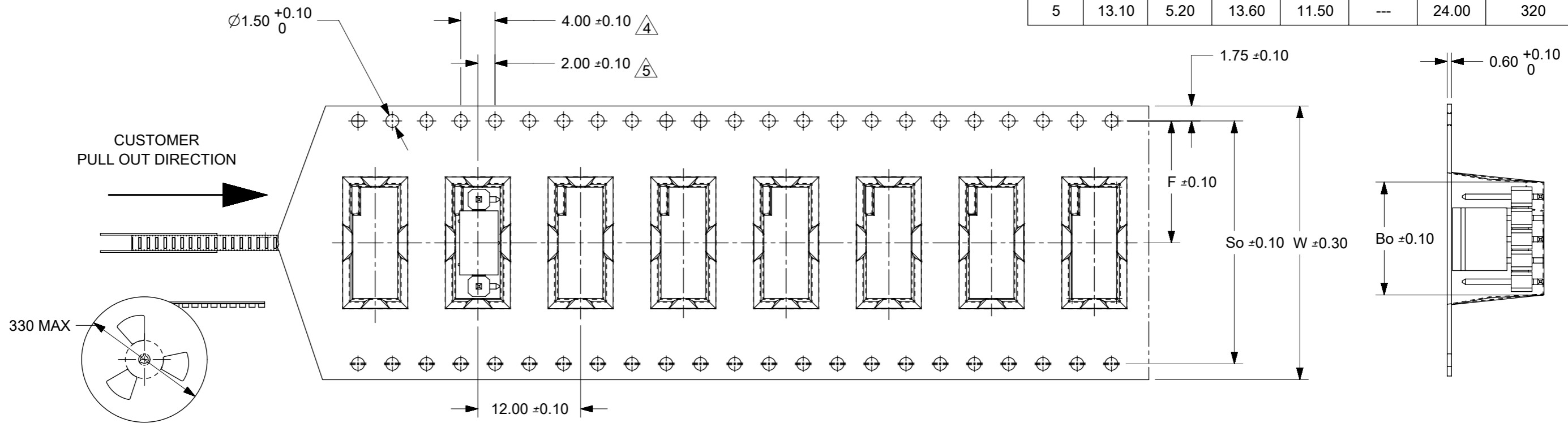

NOTES:

1. LEADER AND TRAILER TAPE

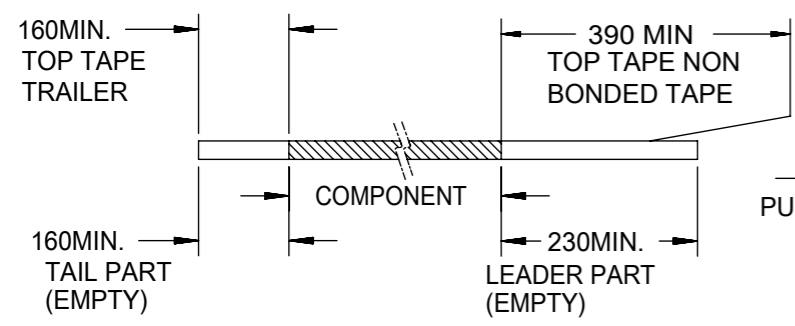

2. PEELING OFF FORCE OF THE TOP TAPE: 20 - 80gf. (PEELING DIRECTION AS SHOWN IN FOLLOWING FIGURE)

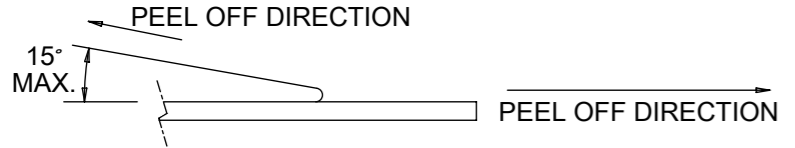

- 3. MATERIAL: BLACK P.S CONDUCTIVE, BLACK
- 4. MEASURED FROM CENTRELINE OF SPROCKET HOLE TO CENTRELINE OF POCKET
- 5. CUMULATIVE TOLERANCE OF 10 SPROCKET HOLE IS ±0.20mm
- 6. A0 AND B0 ARE MEASURE FROM ABOVE POCKET BASE 0.30mm
- 7. TAPE AND REEL SPECIFICATION IS AS PER EIA-481.
- 8. THE TAPE IS TREATED FOR ANTI-STATIC.
- 9. ALL RADIUS ARE 0.30MM UNLESS SPECIFY
- 10. SURFACE RESISTIVITY 10<sup>3</sup> TO 10 OHMS.

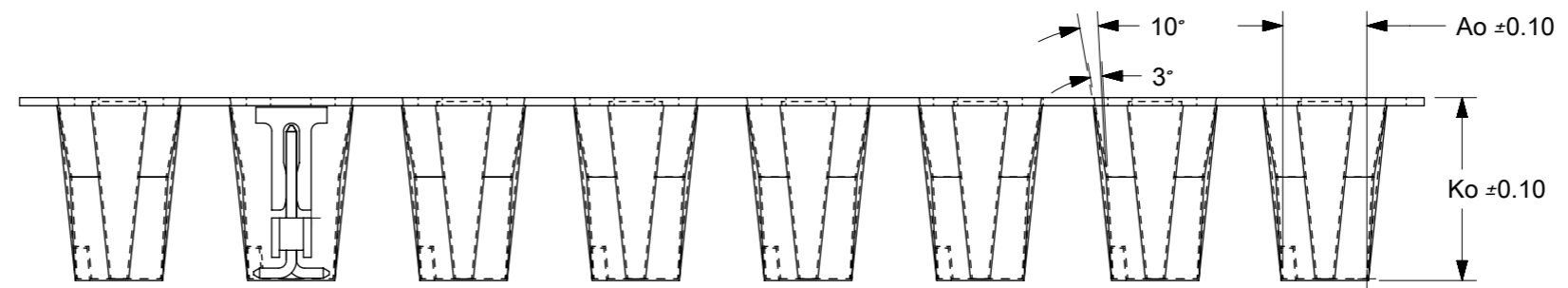

PART PACK IN E/TAPE ORIENTATION (FOR REF USE)

THIS DRAWING CONTAINS INFORMATION THAT IS PROPRIETARY TO MOLEX ELECTRONIC TECHNOLOGIES, LLC AND SHOULD NOT BE USED WITHOUT WRITTEN PERMISSION

DIMENSION UNITS	SCALE	CURRENT REV DESC: SH_04 & 05 UPDATED		<b>molex</b>		
mm	NTS					
GENERAL TOLERANCES (UNLESS SPECIFIED)				CUSTOM HEADER		
				2.54MM PITCH SINGLE ROW SINGLE WAFER SMT HEADER		
				PRODUCT CUSTOMER DRAWING		
4 PLACES ±				EC NO: 177265	DOCUMENT NUMBER	DOC TYPE
3 PLACES ±				DRWN: RLALSANGI 2018/05/16	SD-87898-003	PSD
2 PLACES ± 0.2 ±				CHK'D: MBELLE 2018/05/25	DOC PART	001
1 PLACE ±				APPR: ISHWARG 2018/06/13	REVISION	C
0 PLACES ±				INITIAL REVISION:		
ANGULAR TOL ± 3.0°				DRWN: SKLIM01 2005/10/26		
DRAFT WHERE APPLICABLE MUST REMAIN WITHIN DIMENSIONS				APPR: PTLIM 2005/11/07		
THIRD ANGLE PROJECTION		DRAWING	SERIES	MATERIAL NUMBER	CUSTOMER	SHEET NUMBER
A3-SIZE		87898	SEE TABLE	GENERAL MARKET	3 OF 17	



9 8 7 6 5 4 3 2 1

PACKAGING OPTION PART NO.						CKT SIZE	VOID POSITION	PLATING TYPE	DIMENSION			
TRAY WITHOUT CAP	TRAY WITH CAP	TUBE WITHOUT CAP	TUBE WITH CAP	TAPE & REEL WITHOUT CAP	TAPE & REEL WITH CAP				A	B	F	M
-----	(C) 87898-0361	-----	-----	-----	-----	3	----	1	7.62	5.08	11.94	8.13
-----	(C) 87898-0362	-----	-----	-----	-----	3	----	2	7.62	5.08	11.94	8.13
-----	(C) 87898-0364	-----	-----	-----	87898-0369	3	----	4	7.62	5.08	11.94	8.13
-----	(C) 87898-0365	-----	-----	-----	-----	3	----	5	7.62	5.08	11.94	8.13
-----	(C) 87898-0366	-----	87898-0367	-----	87898-0368	3	----	6	7.62	5.08	11.94	8.13

E

E

D

D

C

C

B

B

A

A

THIS DRAWING CONTAINS INFORMATION THAT IS PROPRIETARY TO MOLEX ELECTRONIC TECHNOLOGIES, LLC AND SHOULD NOT BE USED WITHOUT WRITTEN PERMISSION											
DIMENSION UNITS		SCALE		CURRENT REV DESC: SH_04 & 05 UPDATED						<b>molex</b>	
mm		NTS									
GENERAL TOLERANCES (UNLESS SPECIFIED)				EC NO: 177265		2018/05/16		CUSTOM HEADER 2.54MM PITCH SINGLE ROW SINGLE WAFER SMT HEADER			
4 PLACES		±		DRWN: RLALSANGI		2018/05/25					
3 PLACES		±		CHK'D: MBELLE		2018/06/13		PRODUCT CUSTOMER DRAWING			
2 PLACES		± 0.2		APPR: ISHWARG							
1 PLACE		±		INITIAL REVISION:				DOCUMENT NUMBER		DOC TYPE	
0 PLACES		±		DRWN: SKLIM01		2005/10/26		SD-87898-003		PSD	
ANGULAR TOL		± 3.0°		APPR: PTLIM		2005/11/07		DOC PART		001	
DRAFT WHERE APPLICABLE MUST REMAIN WITHIN DIMENSIONS				THIRD ANGLE PROJECTION		DRAWING		SERIES		SHEET NUMBER	
						A3-SIZE		87898		4 OF 17	
						MATERIAL NUMBER		CUSTOMER			
						SEE TABLE		GENERAL MARKET			

DOCUMENT STATUS	P1	RELEASE DATE	2018/06/13	11:06:55
-----------------	----	--------------	------------	----------

9 8 7 6 5 4 3 2 1

FORMAT: Mef-lega-master-ib-prod-A3  
REVISION: D  
DATE: 2018/01/18

PACKAGING OPTION PART NO.						CKT SIZE	PEG	VOID POSITION	PLATING TYPE	DIMENSION			
TRAY WITHOUT CAP	TRAY WITH CAP	TUBE WITHOUT CAP	TUBE WITH CAP	TAPE & REEL WITHOUT CAP	TAPE & REEL WITH CAP					A	B	F	M
-----	-----	87898-0461	-----	-----	-----	4	---	----	1	10.16	7.62	11.94	8.13
-----	-----	87898-0462	-----	-----	-----	4	---	----	2	10.16	7.62	11.94	8.13
-----	-----	87898-0464	-----	-----	-----	4	---	----	4	10.16	7.62	11.94	8.13
-----	-----	87898-0465	-----	-----	-----	4	---	----	5	10.16	7.62	11.94	8.13
-----	-----	87898-0466	-----	-----	87898-0467	4	---	----	6	10.16	7.62	11.94	8.13
-----	-----	-----	-----	-----	87898-0468	4	Y	----	6	10.16	7.62	11.94	8.13
-----	-----	87898-0561	-----	-----	-----	5	---	----	1	12.70	10.16	11.94	8.13
-----	-----	87898-0562	-----	-----	-----	5	---	----	2	12.70	10.16	11.94	8.13
-----	-----	87898-0564	-----	-----	-----	5	---	----	4	12.70	10.16	11.94	8.13
-----	-----	87898-0565	-----	-----	-----	5	---	----	5	12.70	10.16	11.94	8.13
-----	-----	87898-0566	87898-0567	-----	87898-0568	5	---	----	6	12.70	10.16	11.94	8.13
-----	-----	87898-0661	-----	-----	-----	6	---	----	1	15.24	12.70	11.94	8.13
-----	-----	87898-0662	-----	-----	-----	6	---	----	2	15.24	12.70	11.94	8.13
-----	-----	87898-0664	-----	-----	-----	6	---	----	4	15.24	12.70	11.94	8.13
-----	-----	87898-0665	-----	-----	-----	6	---	----	5	15.24	12.70	11.94	8.13
-----	-----	87898-0666	-----	-----	(C) 87898-0605	6	---	----	6	15.24	12.70	11.94	8.13

4 CKT WITH PEG FOR ILLUSTRATION ONLY

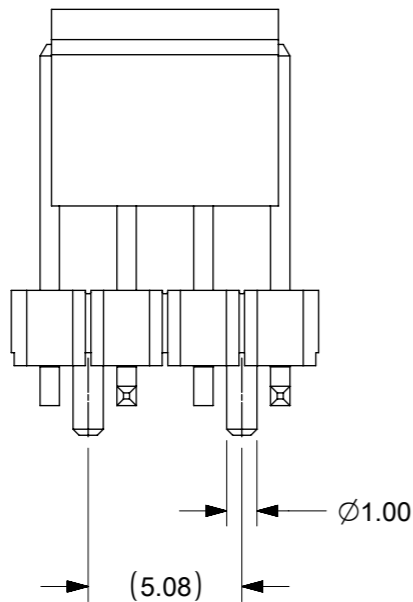

THIS DRAWING CONTAINS INFORMATION THAT IS PROPRIETARY TO MOLEX ELECTRONIC TECHNOLOGIES, LLC AND SHOULD NOT BE USED WITHOUT WRITTEN PERMISSION											
DIMENSION UNITS		SCALE		CURRENT REV DESC: SH_04 & 05 UPDATED							
mm		NTS									
GENERAL TOLERANCES (UNLESS SPECIFIED)				EC NO: 177265		DRWN: RLALSANGI		2018/05/16		CUSTOM HEADER 2.54MM PITCH SINGLE ROW SINGLE WAFER SMT HEADER	
				CHK'D: MBELLE		2018/05/25					
4 PLACES ±				APPR: ISHWARG		2018/06/13		PRODUCT CUSTOMER DRAWING			
3 PLACES ±				INITIAL REVISION:		DRWN: SKLIM01		2005/10/26		DOCUMENT NUMBER	
2 PLACES ± 0.2				APPR: PTLIM		2005/11/07		SD-87898-003		DOC TYPE DOC PART REVISION	
1 PLACE ±				DRAFT WHERE APPLICABLE MUST REMAIN WITHIN DIMENSIONS		THIRD ANGLE PROJECTION		DRAWING		SHEET NUMBER	
0 PLACES ±								A3-SIZE		5 OF 17	
ANGULAR TOL ± 3.0°								SERIES		CUSTOMER	
								87898		GENERAL MARKET	

PACKAGING OPTION PART NO.						CKT SIZE	VOID POSITION	PLATING TYPE	DIMENSION			
TRAY WITHOUT CAP	TRAY WITH CAP	TUBE WITHOUT CAP	TUBE WITH CAP	TAPE & REEL WITHOUT CAP	TAPE & REEL WITH CAP				A	B	F	M
-----	-----	87898-0761	-----	-----	-----	7	----	1	17.78	15.24	11.94	8.13
-----	-----	87898-0762	-----	-----	-----	7	----	2	17.78	15.24	11.94	8.13
-----	-----	87898-0764	-----	-----	-----	7	----	4	17.78	15.24	11.94	8.13
-----	-----	87898-0765	-----	-----	-----	7	----	5	17.78	15.24	11.94	8.13
-----	-----	87898-0766	-----	-----	-----	7	----	6	17.78	15.24	11.94	8.13
-----	-----	87898-0861	-----	-----	-----	8	----	1	20.32	17.78	11.94	8.13
-----	-----	87898-0862	-----	-----	-----	8	----	2	20.32	17.78	11.94	8.13
-----	-----	87898-0864	-----	-----	-----	8	----	4	20.32	17.78	11.94	8.13
-----	-----	87898-0865	-----	-----	-----	8	----	5	20.32	17.78	11.94	8.13
-----	-----	87898-0866	-----	-----	-----	8	----	6	20.32	17.78	11.94	8.13
-----	-----	87898-0961	-----	-----	-----	9	----	1	22.86	20.32	11.94	8.13
-----	-----	87898-0962	-----	-----	-----	9	----	2	22.86	20.32	11.94	8.13
-----	-----	87898-0964	-----	-----	-----	9	----	4	22.86	20.32	11.94	8.13
-----	-----	87898-0965	-----	-----	-----	9	----	5	22.86	20.32	11.94	8.13
-----	-----	87898-0966	-----	-----	-----	9	----	6	22.86	20.32	11.94	8.13

THIS DRAWING CONTAINS INFORMATION THAT IS PROPRIETARY TO MOLEX ELECTRONIC TECHNOLOGIES, LLC AND SHOULD NOT BE USED WITHOUT WRITTEN PERMISSION											
DIMENSION UNITS		SCALE		CURRENT REV DESC: SH_04 & 05 UPDATED						<b>molex</b>	
mm		NTS		EC NO: 177265							
GENERAL TOLERANCES (UNLESS SPECIFIED)				DRWN: RLALSANGI		2018/05/16		CUSTOM HEADER			
		MM		INCH		CHK'D: MBELLE		2018/05/25		2.54MM PITCH SINGLE ROW SINGLE WAFER SMT HEADER	
4 PLACES		±		±		APPR: ISHWARG		2018/06/13		PRODUCT CUSTOMER DRAWING	
3 PLACES		±		±		INITIAL REVISION:		DOCUMENT NUMBER		DOC TYPE	
2 PLACES		±		0.2		DRWN: SKLIM01		2005/10/26		DOC PART	
1 PLACE		±		±		APPR: PTLIM		2005/11/07		REVISION	
0 PLACES		±		±		ANGULAR TOL		± 3.0°		SD-87898-003	
DRAFT WHERE APPLICABLE MUST REMAIN WITHIN DIMENSIONS				THIRD ANGLE PROJECTION		DRAWING		SERIES		MATERIAL NUMBER	
						A3-SIZE		87898		SEE TABLE	
						GENERAL MARKET				SHEET NUMBER	
										6 OF 17	

PACKAGING OPTION PART NO.						CKT SIZE	VOID POSITION	PLATING TYPE	DIMENSION			
TRAY WITHOUT CAP	TRAY WITH CAP	TUBE WITHOUT CAP	TUBE WITH CAP	TAPE & REEL WITHOUT CAP	TAPE & REEL WITH CAP				A	B	F	M
-----	-----	87898-1061	-----	-----	-----	10	----	1	25.40	22.86	11.94	8.13
-----	-----	87898-1062	-----	-----	-----	10	----	2	25.40	22.86	11.94	8.13
-----	-----	87898-1064	-----	-----	-----	10	----	4	25.40	22.86	11.94	8.13
-----	-----	87898-1065	-----	-----	-----	10	----	5	25.40	22.86	11.94	8.13
-----	-----	87898-1066	-----	-----	-----	10	----	6	25.40	22.86	11.94	8.13
-----	-----	87898-1161	-----	-----	-----	11	----	1	27.94	25.40	11.94	8.13
-----	-----	87898-1162	-----	-----	-----	11	----	2	27.94	25.40	11.94	8.13
-----	-----	87898-1164	-----	-----	-----	11	----	4	27.94	25.40	11.94	8.13
-----	-----	87898-1165	-----	-----	-----	11	----	5	27.94	25.40	11.94	8.13
-----	-----	87898-1166	-----	-----	-----	11	----	6	27.94	25.40	11.94	8.13
-----	-----	87898-1261	-----	-----	-----	12	----	1	30.48	27.94	11.94	8.13
-----	-----	87898-1262	-----	-----	-----	12	----	2	30.48	27.94	11.94	8.13
-----	-----	87898-1264	-----	-----	-----	12	----	4	30.48	27.94	11.94	8.13
-----	-----	87898-1265	-----	-----	-----	12	----	5	30.48	27.94	11.94	8.13
-----	-----	87898-1266	-----	-----	-----	12	----	6	30.48	27.94	11.94	8.13

THIS DRAWING CONTAINS INFORMATION THAT IS PROPRIETARY TO MOLEX ELECTRONIC TECHNOLOGIES, LLC AND SHOULD NOT BE USED WITHOUT WRITTEN PERMISSION											
DIMENSION UNITS		SCALE		CURRENT REV DESC: SH_04 & 05 UPDATED							
mm		NTS		EC NO: 177265							
GENERAL TOLERANCES (UNLESS SPECIFIED)				DRWN: RLALSANGI		2018/05/16		CUSTOM HEADER 2.54MM PITCH SINGLE ROW SINGLE WAFER SMT HEADER			
				CHK'D: MBELLE		2018/05/25					
				APPR: ISHWARG		2018/06/13		PRODUCT CUSTOMER DRAWING			
				INITIAL REVISION:				DOCUMENT NUMBER		DOC TYPE	
				DRWN: SKLIM01		2005/10/26		SD-87898-003		PSD	
				APPR: PTLIM		2005/11/07		001		C	
ANGULAR TOL ± 3.0°				DRAFT WHERE APPLICABLE MUST REMAIN WITHIN DIMENSIONS		THIRD ANGLE PROJECTION		DRAWING		SHEET NUMBER	
						A3-SIZE		SERIES		7 OF 17	
						87898		MATERIAL NUMBER		GENERAL MARKET	
						SEE TABLE		CUSTOMER			

PACKAGING OPTION PART NO.						CKT SIZE	VOID POSITION	PLATING TYPE	DIMENSION			
TRAY WITHOUT CAP	TRAY WITH CAP	TUBE WITHOUT CAP	TUBE WITH CAP	TAPE & REEL WITHOUT CAP	TAPE & REEL WITH CAP				A	B	F	M
-----	-----	87898-1361	-----	-----	-----	13	----	1	33.02	30.48	11.94	8.13
-----	-----	87898-1362	-----	-----	-----	13	----	2	33.02	30.48	11.94	8.13
-----	-----	87898-1364	-----	-----	-----	13	----	4	33.02	30.48	11.94	8.13
-----	-----	87898-1365	-----	-----	-----	13	----	5	33.02	30.48	11.94	8.13
-----	-----	87898-1366	-----	-----	-----	13	----	6	33.02	30.48	11.94	8.13
-----	-----	87898-1461	-----	-----	-----	14	----	1	35.56	33.02	11.94	8.13
-----	-----	87898-1462	-----	-----	-----	14	----	2	35.56	33.02	11.94	8.13
-----	-----	87898-1464	-----	-----	-----	14	----	4	35.56	33.02	11.94	8.13
-----	-----	87898-1465	-----	-----	-----	14	----	5	35.56	33.02	11.94	8.13
-----	-----	87898-1466	-----	-----	-----	14	----	6	35.56	33.02	11.94	8.13
-----	-----	87898-1561	-----	-----	-----	15	----	1	38.10	35.56	11.94	8.13
-----	-----	87898-1562	-----	-----	-----	15	----	2	38.10	35.56	11.94	8.13
-----	-----	87898-1564	-----	-----	-----	15	----	4	38.10	35.56	11.94	8.13
-----	-----	87898-1565	-----	-----	-----	15	----	5	38.10	35.56	11.94	8.13
-----	-----	87898-1566	-----	-----	-----	15	----	6	38.10	35.56	11.94	8.13

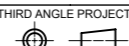
THIS DRAWING CONTAINS INFORMATION THAT IS PROPRIETARY TO MOLEX ELECTRONIC TECHNOLOGIES, LLC AND SHOULD NOT BE USED WITHOUT WRITTEN PERMISSION											
DIMENSION UNITS		SCALE		CURRENT REV DESC: SH_04 & 05 UPDATED				 CUSTOM HEADER 2.54MM PITCH SINGLE ROW SINGLE WAFER SMT HEADER			
mm		NTS		EC NO: 177265							
GENERAL TOLERANCES (UNLESS SPECIFIED)				DRWN: RLALSANGI 2018/05/16				PRODUCT CUSTOMER DRAWING			
				CHK'D: MBELLE 2018/05/25							
				APPR: ISHWARG 2018/06/13				DOCUMENT NUMBER: SD-87898-003 DOC TYPE: PSD DOC PART: 001 REVISION: C			
				INITIAL REVISION:							
4 PLACES ±				DRWN: SKLIM01 2005/10/26				MATERIAL NUMBER: SEE TABLE CUSTOMER: GENERAL MARKET SHEET NUMBER: 8 OF 17			
3 PLACES ±				APPR: PTLIM 2005/11/07							
2 PLACES ± 0.2				DRAFT WHERE APPLICABLE MUST REMAIN WITHIN DIMENSIONS				THIRD ANGLE PROJECTION  DRAWING: A3-SIZE SERIES: 87898			
1 PLACE ±											
0 PLACES ±											
ANGULAR TOL ± 3.0°											

PACKAGING OPTION PART NO.						CKT SIZE	VOID POSITION	PLATING TYPE	DIMENSION			
TRAY WITHOUT CAP	TRAY WITH CAP	TUBE WITHOUT CAP	TUBE WITH CAP	TAPE & REEL WITHOUT CAP	TAPE & REEL WITH CAP				A	B	F	M
-----	-----	87898-1661	-----	-----	-----	16	----	1	40.64	38.10	11.94	8.13
-----	-----	87898-1662	-----	-----	-----	16	----	2	40.64	38.10	11.94	8.13
-----	-----	87898-1664	-----	-----	-----	16	----	4	40.64	38.10	11.94	8.13
-----	-----	87898-1665	-----	-----	-----	16	----	5	40.64	38.10	11.94	8.13
-----	-----	87898-1666	-----	-----	-----	16	----	6	40.64	38.10	11.94	8.13
-----	-----	87898-1761	-----	-----	-----	17	----	1	43.18	40.64	11.94	8.13
-----	-----	87898-1762	-----	-----	-----	17	----	2	43.18	40.64	11.94	8.13
-----	-----	87898-1764	-----	-----	-----	17	----	4	43.18	40.64	11.94	8.13
-----	-----	87898-1765	-----	-----	-----	17	----	5	43.18	40.64	11.94	8.13
-----	-----	87898-1766	-----	-----	-----	17	----	6	43.18	40.64	11.94	8.13
-----	-----	87898-1861	-----	-----	-----	18	----	1	45.72	43.18	11.94	8.13
-----	-----	87898-1862	-----	-----	-----	18	----	2	45.72	43.18	11.94	8.13
-----	-----	87898-1864	-----	-----	-----	18	----	4	45.72	43.18	11.94	8.13
-----	-----	87898-1865	-----	-----	-----	18	----	5	45.72	43.18	11.94	8.13
-----	-----	87898-1866	-----	-----	-----	18	----	6	45.72	43.18	11.94	8.13

THIS DRAWING CONTAINS INFORMATION THAT IS PROPRIETARY TO MOLEX ELECTRONIC TECHNOLOGIES, LLC AND SHOULD NOT BE USED WITHOUT WRITTEN PERMISSION											
DIMENSION UNITS		SCALE		CURRENT REV DESC: SH_04 & 05 UPDATED							
mm		NTS		EC NO: 177265							
GENERAL TOLERANCES (UNLESS SPECIFIED)				DRWN: RLALSANGI		2018/05/16		CUSTOM HEADER 2.54MM PITCH SINGLE ROW SINGLE WAFER SMT HEADER			
				CHK'D: MBELLE		2018/05/25					
				APPR: ISHWARG		2018/06/13		PRODUCT CUSTOMER DRAWING			
				INITIAL REVISION:				DOCUMENT NUMBER		DOC TYPE   DOC PART   REVISION	
				DRWN: SKLIM01		2005/10/26		SD-87898-003		PSD   001   C	
				APPR: PTLIM		2005/11/07		MATERIAL NUMBER		CUSTOMER	
ANGULAR TOL ± 3.0°				DRAWING		SERIES		SEE TABLE		GENERAL MARKET	
DRAFT WHERE APPLICABLE MUST REMAIN WITHIN DIMENSIONS				THIRD ANGLE PROJECTION		A3-SIZE		87898		SHEET NUMBER	
				9 OF 17							

PACKAGING OPTION PART NO.						CKT SIZE	VOID POSITION	PLATING TYPE	DIMENSION			
TRAY WITHOUT CAP	TRAY WITH CAP	TUBE WITHOUT CAP	TUBE WITH CAP	TAPE & REEL WITHOUT CAP	TAPE & REEL WITH CAP				A	B	F	M
-----	-----	87898-1961	-----	-----	-----	19	----	1	48.26	45.72	11.94	8.13
-----	-----	87898-1962	-----	-----	-----	19	----	2	48.26	45.72	11.94	8.13
-----	-----	87898-1964	-----	-----	-----	19	----	4	48.26	45.72	11.94	8.13
-----	-----	87898-1965	-----	-----	-----	19	----	5	48.26	45.72	11.94	8.13
-----	-----	87898-1966	-----	-----	-----	19	----	6	48.26	45.72	11.94	8.13
-----	-----	87898-2061	-----	-----	-----	20	----	1	50.80	48.26	11.94	8.13
-----	-----	87898-2062	-----	-----	-----	20	----	2	50.80	48.26	11.94	8.13
-----	-----	87898-2064	-----	-----	-----	20	----	4	50.80	48.26	11.94	8.13
-----	-----	87898-2065	-----	-----	-----	20	----	5	50.80	48.26	11.94	8.13
-----	-----	87898-2066	-----	-----	-----	20	----	6	50.80	48.26	11.94	8.13
-----	-----	87898-2161	-----	-----	-----	21	----	1	53.34	50.80	11.94	8.13
-----	-----	87898-2162	-----	-----	-----	21	----	2	53.34	50.80	11.94	8.13
-----	-----	87898-2164	-----	-----	-----	21	----	4	53.34	50.80	11.94	8.13
-----	-----	87898-2165	-----	-----	-----	21	----	5	53.34	50.80	11.94	8.13
-----	-----	87898-2166	-----	-----	-----	21	----	6	53.34	50.80	11.94	8.13

THIS DRAWING CONTAINS INFORMATION THAT IS PROPRIETARY TO MOLEX ELECTRONIC TECHNOLOGIES, LLC AND SHOULD NOT BE USED WITHOUT WRITTEN PERMISSION											
DIMENSION UNITS		SCALE		CURRENT REV DESC: SH_04 & 05 UPDATED						<b>molex</b>	
mm		NTS		EC NO: 177265							
GENERAL TOLERANCES (UNLESS SPECIFIED)				DRWN: RLALSANGI		2018/05/16		CUSTOM HEADER			
				CHK'D: MBELLE		2018/05/25		2.54MM PITCH SINGLE ROW SINGLE WAFER SMT HEADER			
				APPR: ISHWARG		2018/06/13		PRODUCT CUSTOMER DRAWING			
4 PLACES ±				INITIAL REVISION:		DRWN: SKLIM01		DOCUMENT NUMBER		DOC TYPE	
3 PLACES ±				2005/10/26		2005/11/07		SD-87898-003		PSD	
2 PLACES ± 0.2				APPR: PTLIM		2005/11/07		001		C	
1 PLACE ±				DRAFT WHERE APPLICABLE MUST REMAIN WITHIN DIMENSIONS		THIRD ANGLE PROJECTION		DRAWING		SERIES	
0 PLACES ±						A3-SIZE		87898		MATERIAL NUMBER	
ANGULAR TOL ± 3.0°						SEE TABLE		CUSTOMER		SHEET NUMBER	
						GENERAL MARKET		10 OF 17			

PACKAGING OPTION PART NO.						CKT SIZE	VOID POSITION	PLATING TYPE	DIMENSION			
TRAY WITHOUT CAP	TRAY WITH CAP	TUBE WITHOUT CAP	TUBE WITH CAP	TAPE & REEL WITHOUT CAP	TAPE & REEL WITH CAP				A	B	F	M
-----	-----	87898-2261	-----	-----	-----	22	----	1	55.88	53.34	11.94	8.13
-----	-----	87898-2262	-----	-----	-----	22	----	2	55.88	53.34	11.94	8.13
-----	-----	87898-2264	-----	-----	-----	22	----	4	55.88	53.34	11.94	8.13
-----	-----	87898-2265	-----	-----	-----	22	----	5	55.88	53.34	11.94	8.13
-----	-----	87898-2266	-----	-----	-----	22	----	6	55.88	53.34	11.94	8.13
-----	-----	87898-2361	-----	-----	-----	23	----	1	58.42	55.88	11.94	8.13
-----	-----	87898-2362	-----	-----	-----	23	----	2	58.42	55.88	11.94	8.13
-----	-----	87898-2364	-----	-----	-----	23	----	4	58.42	55.88	11.94	8.13
-----	-----	87898-2365	-----	-----	-----	23	----	5	58.42	55.88	11.94	8.13
-----	-----	87898-2366	-----	-----	-----	23	----	6	58.42	55.88	11.94	8.13
-----	-----	87898-2461	-----	-----	-----	24	----	1	60.96	58.42	11.94	8.13
-----	-----	87898-2462	-----	-----	-----	24	----	2	60.96	58.42	11.94	8.13
-----	-----	87898-2464	-----	-----	-----	24	----	4	60.96	58.42	11.94	8.13
-----	-----	87898-2465	-----	-----	-----	24	----	5	60.96	58.42	11.94	8.13
-----	-----	87898-2466	-----	-----	-----	24	----	6	60.96	58.42	11.94	8.13

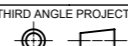
THIS DRAWING CONTAINS INFORMATION THAT IS PROPRIETARY TO MOLEX ELECTRONIC TECHNOLOGIES, LLC AND SHOULD NOT BE USED WITHOUT WRITTEN PERMISSION													
DIMENSION UNITS		SCALE		CURRENT REV DESC: SH_04 & 05 UPDATED									
mm		NTS		EC NO: 177265									
GENERAL TOLERANCES (UNLESS SPECIFIED)				DRWN: RLALSANGI 2018/05/16				CUSTOM HEADER 2.54MM PITCH SINGLE ROW SINGLE WAFER SMT HEADER					
				CHK'D: MBELLE 2018/05/25									
				APPR: ISHWARG 2018/06/13				PRODUCT CUSTOMER DRAWING					
4 PLACES ±				INITIAL REVISION:				DOCUMENT NUMBER		DOC TYPE		DOC PART	
3 PLACES ±				DRWN: SKLIM01 2005/10/26				SD-87898-003		PSD		001	
2 PLACES ± 0.2				APPR: PTLIM 2005/11/07								C	
1 PLACE ±				DRAFT WHERE APPLICABLE MUST REMAIN WITHIN DIMENSIONS				THIRD ANGLE PROJECTION		DRAWING		SERIES	
0 PLACES ±								A3-SIZE		87898		MATERIAL NUMBER	
ANGULAR TOL ± 3.0°				SEE TABLE				GENERAL MARKET		CUSTOMER		SHEET NUMBER	
												11 OF 17	

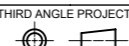

PACKAGING OPTION PART NO.						CKT SIZE	VOID POSITION	PLATING TYPE	DIMENSION			
TRAY WITHOUT CAP	TRAY WITH CAP	TUBE WITHOUT CAP	TUBE WITH CAP	TAPE & REEL WITHOUT CAP	TAPE & REEL WITH CAP				A	B	F	M
-----	-----	87898-2561	-----	-----	-----	25	----	1	63.50	60.96	11.94	8.13
-----	-----	87898-2562	-----	-----	-----	25	----	2	63.50	60.96	11.94	8.13
-----	-----	87898-2564	-----	-----	-----	25	----	4	63.50	60.96	11.94	8.13
-----	-----	87898-2565	-----	-----	-----	25	----	5	63.50	60.96	11.94	8.13
-----	-----	87898-2566	-----	-----	-----	25	----	6	63.50	60.96	11.94	8.13
-----	-----	87898-2661	-----	-----	-----	26	----	1	66.04	63.50	11.94	8.13
-----	-----	87898-2662	-----	-----	-----	26	----	2	66.04	63.50	11.94	8.13
-----	-----	87898-2664	-----	-----	-----	26	----	4	66.04	63.50	11.94	8.13
-----	-----	87898-2665	-----	-----	-----	26	----	5	66.04	63.50	11.94	8.13
-----	-----	87898-2666	-----	-----	-----	26	----	6	66.04	63.50	11.94	8.13
-----	-----	87898-2761	-----	-----	-----	27	----	1	68.58	66.04	11.94	8.13
-----	-----	87898-2762	-----	-----	-----	27	----	2	68.58	66.04	11.94	8.13
-----	-----	87898-2764	-----	-----	-----	27	----	4	68.58	66.04	11.94	8.13
-----	-----	87898-2765	-----	-----	-----	27	----	5	68.58	66.04	11.94	8.13
-----	-----	87898-2766	-----	-----	-----	27	----	6	68.58	66.04	11.94	8.13

THIS DRAWING CONTAINS INFORMATION THAT IS PROPRIETARY TO MOLEX ELECTRONIC TECHNOLOGIES, LLC AND SHOULD NOT BE USED WITHOUT WRITTEN PERMISSION													
DIMENSION UNITS		SCALE		CURRENT REV DESC: SH_04 & 05 UPDATED									
mm		NTS		EC NO: 177265									
GENERAL TOLERANCES (UNLESS SPECIFIED)				DRWN: RLALSANGI 2018/05/16				CUSTOM HEADER 2.54MM PITCH SINGLE ROW SINGLE WAFER SMT HEADER					
				CHK'D: MBELLE 2018/05/25									
				APPR: ISHWARG 2018/06/13				PRODUCT CUSTOMER DRAWING					
				INITIAL REVISION:									
4 PLACES ±				DRWN: SKLIM01 2005/10/26				DOCUMENT NUMBER		DOC TYPE		DOC PART	
3 PLACES ±				APPR: PTLIM 2005/11/07				SD-87898-003		PSD		001	
2 PLACES ± 0.2													
1 PLACE ±													
0 PLACES ±													
ANGULAR TOL ± 3.0°													
DRAFT WHERE APPLICABLE MUST REMAIN WITHIN DIMENSIONS				THIRD ANGLE PROJECTION		DRAWING		SERIES		MATERIAL NUMBER		CUSTOMER	
						A3-SIZE		87898		SEE TABLE		GENERAL MARKET	
												SHEET NUMBER	
												12 OF 17	

PACKAGING OPTION PART NO.						CKT SIZE	VOID POSITION	PLATING TYPE	DIMENSION			
TRAY WITHOUT CAP	TRAY WITH CAP	TUBE WITHOUT CAP	TUBE WITH CAP	TAPE & REEL WITHOUT CAP	TAPE & REEL WITH CAP				A	B	F	M
-----	-----	87898-2861	-----	-----	-----	28	----	1	71.12	68.58	11.94	8.13
-----	-----	87898-2862	-----	-----	-----	28	----	2	71.12	68.58	11.94	8.13
-----	-----	87898-2864	-----	-----	-----	28	----	4	71.12	68.58	11.94	8.13
-----	-----	87898-2865	-----	-----	-----	28	----	5	71.12	68.58	11.94	8.13
-----	-----	87898-2866	-----	-----	-----	28	----	6	71.12	68.58	11.94	8.13
-----	-----	87898-2961	-----	-----	-----	29	----	1	73.66	71.12	11.94	8.13
-----	-----	87898-2962	-----	-----	-----	29	----	2	73.66	71.12	11.94	8.13
-----	-----	87898-2964	-----	-----	-----	29	----	4	73.66	71.12	11.94	8.13
-----	-----	87898-2965	-----	-----	-----	29	----	5	73.66	71.12	11.94	8.13
-----	-----	87898-2966	-----	-----	-----	29	----	6	73.66	71.12	11.94	8.13
-----	-----	87898-3061	-----	-----	-----	30	----	1	76.20	73.66	11.94	8.13
-----	-----	87898-3062	-----	-----	-----	30	----	2	76.20	73.66	11.94	8.13
-----	-----	87898-3064	-----	-----	-----	30	----	4	76.20	73.66	11.94	8.13
-----	-----	87898-3065	-----	-----	-----	30	----	5	76.20	73.66	11.94	8.13
-----	-----	87898-3066	-----	-----	-----	30	----	6	76.20	73.66	11.94	8.13

THIS DRAWING CONTAINS INFORMATION THAT IS PROPRIETARY TO MOLEX ELECTRONIC TECHNOLOGIES, LLC AND SHOULD NOT BE USED WITHOUT WRITTEN PERMISSION											
DIMENSION UNITS		SCALE		CURRENT REV DESC: SH_04 & 05 UPDATED						<b>molex</b>	
mm		NTS		EC NO: 177265							
GENERAL TOLERANCES (UNLESS SPECIFIED)				DRWN: RLALSANGI		2018/05/16		CUSTOM HEADER			
				CHK'D: MBELLE		2018/05/25		2.54MM PITCH SINGLE ROW SINGLE WAFER SMT HEADER			
				APPR: ISHWARG		2018/06/13		PRODUCT CUSTOMER DRAWING			
4 PLACES ±				INITIAL REVISION:		DRWN: SKLIM01		DOCUMENT NUMBER		DOC TYPE	
3 PLACES ±				DRWN: SKLIM01		2005/10/26		SD-87898-003		PSD	
2 PLACES ± 0.2				APPR: PTLIM		2005/11/07		001		C	
1 PLACE ±				DRAFT WHERE APPLICABLE MUST REMAIN WITHIN DIMENSIONS		THIRD ANGLE PROJECTION		DRAWING		SERIES	
0 PLACES ±						A3-SIZE		87898		MATERIAL NUMBER	
ANGULAR TOL ± 3.0°						SEE TABLE		CUSTOMER		SHEET NUMBER	
						GENERAL MARKET				13 OF 17	

PACKAGING OPTION PART NO.						CKT SIZE	VOID POSITION	PLATING TYPE	DIMENSION			
TRAY WITHOUT CAP	TRAY WITH CAP	TUBE WITHOUT CAP	TUBE WITH CAP	TAPE & REEL WITHOUT CAP	TAPE & REEL WITH CAP				A	B	F	M
-----	-----	87898-3161	-----	-----	-----	31	----	1	78.74	76.20	11.94	8.13
-----	-----	87898-3162	-----	-----	-----	31	----	2	78.74	76.20	11.94	8.13
-----	-----	87898-3164	-----	-----	-----	31	----	4	78.74	76.20	11.94	8.13
-----	-----	87898-3165	-----	-----	-----	31	----	5	78.74	76.20	11.94	8.13
-----	-----	87898-3166	-----	-----	-----	31	----	6	78.74	76.20	11.94	8.13
-----	-----	87898-3261	-----	-----	-----	32	----	1	81.28	78.74	11.94	8.13
-----	-----	87898-3262	-----	-----	-----	32	----	2	81.28	78.74	11.94	8.13
-----	-----	87898-3264	-----	-----	-----	32	----	4	81.28	78.74	11.94	8.13
-----	-----	87898-3265	-----	-----	-----	32	----	5	81.28	78.74	11.94	8.13
-----	-----	87898-3266	-----	-----	-----	32	----	6	81.28	78.74	11.94	8.13
-----	-----	87898-3361	-----	-----	-----	33	----	1	83.82	81.28	11.94	8.13
-----	-----	87898-3362	-----	-----	-----	33	----	2	83.82	81.28	11.94	8.13
-----	-----	87898-3364	-----	-----	-----	33	----	4	83.82	81.28	11.94	8.13
-----	-----	87898-3365	-----	-----	-----	33	----	5	83.82	81.28	11.94	8.13
-----	-----	87898-3366	-----	-----	-----	33	----	6	83.82	81.28	11.94	8.13

THIS DRAWING CONTAINS INFORMATION THAT IS PROPRIETARY TO MOLEX ELECTRONIC TECHNOLOGIES, LLC AND SHOULD NOT BE USED WITHOUT WRITTEN PERMISSION

DIMENSION UNITS		SCALE		CURRENT REV DESC: SH_04 & 05 UPDATED			<b>molex</b>		
mm		NTS		EC NO: 177265			CUSTOM HEADER		
GENERAL TOLERANCES (UNLESS SPECIFIED)				DRWN: RLALSANGI 2018/05/16			2.54MM PITCH SINGLE ROW SINGLE WAFER SMT HEADER		
				CHK'D: MBELLE 2018/05/25					
4 PLACES ±		±		APPR: ISHWARG 2018/06/13			PRODUCT CUSTOMER DRAWING		
3 PLACES ±		±		INITIAL REVISION:			DOCUMENT NUMBER		
2 PLACES ±		0.2 ±		DRWN: SKLIM01 2005/10/26			SD-87898-003		
1 PLACE ±		±		APPR: PTLIM 2005/11/07			DOC TYPE DOC PART REVISION		
0 PLACES ±		±		ANGULAR TOL ± 3.0°			PSD 001 C		
DRAFT WHERE APPLICABLE MUST REMAIN WITHIN DIMENSIONS				THIRD ANGLE PROJECTION		DRAWING		SERIES	
						A3-SIZE		87898	
						MATERIAL NUMBER		CUSTOMER	
						SEE TABLE		GENERAL MARKET	
								SHEET NUMBER	
								14 OF 17	

PACKAGING OPTION PART NO.						CKT SIZE	VOID POSITION	PLATING TYPE	DIMENSION			
TRAY WITHOUT CAP	TRAY WITH CAP	TUBE WITHOUT CAP	TUBE WITH CAP	TAPE & REEL WITHOUT CAP	TAPE & REEL WITH CAP				A	B	F	M
-----	-----	87898-3461	-----	-----	-----	34	----	1	86.36	83.82	11.94	8.13
-----	-----	87898-3462	-----	-----	-----	34	----	2	86.36	83.82	11.94	8.13
-----	-----	87898-3464	-----	-----	-----	34	----	4	86.36	83.82	11.94	8.13
-----	-----	87898-3465	-----	-----	-----	34	----	5	86.36	83.82	11.94	8.13
-----	-----	87898-3466	-----	-----	-----	34	----	6	86.36	83.82	11.94	8.13
-----	-----	87898-3561	-----	-----	-----	35	----	1	88.90	86.36	11.94	8.13
-----	-----	87898-3562	-----	-----	-----	35	----	2	88.90	86.36	11.94	8.13
-----	-----	87898-3564	-----	-----	-----	35	----	4	88.90	86.36	11.94	8.13
-----	-----	87898-3565	-----	-----	-----	35	----	5	88.90	86.36	11.94	8.13
-----	-----	87898-3566	-----	-----	-----	35	----	6	88.90	86.36	11.94	8.13
-----	-----	87898-3661	-----	-----	-----	36	----	1	91.44	88.90	11.94	8.13
-----	-----	87898-3662	-----	-----	-----	36	----	2	91.44	88.90	11.94	8.13
-----	-----	87898-3664	-----	-----	-----	36	----	4	91.44	88.90	11.94	8.13
-----	-----	87898-3665	-----	-----	-----	36	----	5	91.44	88.90	11.94	8.13
-----	-----	87898-3666	-----	-----	-----	36	----	6	91.44	88.90	11.94	8.13

THIS DRAWING CONTAINS INFORMATION THAT IS PROPRIETARY TO MOLEX ELECTRONIC TECHNOLOGIES, LLC AND SHOULD NOT BE USED WITHOUT WRITTEN PERMISSION											
DIMENSION UNITS		SCALE		CURRENT REV DESC: SH_04 & 05 UPDATED				 CUSTOM HEADER 2.54MM PITCH SINGLE ROW SINGLE WAFER SMT HEADER			
mm		NTS		EC NO: 177265							
GENERAL TOLERANCES (UNLESS SPECIFIED)				DRWN: RLALSANGI 2018/05/16				PRODUCT CUSTOMER DRAWING DOCUMENT NUMBER: SD-87898-003   DOC TYPE: PSD   DOC PART: 001   REVISION: C			
				CHK'D: MBELLE 2018/05/25							
				APPR: ISHWARG 2018/06/13							
4 PLACES ±				INITIAL REVISION:							
3 PLACES ±				DRWN: SKLIM01 2005/10/26							
2 PLACES ± 0.2				APPR: PTLIM 2005/11/07							
1 PLACE ±				DRAFT WHERE APPLICABLE MUST REMAIN WITHIN DIMENSIONS							
0 PLACES ±				THIRD ANGLE PROJECTION							
ANGULAR TOL ± 3.0°				DRAWING							
				SERIES							
				MATERIAL NUMBER							
				CUSTOMER							
				SHEET NUMBER							

PACKAGING OPTION PART NO.						CKT SIZE	VOID POSITION	PLATING TYPE	DIMENSION			
TRAY WITHOUT CAP	TRAY WITH CAP	TUBE WITHOUT CAP	TUBE WITH CAP	TAPE & REEL WITHOUT CAP	TAPE & REEL WITH CAP				A	B	F	M
-----	-----	87898-3761	-----	-----	-----	37	----	1	93.98	91.44	11.94	8.13
-----	-----	87898-3762	-----	-----	-----	37	----	2	93.98	91.44	11.94	8.13
-----	-----	87898-3764	-----	-----	-----	37	----	4	93.98	91.44	11.94	8.13
-----	-----	87898-3765	-----	-----	-----	37	----	5	93.98	91.44	11.94	8.13
-----	-----	87898-3766	-----	-----	-----	37	----	6	93.98	91.44	11.94	8.13
-----	-----	87898-3861	-----	-----	-----	38	----	1	96.52	93.98	11.94	8.13
-----	-----	87898-3862	-----	-----	-----	38	----	2	96.52	93.98	11.94	8.13
-----	-----	87898-3864	-----	-----	-----	38	----	4	96.52	93.98	11.94	8.13
-----	-----	87898-3865	-----	-----	-----	38	----	5	96.52	93.98	11.94	8.13
-----	-----	87898-3866	-----	-----	-----	38	----	6	96.52	93.98	11.94	8.13
-----	-----	87898-3961	-----	-----	-----	39	----	1	99.06	96.52	11.94	8.13
-----	-----	87898-3962	-----	-----	-----	39	----	2	99.06	96.52	11.94	8.13
-----	-----	87898-3964	-----	-----	-----	39	----	4	99.06	96.52	11.94	8.13
-----	-----	87898-3965	-----	-----	-----	39	----	5	99.06	96.52	11.94	8.13
-----	-----	87898-3966	-----	-----	-----	39	----	6	99.06	96.52	11.94	8.13

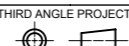
THIS DRAWING CONTAINS INFORMATION THAT IS PROPRIETARY TO MOLEX ELECTRONIC TECHNOLOGIES, LLC AND SHOULD NOT BE USED WITHOUT WRITTEN PERMISSION											
DIMENSION UNITS		SCALE		CURRENT REV DESC: SH_04 & 05 UPDATED							
mm		NTS		EC NO: 177265							
GENERAL TOLERANCES (UNLESS SPECIFIED)				DRWN: RLALSANGI		2018/05/16		CUSTOM HEADER			
				CHK'D: MBELLE		2018/05/25		2.54MM PITCH SINGLE ROW SINGLE WAFER SMT HEADER			
				APPR: ISHWARG		2018/06/13		PRODUCT CUSTOMER DRAWING			
4 PLACES ±				INITIAL REVISION:		DRWN: SKLIM01		DOCUMENT NUMBER		DOC TYPE	
3 PLACES ±				DRWN: SKLIM01		2005/10/26		SD-87898-003		PSD	
2 PLACES ± 0.2				APPR: PTLIM		2005/11/07		001		C	
1 PLACE ±				DRAFT WHERE APPLICABLE MUST REMAIN WITHIN DIMENSIONS		THIRD ANGLE PROJECTION		DRAWING		SERIES	
0 PLACES ±								A3-SIZE		87898	
ANGULAR TOL ± 3.0°								MATERIAL NUMBER		CUSTOMER	
								SEE TABLE		GENERAL MARKET	
										SHEET NUMBER	
										16 OF 17	

PACKAGING OPTION PART NO.						CKT SIZE	VOID POSITION	PLATING TYPE	DIMENSION			
TRAY WITHOUT CAP	TRAY WITH CAP	TUBE WITHOUT CAP	TUBE WITH CAP	TAPE & REEL WITHOUT CAP	TAPE & REEL WITH CAP				A	B	F	M
-----	-----	87898-4061	-----	-----	-----	40	----	1	101.6	99.06	11.94	8.13
-----	-----	87898-4062	-----	-----	-----	40	----	2	101.6	99.06	11.94	8.13
-----	-----	87898-4064	-----	-----	-----	40	----	4	101.6	99.06	11.94	8.13
-----	-----	87898-4065	-----	-----	-----	40	----	5	101.6	99.06	11.94	8.13
-----	-----	87898-4066	-----	-----	-----	40	----	6	101.6	99.06	11.94	8.13

THIS DRAWING CONTAINS INFORMATION THAT IS PROPRIETARY TO MOLEX ELECTRONIC TECHNOLOGIES, LLC AND SHOULD NOT BE USED WITHOUT WRITTEN PERMISSION											
DIMENSION UNITS		SCALE		CURRENT REV DESC: SH_04 & 05 UPDATED						<b>molex</b>	
mm		NTS									
GENERAL TOLERANCES (UNLESS SPECIFIED)						EC NO: 177265		CUSTOM HEADER			
						DRWN: RLALSANGI		2018/05/16		2.54MM PITCH SINGLE ROW SINGLE WAFER SMT HEADER	
4 PLACES ±		±				CHK'D: MBELLE		2018/05/25		PRODUCT CUSTOMER DRAWING	
3 PLACES ±		±				APPR: ISHWARG		2018/06/13			
2 PLACES ±		0.2 ±				INITIAL REVISION:		DOCUMENT NUMBER			
1 PLACE ±		±				DRWN: SKLIM01		2005/10/26		SD-87898-003	
0 PLACES ±		±				APPR: PTLIM		2005/11/07		PSD 001 C	
ANGULAR TOL ±		3.0°									
DRAFT WHERE APPLICABLE MUST REMAIN WITHIN DIMENSIONS				THIRD ANGLE PROJECTION		DRAWING		SERIES		SHEET NUMBER	
						A3-SIZE		87898		17 OF 17	