

**DIMENSIONS FOR LARGE POLARIZATION RIB TERMINAL ONLY**

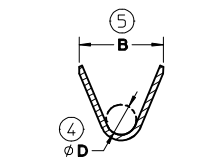

**SECTION B-B  
SCALE 5:1**

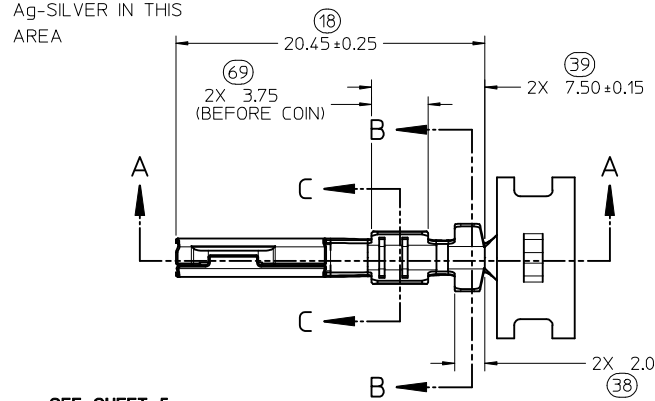
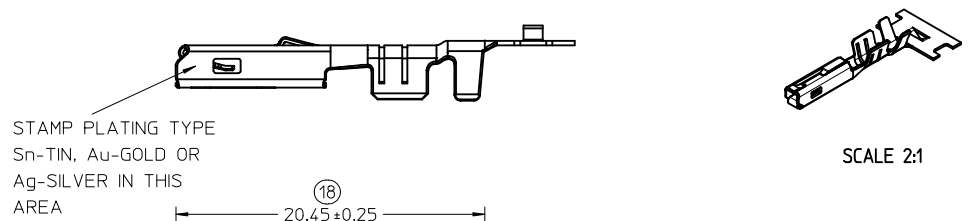
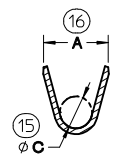

**SECTION C-C  
SCALE 5:1**

NOTES: (UNLESS OTHERWISE SPECIFIED)

1. MATING TERMINAL SHOWN ON SD-33000-001
2. MATERIAL: ASTM B422, UNS C19025, HR04  
THICKNESS: 0.30 mm +0.01  
TEMPER: FULL HARD (REF)  
TENSILE: 496 MIN MPA
3. TIN PLATED TERMINAL FINISH:  
OVERALL UNDERPLATE ELECTRODEPOSITED NICKEL  
OVERALL ELECTRODEPOSITED REFLOW TIN
4. GOLD PLATED TERMINAL FINISH:  
OVERALL UNDERPLATE ELECTRODEPOSITED DUCTILE SULFAMATE NICKEL  
CONTACT AREA - ELECTRODEPOSITED GOLD  
GRIP AREA - ELECTRODEPOSITED 100% TIN MATTE FINISH
5. SILVER PLATED TERMINAL FINISH:  
OVERALL UNDERPLATE ELECTRODEPOSITED DUCTILE SULFAMATE NICKEL  
CONTACT AREA - ELECTRODEPOSITED PURE SILVER (0.5% MAX IMPURITIES) SEMI-BRIGHT FINISH  
- SILVER ANTI-TARNISH : EVABRITE  
GRIP AREA - ELECTRODEPOSITED 100% TIN MATTE FINISH
6. MEETS PERFORMANCE SPECIFICATION FOR CABLE TO TERMINAL ELECTRICAL CRIMPS PER SAE/USCAR-21 (8/2001)
7. MEETS PERFORMANCE STANDARD FOR AUTOMOTIVE ELECTRICAL CONNECTOR SYSTEMS FOR SAE/USCAR-2, REV. 4 (TEMP CLASS 3) (5/2004)
8. MEETS ELECTRICAL CONNECTION SYSTEM DESIGN SPECIFICATION (SDS) REV.11 (5/2002)
9. MEETS FIELD CORRELATED LIFE TEST (FCLT) PER SAE/USCAR-20 (6/2004)
10. MEETS WIRING COMPONENT DESIGN GUIDELINES SAE/USCAR-12 REV 2 (12/2001)
11. TSC ON A DIMENSION TO BE INTERPRETED AS DISTANCE TO A THEORETICAL SHARP CORNER AS IF THE RADIUS WERE NOT PRESENT
12. REFERENCE 97BG-14474-AAB FOR LARGE POLARIZATION RIB CAVITY SPECIFICATION
13. INSERTION FORCE (TINI) AVG. FROM PV TESTING -  
3.8N LARGE POLARIZATION RIB  
3.5N SMALL POLARIZATION RIB (REFERENCE)
14. ALL DIMENSIONS EXCEPT (33), (34), (41) & (42) ARE COMMON TO BOTH SMALL AND LARGE POLARIZATION RIB TERMINALS
15. REFERENCE PK-31300-516 FOR REEL DIRECTION
16. REFERENCE AS-33012-002 FOR CRIMP INFORMATION

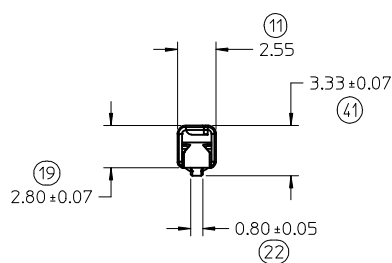

**SEE SHEET 5  
FOR M3 GRIP CODE  
TERMINAL**

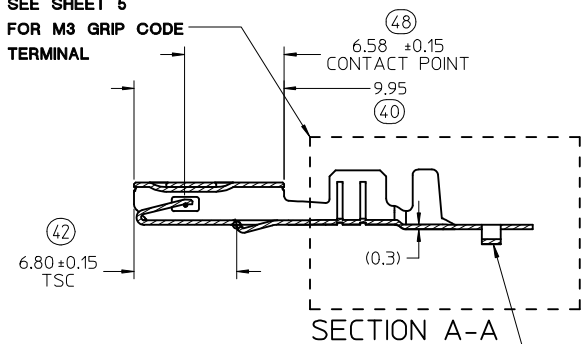

CARRIER BUMP DIRECTION  
POINTS DOWN FOR TIN PLATED TERMINALS  
POINTS UP FOR PRECIOUS PLATED TERMINALS

(10.67)  
PROGRESSION

<b>ENTER DESCRIPTION</b> EC NO: UAU2017-1076 DRW: NANKATESHSH2017/05/29 CHK: D.A., DHIR 2017/05/29 APPR: T.JSMITH 2017/06/09	QUALITY SYMBOLS ∇=0 ∇=0 ∇=0	GENERAL TOLERANCES (UNLESS SPECIFIED)		DIMENSION STYLE <b>MM ONLY</b>	SCALE <b>4:1</b>	DESIGN UNITS <b>METRIC</b>	THIRD ANGLE PROJECTION	
		4 PLACES ± --- ± --- 3 PLACES ± --- ± --- 2 PLACES ± 0.10 ± --- 1 PLACE ± 0.3 ± --- 0 PLACE ± ±	mm INCH	DRAWN BY DATE L. PULLIAM 2005/06/21	CHECKED BY DATE A. DHIR 2005/06/21	TITLE <h2 style="text-align: center;">MX150 RECEPTACLE TERMINAL</h2>		
ANGULAR ± 3 °		MATERIAL NO. <b>SEE TABLE</b>		DOCUMENT NO. <b>SD-33012-002</b>				
DRAFT WHERE APPLICABLE MUST REMAIN WITHIN DIMENSIONS		THIS DRAWING CONTAINS INFORMATION THAT IS PROPRIETARY TO MOLEX INCORPORATED AND SHOULD NOT BE USED WITHOUT WRITTEN PERMISSION						

FAMILY	GENDER	SEALING	PLATING	PART NUMBER	PAYOFF DIRECTION	GRIP CODE	WIRE SIZES*	A ±0.30	B ±0.30	C ±0.30	D ±0.30	SPECIAL CHARACTERISTICS
MX150	RECEPTACLE	MAT SEAL	Sn	33012-2001	RIGHT (B)	14	16/14AWG	3.9	4.4	1.7	1.6	HIGH PERFORMANCE Sn
				33012-3001	LEFT (D)		1.50-2.00mm <sup>2</sup>					
				33012-2002	RIGHT (B)	18	20/18AWG	3.3	3.1	1.3	1.4	
				33012-3002	LEFT (D)		0.75-1.00mm <sup>2</sup>					
				33012-2003	RIGHT (B)	22	22AWG	2.5	2.6	0.9	1.0	
				33012-3003	LEFT (D)							
			33012-2004	RIGHT (B)	M3	0.35-0.50mm <sup>2</sup>	2.5	2.7	0.9	1.54 ±0.1		
			33012-3004	LEFT (D)								
			33001-2003	RIGHT (B)	14	16/14AWG	3.9	4.4	1.7	1.6	HIGH PERFORMANCE Au	
			33001-3003	LEFT (D)		1.50-2.00mm <sup>2</sup>						
			33001-2004	RIGHT (B)	18	20/18AWG	3.3	3.1	1.3	1.4		
			33001-3004	LEFT (D)		0.75-1.00mm <sup>2</sup>						
			33001-2005	RIGHT (B)	22	22AWG	2.5	2.6	0.9	1.0		
			33001-3005	LEFT (D)								
			33001-2006	RIGHT (B)	M3	0.35-0.50mm <sup>2</sup>	2.5	2.7	0.9	1.54 ±0.1		
			33001-3006	LEFT (D)								
			33001-4001	RIGHT (B)	14	16/14AWG	3.9	4.4	1.7	1.6	HIGH PERFORMANCE Ag	
			33001-5001	LEFT (D)		1.50-2.00mm <sup>2</sup>						
33001-4002	RIGHT (B)	18	20/18AWG	3.3	3.1	1.3	1.4					
33001-5002	LEFT (D)		0.75-1.00mm <sup>2</sup>									
33001-4003	RIGHT (B)	22	22AWG	2.5	2.6	0.9	1.0					
33001-5003	LEFT (D)											
33001-4005	RIGHT (B)	M3	0.35-0.50mm <sup>2</sup>	2.5	2.7	0.9	1.54 ±0.1					
33001-5005	LEFT (D)											

LARGE POLARIZATION RIB - NOT TO BE USED IN MX150 SEALED CONNECTORS

FAMILY	GENDER	SEALING	PLATING	PART NUMBER	PAYOFF DIRECTION	GRIP CODE	WIRE SIZES*	A ±0.30	B ±0.30	C ±0.30	D ±0.30	SPECIAL CHARACTERISTICS
MX150	RECEPTACLE	UNSEALED	Sn	33012-2021	RIGHT (B)	14	16/14AWG	3.9	4.4	1.7	1.6	HIGH PERFORMANCE Sn
				33012-3021	LEFT (D)		1.50-2.00mm <sup>2</sup>					
				33012-2022	RIGHT (B)	18	20/18AWG	3.3	3.1	1.3	1.4	
				33012-3022	LEFT (D)		0.75-1.00mm <sup>2</sup>					
				33012-2023	RIGHT (B)	22	22AWG	2.5	2.6	0.9	1.0	
				33012-3023	LEFT (D)		0.35-0.50mm <sup>2</sup>					
			33001-2021	RIGHT (B)	14	16/14AWG	3.9	4.4	1.7	1.6	HIGH PERFORMANCE Au	
			33001-3021	LEFT (D)		1.50-2.00mm <sup>2</sup>						
			33001-2022	RIGHT (B)	18	20/18AWG	3.3	3.1	1.3	1.4		
			33001-3022	LEFT (D)		0.75-1.00mm <sup>2</sup>						
			33001-2023	RIGHT (B)	22	22AWG	2.5	2.6	0.9	1.0		
			33001-3023	LEFT (D)		0.35-0.50mm <sup>2</sup>						
			33001-4021	RIGHT (B)	14	16/14AWG	3.9	4.4	1.7	1.6	HIGH PERFORMANCE Ag	
			33001-5021	LEFT (D)		1.50-2.00mm <sup>2</sup>						
			33001-4022	RIGHT (B)	18	20/18AWG	3.3	3.1	1.3	1.4		
			33001-5022	LEFT (D)		0.75-1.00mm <sup>2</sup>						
			33001-4023	RIGHT (B)	22	22AWG	2.5	2.6	0.9	1.0		
			33001-5023	LEFT (D)		0.35-0.50mm <sup>2</sup>						

\* REFERENCE AS-33012-002 FOR SPECIFIC WIRE TYPES

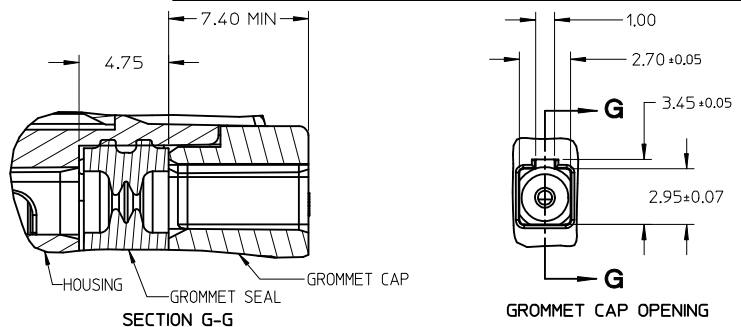

**GROMMET SEAL / CAP CONFIGURATION TO MODIFY LARGE POLARIZATION RIB CAVITY TO ACCEPT SMALL POLARIZATION RIB APPLICATIONS**

<b>ENTER DESCRIPTION</b> EC NO: JAU2017-1076 DRW:WENKATESHSH2017/05/29 CHK:DA. DHIR 2017/05/29 APPR:JSMITH 2017/06/09 REV: C1	<b>QUALITY SYMBOLS</b> ▽=0 ▽=0 ▽=0	<b>GENERAL TOLERANCES (UNLESS SPECIFIED)</b>		<b>DIMENSION STYLE</b> MM ONLY		SCALE METRIC	DESIGN UNITS METRIC	THIRD ANGLE PROJECTION	
		mm      INCH		DRAWN BY      DATE L. PULLIAM      2005/06/21		TITLE MX150 RECEPTACLE TERMINAL			
		4 PLACES ± --- ± --- 3 PLACES ± --- ± --- 2 PLACES ± 0.10 ± --- 1 PLACE ± 0.3 ± --- 0 PLACE ±      ±		CHECKED BY      DATE A. DHIR      2005/06/21		APPROVED BY      DATE B. MOSER      2005/06/22			
		ANGULAR ± 3 °		MATERIAL NO. SEE TABLE		DOCUMENT NO. SD-33012-002		SHEET NO. 2 OF 5	
DRAFT WHERE APPLICABLE MUST REMAIN WITHIN DIMENSIONS				THIS DRAWING CONTAINS INFORMATION THAT IS PROPRIETARY TO MOLEX INCORPORATED AND SHOULD NOT BE USED WITHOUT WRITTEN PERMISSION					

THIS CHECKING - AID IS FOR SMALL POLARIZATION RIB TERMINALS ONLY

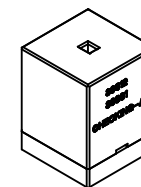

CHECKING - AID ASSEMBLY  
SCALE 1:1

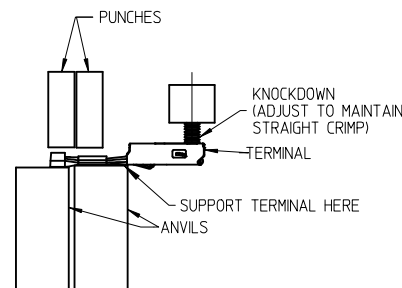
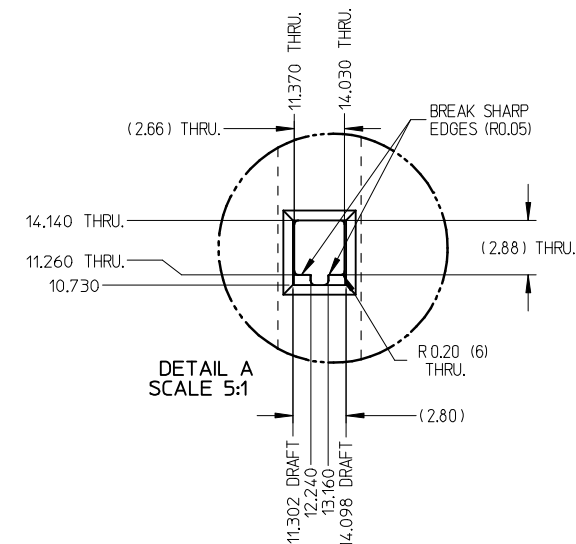
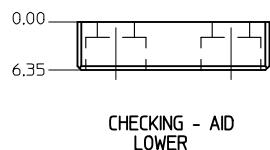
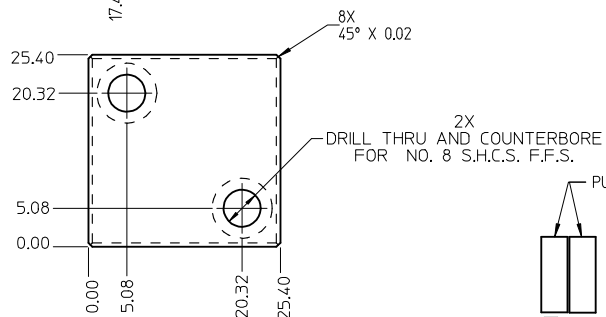
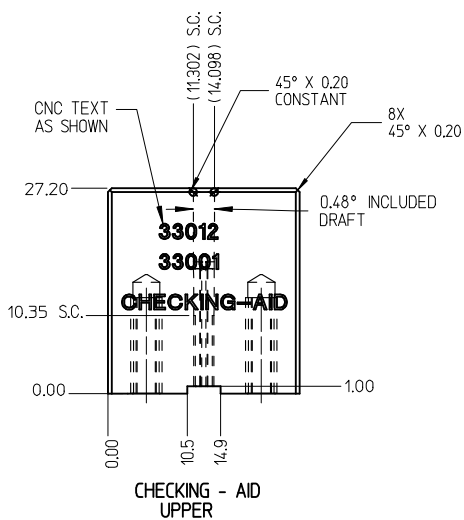
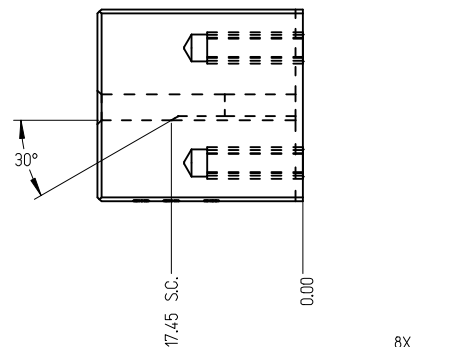
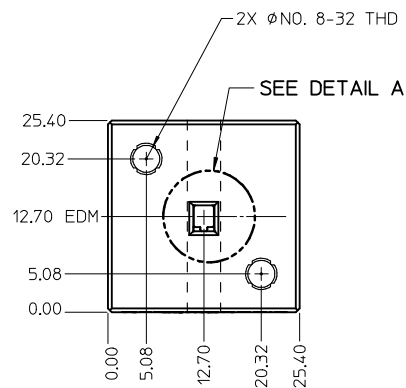

CRIMP REQUIREMENTS:

1. CRIMP STRAIGHTNESS MUST BE MAINTAINED USE A KNOCKDOWN TOOL LOCATED AS SHOWN TERMINAL BOX MUST NOT BE DEFORMED
2. AFTER CRIMPING, THE CRIMPED TERMINAL (AND UP TO 5 mm OF WIRE PAST THE INSULATOR CUTOFF TAB) MUST FIT FREELY INTO THE CHECKING-AID SHOWN ON THIS PAGE
3. FOR OTHER MECHANICAL REQUIREMENTS ON CRIMPED TERMINALS, REFER TO SAE/USCAR-21 (5-13-02) SECTIONS 4.2 (VISUAL INSPECTION), 4.2 (CROSS SECTION ANALYSIS) AND 4.4 (CONDUCTOR CRIMP PULLOUT FORCE)

UPPER & LOWER  
CHECKING-AID  
A2 TOOL STEEL  
HARDEN & GRIND  
ROCKWELL "C" 56-58

<b>ENTER DESCRIPTION</b> EC NO: UAU2017-1076 DRWN:WENKATESHSH2017/05/29 CHKD:A. DHIR 2017/05/29 APPR:T.JSMITH 2017/06/09	<b>QUALITY SYMBOLS</b> 	<b>GENERAL TOLERANCES (UNLESS SPECIFIED)</b>		DIMENSION STYLE <b>MM ONLY</b>	SCALE <b>2:1</b>	DESIGN UNITS <b>METRIC</b>	THIRD ANGLE PROJECTION	
		4 PLACES ± --- ± --- 3 PLACES ± --- ± --- 2 PLACES ± 0.10 ± --- 1 PLACE ± 0.3 ± --- 0 PLACE ± ±	mm INCH	DRAWN BY DATE L. PULLIAM 2005/06/21	CHECKED BY DATE A. DHIR 2005/06/21	MX150 RECEPTACLE TERMINAL  <b>molex</b>  DOCUMENT NO. SD-33012-002 SHEET NO. 3 OF 5		
ANGULAR ± 3 °		MATERIAL NO. <b>SEE TABLE</b>	THIS DRAWING CONTAINS INFORMATION THAT IS PROPRIETARY TO MOLEX. INCORPORATED AND SHOULD NOT BE USED WITHOUT WRITTEN PERMISSION					
<b>C1</b>	<b>DESCRIPTION</b>	DRAFT WHERE APPLICABLE MUST REMAIN WITHIN DIMENSIONS		SIZE <b>C</b>				

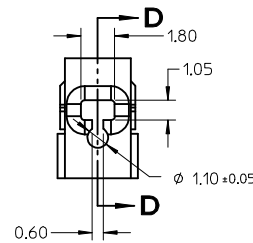
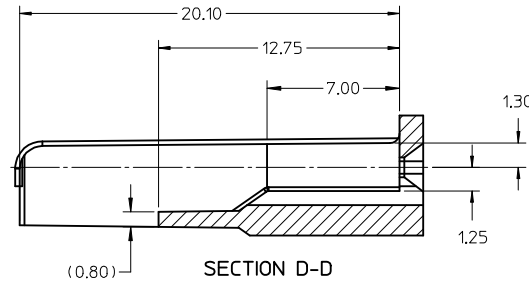
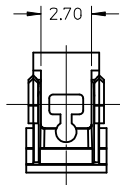

NOTES: UNLESS OTHERWISE SPECIFIED

1. TOLERANCES: LINEAR  $\pm 0.10$   
ANGULAR  $\pm 3^\circ$
2. ALL DRAFT WITHIN TOLERANCE.
3. MAX RADII ON ALL CORNERS SHOWN SHARP: 0.10
4. MAX FLASH PERMISSIBLE: 0.1
5. EJECTOR PIN MARKS PERMISSIBLE IF FLUSH TO 0.25 BELOW SURFACE.
6. MATERIAL: HOUSING/FINGER SPECIFICATION ENGINEERED FOR MATERIAL WITH THE FOLLOWING PROPERTIES:  
A. FLEXURAL MODULUS = 4,500 TO 9,400 MPa  
PER ASTM TEST D790  
B. ELONGATION AT YIELD = 2.3% OR BETTER  
PER ASTM TEST D638 TYPE V
7. CAVITY SPEC FOR USE ONLY WITH MOLEX RECEPTACLE  
TERMINAL PART NUMBERS SPECIFIED ELSEWHERE ON THIS  
DRAWING

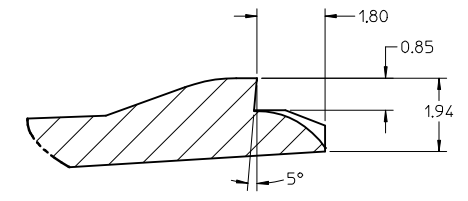
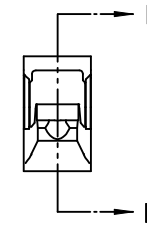
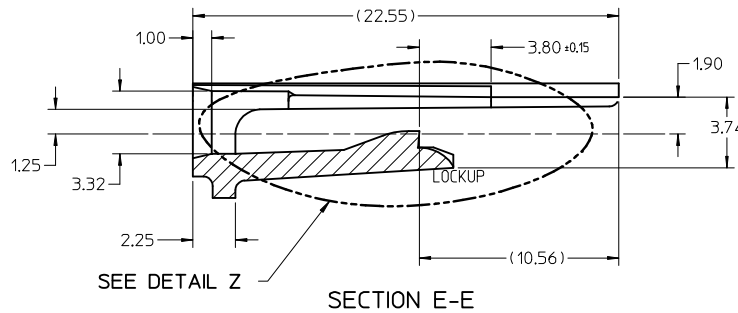
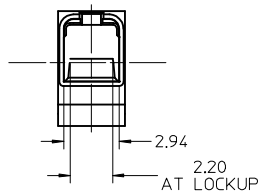

DETAIL Z  
SCALE 20:1

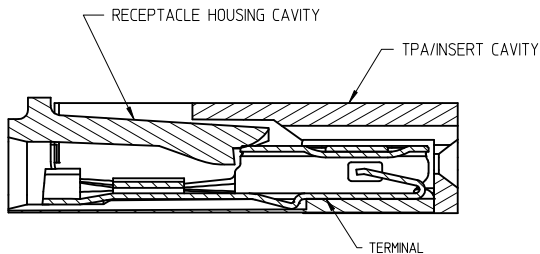

SECTION F-F

RECEPTACLE CAVITY ASSEMBLED VIEWS  
FOR SMALL POLARIZATION RIB APPLICATIONS  
FIG. 1

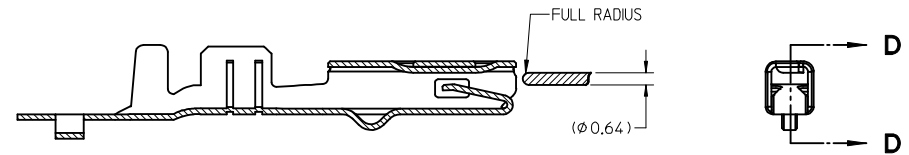
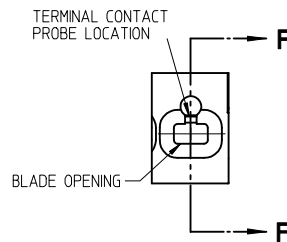

SECTION D-D  
FOR LARGE POLARIZATION RIB APPLICATIONS  
FIG. 2

PROBING DOWN THE  
THROAT MUST USE  
THIS TERMINAL PROBE

FOR PROBING INFORMATION REFERENCE  
MOLEX MX150 APPLICATION SPEC AS-33472-100

PREFERRED PROBING LOCATION  
IS NOT ON SPRING MEMBER

IF ELECTRICAL CONTINUITY PROBE  
TOUCHES SPRING MEMBER USE  
PROBING AS SHOWN IN FIG. 2

ENTER DESCRIPTION EC NO: UAU2017-1076 DRAWN: VENKATESHSH/2017/05/29 CHKD: A. DHIR 2017/05/29 APPR: T.JSMITH 2017/06/09	QUALITY SYMBOLS ▽=0 ▽=0 ▽=0	GENERAL TOLERANCES (UNLESS SPECIFIED)		DIMENSION STYLE <b>MM ONLY</b>	SCALE <b>5:1</b>	DESIGN UNITS <b>METRIC</b>	THIRD ANGLE PROJECTION
		4 PLACES ± --- ± ---	3 PLACES ± --- ± ---	DRAWN BY DATE L. PULLIAM 2005/06/21	TITLE <b>MX150 RECEPTACLE TERMINAL</b>		
C1	DESCRIPTION REV	2 PLACES ± 0.10 ± ---	1 PLACE ± 0.3 ± ---	CHECKED BY DATE A. DHIR 2005/06/21	DOCUMENT NO. <b>SD-33012-002</b>		
		0 PLACE ± ±	ANGULAR ± 3°	APPROVED BY DATE B. MOSER 2005/06/22			
DRAFT WHERE APPLICABLE MUST REMAIN WITHIN DIMENSIONS		MATERIAL NO. <b>SEE TABLE</b>		THIS DRAWING CONTAINS INFORMATION THAT IS PROPRIETARY TO MOLEX INCORPORATED AND SHOULD NOT BE USED WITHOUT WRITTEN PERMISSION			

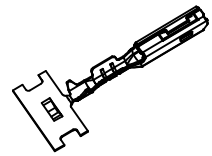

ISO VIEW  
SCALE 2:1

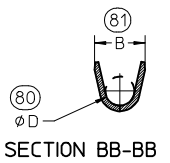
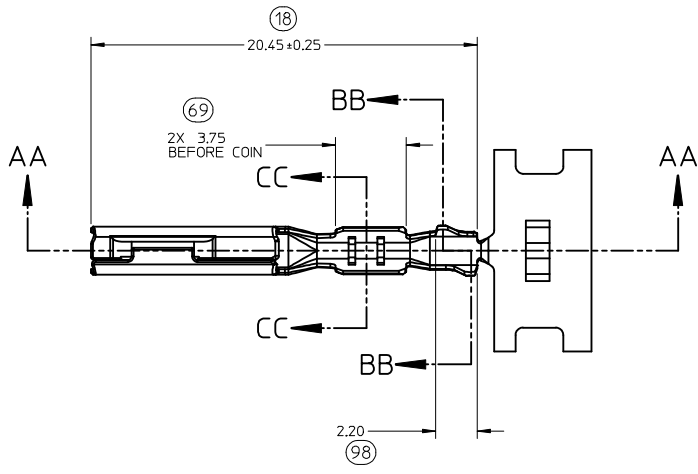

SECTION BB-BB

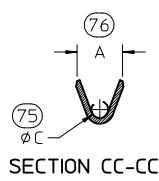

SECTION CC-CC

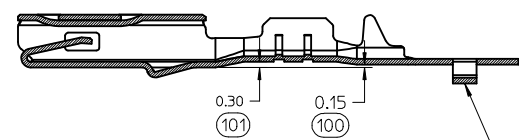
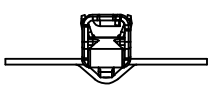

SECTION AA-AA  
**M3 GRIP CODE TERMINAL**  
SEE TABLE (SHEET 2) FOR PART NUMBERS

CARRIER BUMP DIRECTION  
POINTS DOWN FOR TIN PLATED TERMINAL  
POINTS UP FOR PRECIOUS METAL PLATED TERMINAL

<b>ENTER DESCRIPTION</b> EC NO: UAU2017-1076 DRW: N VENKATESH 2017/05/29 CHKD: A. DHIR 2017/05/29 APPR: T. J. SMITH 2017/06/09	QUALITY SYMBOLS ▽=0 ▽=0 ▽=0	GENERAL TOLERANCES (UNLESS SPECIFIED)		DIMENSION STYLE <b>MM ONLY</b>	SCALE <b>5:1</b>	DESIGN UNITS <b>METRIC</b>	THIRD ANGLE PROJECTION		
		4 PLACES ± --- ± ---	3 PLACES ± --- ± ---	2 PLACES ± 0.10 ± ---	1 PLACE ± 0.3 ± ---	DRAWN BY L. PULLIAM	DATE 2005/06/21	TITLE <b>MX150 RECEPTACLE TERMINAL</b>	
		ANGULAR ± 3°		DRAFT WHERE APPLICABLE MUST REMAIN WITHIN DIMENSIONS		CHECKED BY A. DHIR	DATE 2005/06/21	MOLEX INCORPORATED	
		MATERIAL NO. <b>SEE TABLE</b>		DOCUMENT NO. <b>SD-33012-002</b>		SHEET NO. <b>5 OF 5</b>		THIS DRAWING CONTAINS INFORMATION THAT IS PROPRIETARY TO MOLEX INCORPORATED AND SHOULD NOT BE USED WITHOUT WRITTEN PERMISSION	

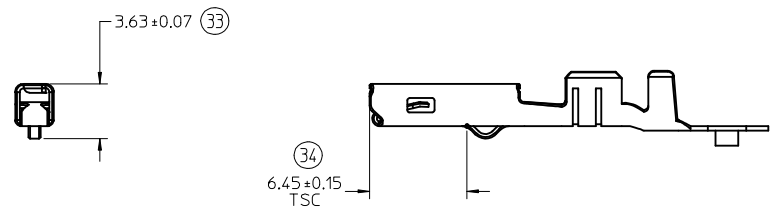

**DIMENSIONS FOR LARGE POLARIZATION RIB TERMINAL ONLY**

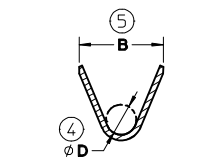
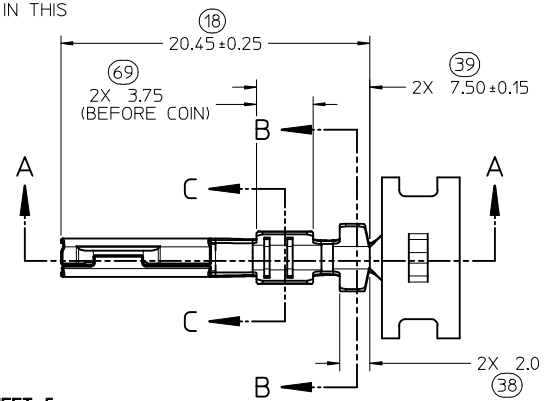
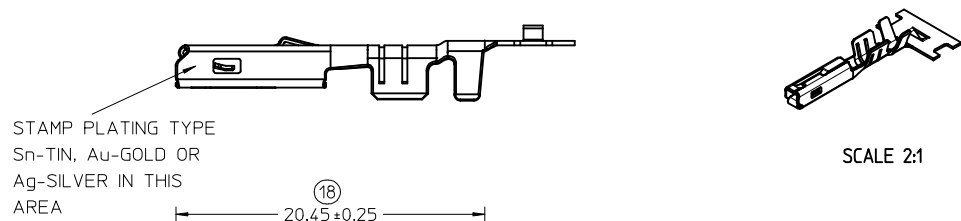

**SECTION B-B SCALE 5:1**

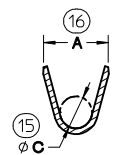

**SECTION C-C SCALE 5:1**

CARRIER BUMP DIRECTION  
POINTS DOWN FOR TIN PLATED TERMINALS  
POINTS UP FOR PRECIOUS PLATED TERMINALS

NOTES: (UNLESS OTHERWISE SPECIFIED)

1. MATING TERMINAL SHOWN ON SD-33000-001
2. MATERIAL: ASTM B422, UNS C19025, HR04  
THICKNESS: 0.30 mm +0.01  
TEMPER: FULL HARD (REF)  
TENSILE: 496 MIN MPA
3. TIN PLATED TERMINAL FINISH:  
OVERALL UNDERPLATE ELECTRODEPOSITED NICKEL  
OVERALL ELECTRODEPOSITED REFLOW TIN
4. GOLD PLATED TERMINAL FINISH  
OVERALL UNDERPLATE ELECTRODEPOSITED DUCTILE SULFAMATE NICKEL  
CONTACT AREA - ELECTRODEPOSITED GOLD  
GRIP AREA - ELECTRODEPOSITED 100% TIN MATTE FINISH
5. SILVER PLATED TERMINAL FINISH  
OVERALL UNDERPLATE ELECTRODEPOSITED DUCTILE SULFAMATE NICKEL  
CONTACT AREA - ELECTRODEPOSITED PURE SILVER (0.5% MAX IMPURITIES) SEMI-BRIGHT FINISH  
- SILVER ANTI-TARNISH : EVABRITE  
GRIP AREA - ELECTRODEPOSITED 100% TIN MATTE FINISH
6. MEETS PERFORMANCE SPECIFICATION FOR CABLE TO TERMINAL ELECTRICAL CRIMPS PER SAE/USCAR-21 (8/2001)
7. MEETS PERFORMANCE STANDARD FOR AUTOMOTIVE ELECTRICAL CONNECTOR SYSTEMS FOR SAE/USCAR-2, REV. 4 (TEMP CLASS 3) (5/2004)
8. MEETS ELECTRICAL CONNECTION SYSTEM DESIGN SPECIFICATION (SDS) REV.11 (5/2002)
9. MEETS FIELD CORRELATED LIFE TEST (FCLT) PER SAE/USCAR-20 (6/2004)
10. MEETS WIRING COMPONENT DESIGN GUIDELINES SAE/USCAR-12 REV 2 (12/2001)
11. TSC ON A DIMENSION TO BE INTERPRETED AS DISTANCE TO A THEORETICAL SHARP CORNER AS IF THE RADIUS WERE NOT PRESENT
12. REFERENCE 97BG-14474-AAB FOR LARGE POLARIZATION RIB CAVITY SPECIFICATION
13. INSERTION FORCE (TINI) AVG. FROM PV TESTING -  
3.8N LARGE POLARIZATION RIB  
3.5N SMALL POLARIZATION RIB (REFERENCE)
14. ALL DIMENSIONS EXCEPT (33), (34), (41) & (42) ARE COMMON TO BOTH SMALL AND LARGE POLARIZATION RIB TERMINALS
15. REFERENCE PK-31300-516 FOR REEL DIRECTION
16. REFERENCE AS-33012-002 FOR CRIMP INFORMATION

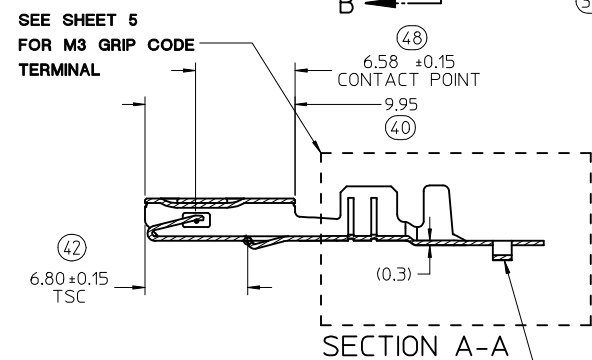
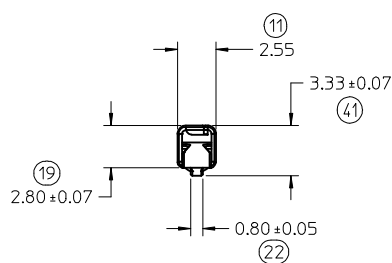

SEE SHEET 5  
FOR M3 GRIP CODE  
TERMINAL

(10.67)  
PROGRESSION

<b>ENTER DESCRIPTION</b> EC NO: UAU2017-1076 DRW: NANKATESHSH/2017/05/29 CHK: D.A., DHIR 2017/05/29 APPR: T.JSM/TH 2017/06/09 (REV)	QUALITY SYMBOLS ∇=0 ∇=0 ∇=0	GENERAL TOLERANCES (UNLESS SPECIFIED)		DIMENSION STYLE <b>MM ONLY</b>		SCALE 4:1	DESIGN UNITS METRIC	THIRD ANGLE PROJECTION	
		4 PLACES ± --- ± --- 3 PLACES ± --- ± --- 2 PLACES ± 0.10 ± --- 1 PLACE ± 0.3 ± --- 0 PLACE ± ±	mm INCH	DRAWN BY DATE L. PULLIAM 2005/06/21	CHECKED BY DATE A. DHIR 2005/06/21	APPROVED BY DATE B. MOSER 2005/06/22		TITLE <b>MX150 RECEPTACLE TERMINAL</b>	
DRAFT WHERE APPLICABLE MUST REMAIN WITHIN DIMENSIONS		ANGULAR ± 3°		MATERIAL NO. <b>SEE TABLE</b>		DOCUMENT NO. <b>SD-33012-002</b>		SHEET NO. 1 OF 5	
THIS DRAWING CONTAINS INFORMATION THAT IS PROPRIETARY TO MOLEX INCORPORATED AND SHOULD NOT BE USED WITHOUT WRITTEN PERMISSION									

FAMILY	GENDER	SEALING	PLATING	PART NUMBER	PAYOFF DIRECTION	GRIP CODE	WIRE SIZES*	A ±0.30	B ±0.30	C ±0.30	D ±0.30	SPECIAL CHARACTERISTICS
MX150	RECEPTACLE	MAT SEAL	Sn	33012-2001	RIGHT (B)	14	16/14AWG	3.9	4.4	1.7	1.6	HIGH PERFORMANCE Sn
				33012-3001	LEFT (D)		1.50-2.00mm <sup>2</sup>					
				33012-2002	RIGHT (B)	18	20/18AWG	3.3	3.1	1.3	1.4	
				33012-3002	LEFT (D)		0.75-1.00mm <sup>2</sup>					
				33012-2003	RIGHT (B)	22	22AWG	2.5	2.6	0.9	1.0	
				33012-3003	LEFT (D)							
			33012-2004	RIGHT (B)	M3	0.35-0.50mm <sup>2</sup>	2.5	2.7	0.9	1.54 ±0.1		
			33012-3004	LEFT (D)								
			33001-2003	RIGHT (B)	14	16/14AWG	3.9	4.4	1.7	1.6	HIGH PERFORMANCE Au	
			33001-3003	LEFT (D)		1.50-2.00mm <sup>2</sup>						
			33001-2004	RIGHT (B)	18	20/18AWG	3.3	3.1	1.3	1.4		
			33001-3004	LEFT (D)		0.75-1.00mm <sup>2</sup>						
			33001-2005	RIGHT (B)	22	22AWG	2.5	2.6	0.9	1.0		
			33001-3005	LEFT (D)								
			33001-2006	RIGHT (B)	M3	0.35-0.50mm <sup>2</sup>	2.5	2.7	0.9	1.54 ±0.1		
			33001-3006	LEFT (D)								
			33001-4001	RIGHT (B)	14	16/14AWG	3.9	4.4	1.7	1.6	HIGH PERFORMANCE Ag	
			33001-5001	LEFT (D)		1.50-2.00mm <sup>2</sup>						
33001-4002	RIGHT (B)	18	20/18AWG	3.3	3.1	1.3	1.4					
33001-5002	LEFT (D)		0.75-1.00mm <sup>2</sup>									
33001-4003	RIGHT (B)	22	22AWG	2.5	2.6	0.9	1.0					
33001-5003	LEFT (D)											
33001-4005	RIGHT (B)	M3	0.35-0.50mm <sup>2</sup>	2.5	2.7	0.9	1.54 ±0.1					
33001-5005	LEFT (D)											

LARGE POLARIZATION RIB - NOT TO BE USED IN MX150 SEALED CONNECTORS

FAMILY	GENDER	SEALING	PLATING	PART NUMBER	PAYOFF DIRECTION	GRIP CODE	WIRE SIZES*	A ±0.30	B ±0.30	C ±0.30	D ±0.30	SPECIAL CHARACTERISTICS
MX150	RECEPTACLE	UNSEALED	Sn	33012-2021	RIGHT (B)	14	16/14AWG	3.9	4.4	1.7	1.6	HIGH PERFORMANCE Sn
				33012-3021	LEFT (D)		1.50-2.00mm <sup>2</sup>					
				33012-2022	RIGHT (B)	18	20/18AWG	3.3	3.1	1.3	1.4	
				33012-3022	LEFT (D)		0.75-1.00mm <sup>2</sup>					
				33012-2023	RIGHT (B)	22	22AWG	2.5	2.6	0.9	1.0	
				33012-3023	LEFT (D)		0.35-0.50mm <sup>2</sup>					
			33001-2021	RIGHT (B)	14	16/14AWG	3.9	4.4	1.7	1.6	HIGH PERFORMANCE Au	
			33001-3021	LEFT (D)		1.50-2.00mm <sup>2</sup>						
			33001-2022	RIGHT (B)	18	20/18AWG	3.3	3.1	1.3	1.4		
			33001-3022	LEFT (D)		0.75-1.00mm <sup>2</sup>						
			33001-2023	RIGHT (B)	22	22AWG	2.5	2.6	0.9	1.0		
			33001-3023	LEFT (D)		0.35-0.50mm <sup>2</sup>						
			33001-4021	RIGHT (B)	14	16/14AWG	3.9	4.4	1.7	1.6	HIGH PERFORMANCE Ag	
			33001-5021	LEFT (D)		1.50-2.00mm <sup>2</sup>						
			33001-4022	RIGHT (B)	18	20/18AWG	3.3	3.1	1.3	1.4		
			33001-5022	LEFT (D)		0.75-1.00mm <sup>2</sup>						
			33001-4023	RIGHT (B)	22	22AWG	2.5	2.6	0.9	1.0		
			33001-5023	LEFT (D)		0.35-0.50mm <sup>2</sup>						

\* REFERENCE AS-33012-002 FOR SPECIFIC WIRE TYPES

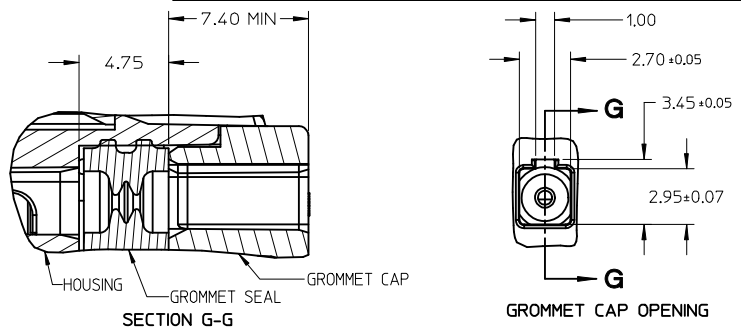

**GROMMET SEAL / CAP CONFIGURATION TO MODIFY LARGE POLARIZATION RIB CAVITY TO ACCEPT SMALL POLARIZATION RIB APPLICATIONS**

<b>ENTER DESCRIPTION</b> EC NO: JAU2017-1076 DRW:WENKATESHSH2017/05/29 CHK:DA. DHIR 2017/05/29 APPR:JSMITH 2017/06/09	QUALITY SYMBOLS ▽=0 ▽=0 ▽=0	GENERAL TOLERANCES (UNLESS SPECIFIED)		DIMENSION STYLE <b>MM ONLY</b>		SCALE	DESIGN UNITS METRIC	THIRD ANGLE PROJECTION			
		4 PLACES ± --- ± --- 3 PLACES ± --- ± --- 2 PLACES ± 0.10 ± --- 1 PLACE ± 0.3 ± --- 0 PLACE ± ±	mm INCH --- --- --- --- --- --- --- --- --- ---	DRAWN BY L. PULLIAM	DATE 2005/06/21	TITLE MX150 RECEPTACLE TERMINAL					
		DRAFT WHERE APPLICABLE MUST REMAIN WITHIN DIMENSIONS		CHECKED BY A. DHIR	DATE 2005/06/21	APPROVED BY B. MOSER					
		C1	REV	ANGULAR ± 3 °		MATERIAL NO. SEE TABLE		DOCUMENT NO. SD-33012-002	SHEET NO. 2 OF 5		

THIS CHECKING - AID IS FOR SMALL POLARIZATION RIB TERMINALS ONLY

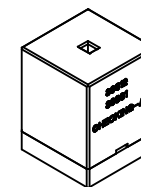

CHECKING - AID ASSEMBLY  
SCALE 1:1

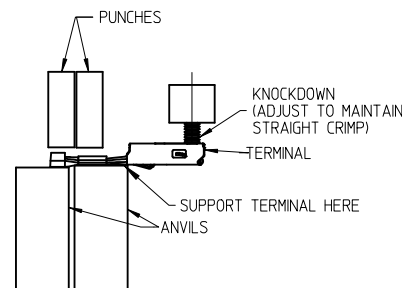
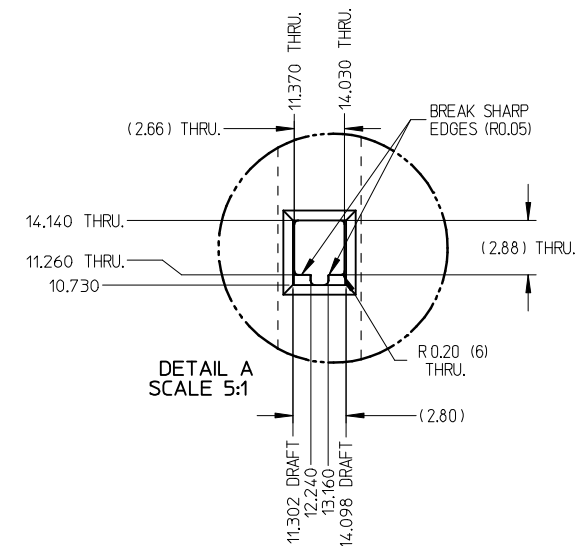
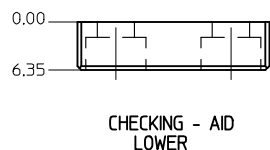
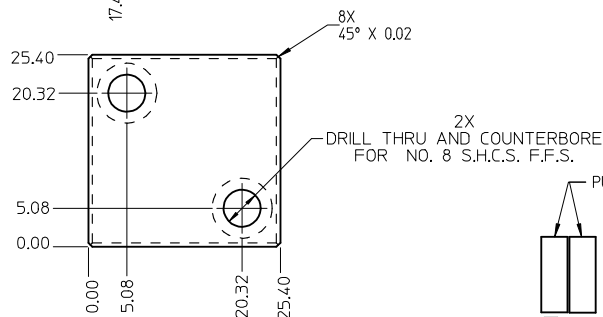
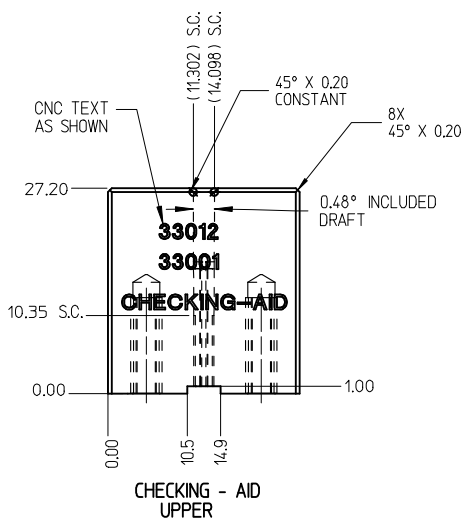
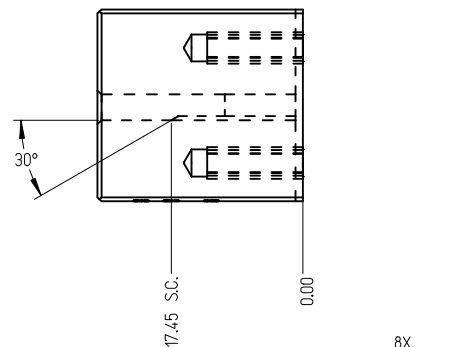
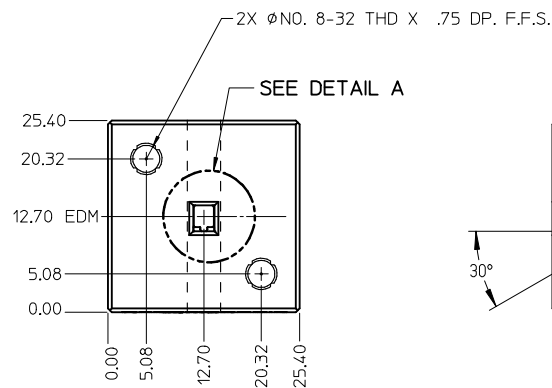

CRIMP REQUIREMENTS:

1. CRIMP STRAIGHTNESS MUST BE MAINTAINED USE A KNOCKDOWN TOOL LOCATED AS SHOWN TERMINAL BOX MUST NOT BE DEFORMED
2. AFTER CRIMPING, THE CRIMPED TERMINAL (AND UP TO 5 mm OF WIRE PAST THE INSULATOR CUTOFF TAB) MUST FIT FREELY INTO THE CHECKING-AID SHOWN ON THIS PAGE
3. FOR OTHER MECHANICAL REQUIREMENTS ON CRIMPED TERMINALS, REFER TO SAE/USCAR-21 (5-13-02) SECTIONS 4.2 (VISUAL INSPECTION), 4.2 (CROSS SECTION ANALYSIS) AND 4.4 (CONDUCTOR CRIMP PULLOUT FORCE)

UPPER & LOWER  
CHECKING-AID  
A2 TOOL STEEL  
HARDEN & GRIND  
ROCKWELL "C" 56-58

<b>ENTER DESCRIPTION</b> EC NO: UAU2017-1076 DRW:WENKATESHSH2017/05/29 CHKD:A. DHIR 2017/05/29 APPR:T.JSMITH 2017/06/09	<b>QUALITY SYMBOLS</b> 	<b>GENERAL TOLERANCES (UNLESS SPECIFIED)</b>		DIMENSION STYLE <b>MM ONLY</b>	SCALE <b>2:1</b>	DESIGN UNITS <b>METRIC</b>	THIRD ANGLE PROJECTION
		4 PLACES ± --- ± --- 3 PLACES ± --- ± --- 2 PLACES ± 0.10 ± --- 1 PLACE ± 0.3 ± --- 0 PLACE ± ±	mm INCH	DRAWN BY DATE L. PULLIAM 2005/06/21	CHECKED BY DATE A. DHIR 2005/06/21	MX150 RECEPTACLE TERMINAL  <b>molex</b>  DOCUMENT NO. SD-33012-002 SHEET NO. 3 OF 5	
ANGULAR ± 3° DRAFT WHERE APPLICABLE MUST REMAIN WITHIN DIMENSIONS	MATERIAL NO. <b>SEE TABLE</b>	THIS DRAWING CONTAINS INFORMATION THAT IS PROPRIETARY TO MOLEX. INCORPORATED AND SHOULD NOT BE USED WITHOUT WRITTEN PERMISSION					



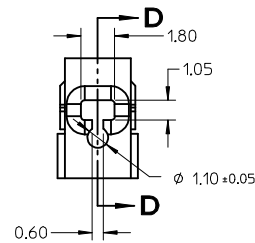
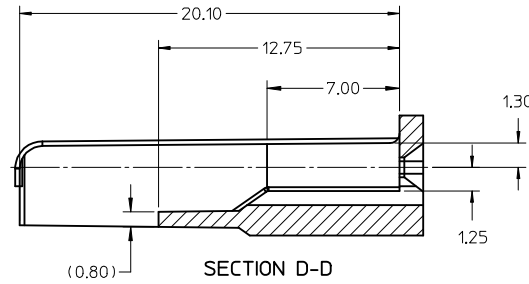
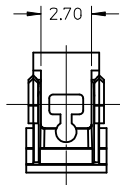

NOTES: UNLESS OTHERWISE SPECIFIED

1. TOLERANCES: LINEAR  $\pm 0.10$   
ANGULAR  $\pm 3^\circ$
2. ALL DRAFT WITHIN TOLERANCE.
3. MAX RADII ON ALL CORNERS SHOWN SHARP: 0.10
4. MAX FLASH PERMISSIBLE: 0.1
5. EJECTOR PIN MARKS PERMISSIBLE IF FLUSH TO 0.25 BELOW SURFACE.
6. MATERIAL: HOUSING/FINGER SPECIFICATION ENGINEERED FOR MATERIAL WITH THE FOLLOWING PROPERTIES:  
A. FLEXURAL MODULUS = 4,500 TO 9,400 MPa  
PER ASTM TEST D790  
B. ELONGATION AT YIELD = 2.3% OR BETTER  
PER ASTM TEST D638 TYPE V
7. CAVITY SPEC FOR USE ONLY WITH MOLEX RECEPTACLE  
TERMINAL PART NUMBERS SPECIFIED ELSEWHERE ON THIS  
DRAWING

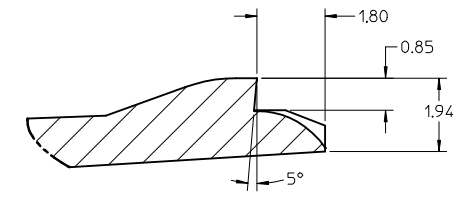
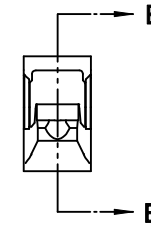
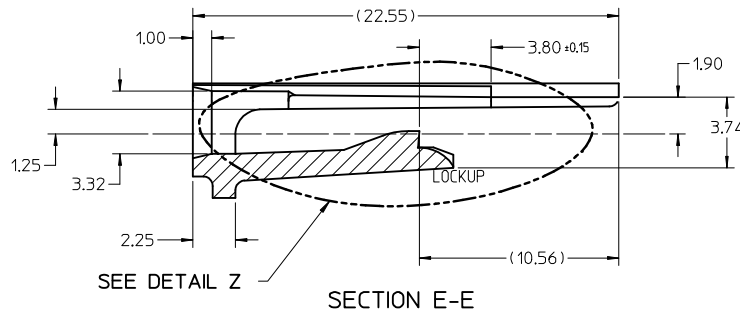
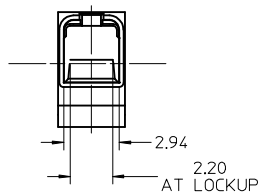

DETAIL Z  
SCALE 20:1

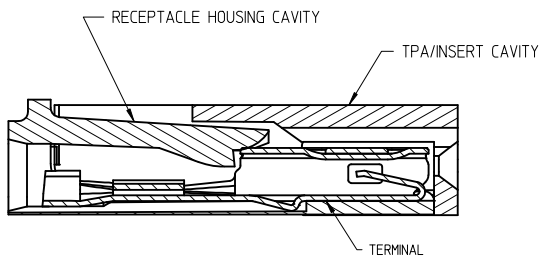

SECTION F-F

RECEPTACLE CAVITY ASSEMBLED VIEWS  
FOR SMALL POLARIZATION RIB APPLICATIONS  
FIG. 1

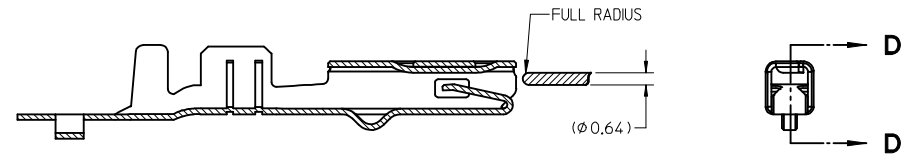
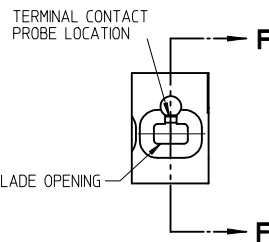

SECTION D-D  
FOR LARGE POLARIZATION RIB APPLICATIONS  
FIG. 2

PROBING DOWN THE  
THROAT MUST USE  
THIS TERMINAL PROBE

FOR PROBING INFORMATION REFERENCE  
MOLEX MX150 APPLICATION SPEC AS-33472-100

PREFERRED PROBING LOCATION  
IS NOT ON SPRING MEMBER

IF ELECTRICAL CONTINUITY PROBE  
TOUCHES SPRING MEMBER USE  
PROBING AS SHOWN IN FIG. 2

ENTER DESCRIPTION EC NO: UAU2017-1076 DRAWN: VENKATESHSH/2017/05/29 CHKD: A. DHIR 2017/05/29 APPR: T.JSMITH 2017/06/09	QUALITY SYMBOLS ▽=0 ▽=0 ▽=0	GENERAL TOLERANCES (UNLESS SPECIFIED)		DIMENSION STYLE <b>MM ONLY</b>	SCALE <b>5:1</b>	DESIGN UNITS <b>METRIC</b>	THIRD ANGLE PROJECTION	
		4 PLACES ± --- ± ---	3 PLACES ± --- ± ---	2 PLACES ± 0.10 ± ---	1 PLACE ± 0.3 ± ---	0 PLACE ± ±	ANGULAR ± 3°	DRAWN BY L. PULLIAM 2005/06/21
C1	DESCRIPTION	DRAFT WHERE APPLICABLE MUST REMAIN WITHIN DIMENSIONS		SIZE C	MATERIAL NO. <b>SEE TABLE</b>	DOCUMENT NO. <b>SD-33012-002</b>	SHEET NO. <b>4 OF 5</b>	
		THIS DRAWING CONTAINS INFORMATION THAT IS PROPRIETARY TO MOLEX INCORPORATED AND SHOULD NOT BE USED WITHOUT WRITTEN PERMISSION						

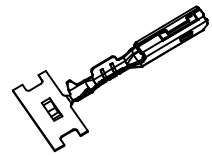

ISO VIEW  
SCALE 2:1

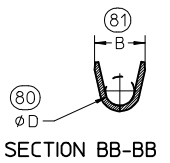
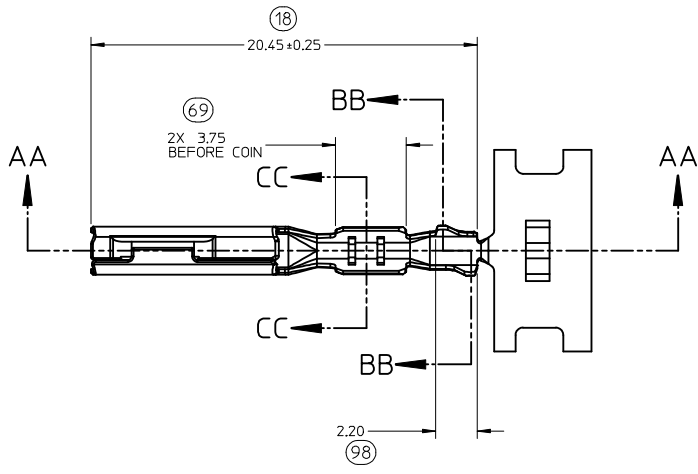

SECTION BB-BB

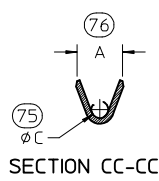

SECTION CC-CC

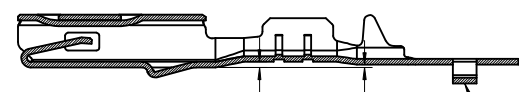
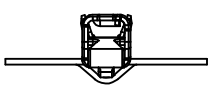

SECTION AA-AA  
**M3 GRIP CODE TERMINAL**  
SEE TABLE (SHEET 2) FOR PART NUMBERS

CARRIER BUMP DIRECTION  
POINTS DOWN FOR TIN PLATED TERMINAL  
POINTS UP FOR PRECIOUS METAL PLATED TERMINAL

ENTER DESCRIPTION EC NO: UAU2017-1076 DRW: N VENKATESH 2017/05/29 CHKD: A. DHIR 2017/05/29 APPR: T. SMITH 2017/06/09	QUALITY SYMBOLS ▽=0 ▽=0 ▽=0	GENERAL TOLERANCES (UNLESS SPECIFIED)		DIMENSION STYLE <b>MM ONLY</b>	SCALE <b>5:1</b>	DESIGN UNITS <b>METRIC</b>	THIRD ANGLE PROJECTION
		4 PLACES ± --- ± ---	DRAWN BY L. PULLIAM	DATE 2005/06/21	TITLE <b>MX150 RECEPTACLE TERMINAL</b>		
		3 PLACES ± --- ± ---	CHECKED BY A. DHIR	DATE 2005/06/21	MOLEX INCORPORATED		
		2 PLACES ± 0.10 ± ---	APPROVED BY B. MOSER	DATE 2005/06/22	MATERIAL NO. <b>SEE TABLE</b>	DOCUMENT NO. <b>SD-33012-002</b>	SHEET NO. <b>5 OF 5</b>
1 PLACE ± 0.3 ± ---	ANGULAR ± 3°	DRAFT WHERE APPLICABLE MUST REMAIN WITHIN DIMENSIONS		THIS DRAWING CONTAINS INFORMATION THAT IS PROPRIETARY TO MOLEX INCORPORATED AND SHOULD NOT BE USED WITHOUT WRITTEN PERMISSION			

TABLE OF CONTENTS	
SHEET NO.	SHEET DESCRIPTION
1	NOTES AND BOM
2	CONFIGURATIONS
3-4	KEY CONFIGURATIONS
5	BLADE SEALED ASSEMBLY
6	SYSTEM PACKAGING
7	BACKSHELL NOTES
8	BACKSHELL
9	BACKSHELL CONFIGURATIONS

NOTES: VALID UNLESS OTHERWISE SPECIFIED

1. GENERAL:
- a. APPLICATION SPECIFICATION SEE: AS-33472-100
- CONTAINS: PRODUCT INTRODUCTION, PRODUCT SUMMARY, CONNECTOR ASSEMBLY, PACKAGING INFORMATION, CONNECTOR MATING, SERVICE INSTRUCTIONS, ELECTRICAL CONTINUITY CHECKING, CRIMPING, AND TROUBLESHOOTING.
  - DESIGNED TO MATE WITH RECEPTACLE SEALED ASSEMBLY AS SPECIFIED IN THE MATING CONNECTOR DRAWINGS CHART.
  - \*DENOTES DRAWINGS THAT CAN BE ACCESSED AT <http://ewcap.uscarteams.org/>
  - ASSEMBLY SHIPPED WITH PLR IN PRE-LOCK POSITION (SEE PLR PRE-LOCK VIEW SHEET 5).
- b. PRODUCT SPECIFICATION SEE:
- STANDARD CONFIGURATION: PS-33471-000
  - UL V0 CONFIGURATION: PS-160105-0001
  - CONTAINS: PRODUCT INTRODUCTION, PRODUCT SUMMARY, RATINGS (CURRENT, TEMPERATURE, SEALING, AND FLAMMABILITY), TERMINALS, WIRE DIAMETER RANGE, PRODUCT VALIDATION, AND PRODUCT DEVIATIONS.
- c. PACKAGING SPECIFICATION PER MOLEX DRAWING: PK-31300-635 (PK-33471-000 FOR 1X5)
- d. PARTS MUST BE IN COMPLIANCE TO MOLEX CHEMICAL SUBSTANCES FOR PRODUCTS AND PACKAGING SPECIFICATION: QEHS-699000-300
- e. DATA MUST BE SUBMITTED UNDER THE MOLEX PART NUMBER TO IMDS (COMPANY ID#13255)
2. DESIGN - MATERIALS:
- a. FOR BILL OF MATERIALS SEE:
- STANDARD CONFIGURATION: SD-33481-0002
  - UL V0 CONFIGURATION: SD-160106-0002
3. DESIGN - GEOMETRY:
- a. THE 3-D CAD DATA IS BASIC (WITHOUT TOLERANCE) AND MASTER FOR THIS PART WITH THE EXCEPTION OF UNDERLINED DIMENSIONS. DIMENSIONAL INFORMATION NOT SHOWN ON THIS DRAWING IS DEFINED BY THE DATA FILE AT ITS LATEST REVISION.
- b. GEOMETRIC DIMENSIONS AND TOLERANCES PER ASME Y14.5M-2009
- c. EDGES AND UNDIMENSIONED DETAILS PER ISO13715
- d. CORNERS SHOWN AS SHARP TO BE R 0.2 MAX.
- e. LETTERING SHALL BE 0.15 MAX RAISED IN 0.25 MAX RECESS PAD. THIS INCLUDES RECYCLING CODE, CAVITY ID, VENDOR IDENTIFICATION, AND CUSTOMER MATERIAL NUMBER.
- f. VISUAL DEFECTS SHALL MEET COSMETIC STANDARD PS-45499-002 (Class B).
- g. LASER MARKING:
1. PART NUMBER
  2. DAY OF THE YEAR
  3. SHIFT
  4. YEAR
- FOR ADDITIONAL INFORMATION SEE SECTION 5 UNDER PROCEDURES IN ES-34735-008.

MATING CONNECTOR DRAWINGS	
DESCRIPTION	MOLEX INLINE
1X2	SD-33471-0001
1X6	SD-33471-0001

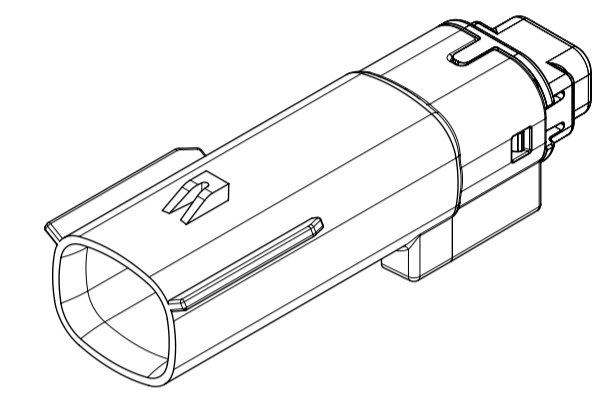

1X2

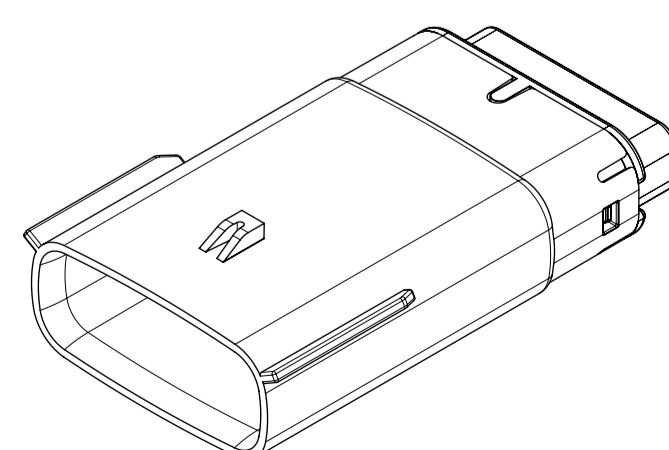
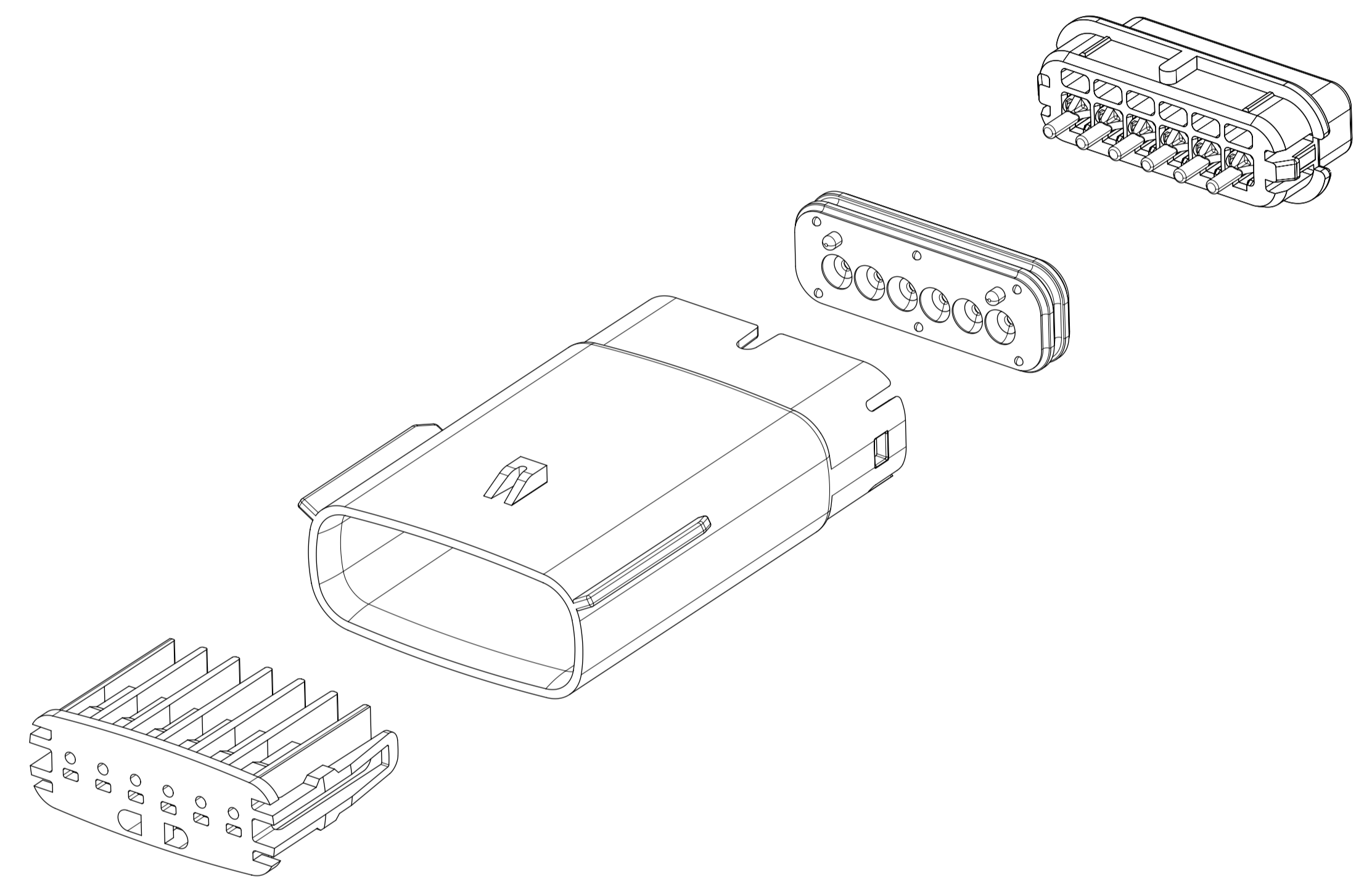

1X6

INSPECTION NUMBER LOG	
LAST NUMBER: 9	ADDED:
REMOVED:	REV
A1	NX REMASTERING , CHANGE PS DRAWING NUMBER FROM PS-160105-0001 TO PS-160074-0001 IN NOTES 1.b
A	MINOR GEOMETRY CHANGE FOR UL V0
2	UPDATED VIEWSETS
1	INITIAL RELEASE
REV	REV DESCRIPTION

<b>SYMBOLS</b> = 0 <b>MM ONLY</b> = 0 <b>GENERAL TOLERANCES (UNLESS SPECIFIED)</b> = 0 <b>ANGULAR TOL ± 1.0°</b> = 0 <b>4 PLACES ±</b> = 0 <b>3 PLACES ±</b> = 0 <b>2 PLACES ± 0.1</b> = 0 <b>1 PLACE ± 0.2</b> = 0 <b>0 PLACES ±</b> = 0 <b>DRAFT WHERE APPLICABLE MUST REMAIN WITHIN DIMENSIONS</b> = 0	THIS DRAWING CONTAINS INFORMATION THAT IS PROPRIETARY TO MOLEX ELECTRONIC TECHNOLOGIES, LLC AND SHOULD NOT BE USED WITHOUT WRITTEN PERMISSION <b>DIMENSION UNITS</b> <b>SCALE</b> <b>1.5:1</b>	<b>CURRENT REV DESC:</b>  EC NO: 602373 DRWN: DSHETTY01 2018/05/25 CHK'D: MVANSLAMBROU 2018/10/04 APPR: MVANSLAMBROU 2018/10/04  <b>INITIAL REVISION:</b> DRWN: APROFFITT 2015/07/21 APPR: KDEKOSKI 2016/06/14	  <b>MX150 BLADE</b> <b>SINGLE ROW SEALED ASSY MAT SEAL</b>	
	<b>PRODUCT CUSTOMER DRAWING</b>			<b>DOCUMENT NUMBER</b> <b>SD-33481-0001</b>
	<b>DRAWING</b> <b>A1-SIZE</b>			<b>DOC TYPE</b> <b>PSD</b>
	<b>SERIES</b> <b>33481</b>			<b>DOC PART</b> <b>001</b>
<b>MATERIAL NUMBER</b> <b>SEE NOTE 2a.</b>		<b>CUSTOMER</b> <b>GENERAL MARKET</b>		
<b>SHEET NUMBER</b> <b>1 OF 9</b>		<b>REVISION</b> <b>A1</b>		

**SHEET DESCRIPTION**  
CONFIGURATIONS

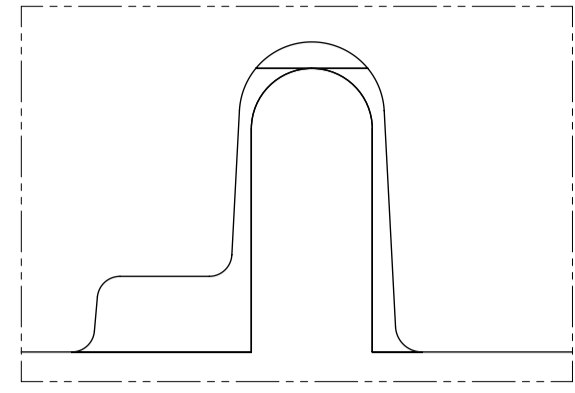

UL V0 UNIQUE FEATURE  
Partial1  
SCALE 10:1

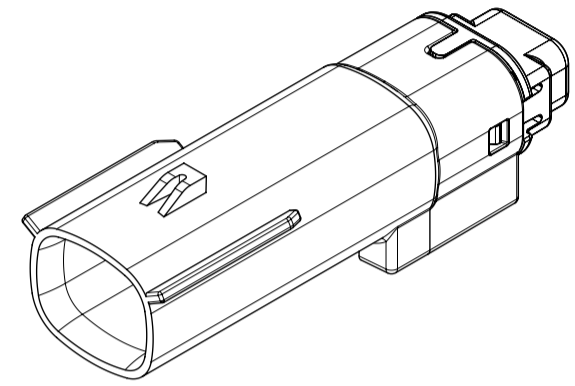

1x2 - STD

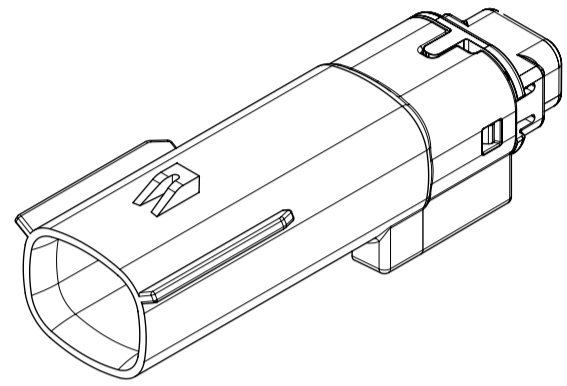

1X2 - UL V0\*

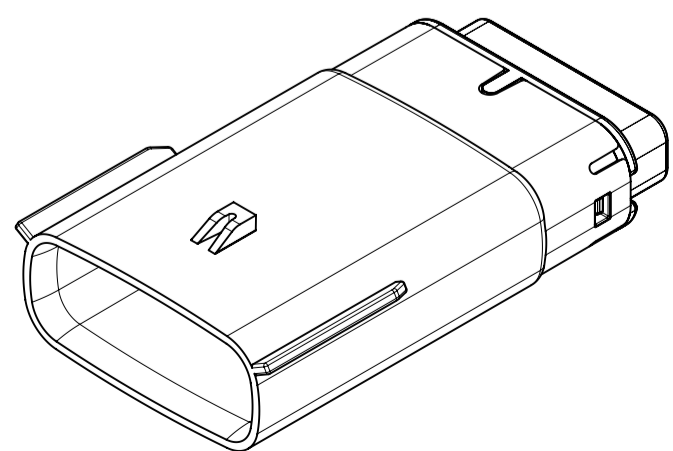

1x6 - STD

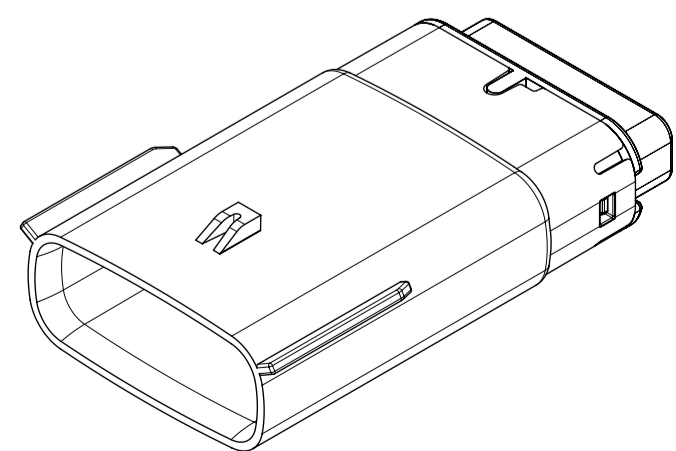

1x6 - UL V0\*

\* MINOR GEOMETRY DIFFERENCE THAN STANDARD CONFIGURATION.  
SEE NOTES 1 & 2 FOR MORE INFORMATION

SYMBOLS	THIS DRAWING CONTAINS INFORMATION THAT IS PROPRIETARY TO MOLEX ELECTRONIC TECHNOLOGIES, LLC AND SHOULD NOT BE USED WITHOUT WRITTEN PERMISSION		CURRENT REV DESC:					
	DIMENSION UNITS	SCALE						EC NO: 602373
▽ = 0	MM ONLY	1.5:1	GENERAL TOLERANCES (UNLESS SPECIFIED)		CHK'D: MVANSLAMBROU	2018/10/04	PRODUCT CUSTOMER DRAWING	
▽ = 0	ANGULAR TOL ± 1.0°		4 PLACES ±		APPR: MVANSLAMBROU	2018/10/04	DOCUMENT NUMBER	
▽ = 0	3 PLACES ±		2 PLACES ± 0.1		INITIAL REVISION:		SD-33481-0001	DOC TYPE
▽ = 0	1 PLACE ± 0.2		0 PLACES ±		DRWN: APROFFITT	2015/07/21	PSD	DOC PART
⊠ = 0	DRAFT WHERE APPLICABLE MUST REMAIN WITHIN DIMENSIONS		THIRD ANGLE PROJECTION		APPR: KDEKOSKI	2016/06/14	001	REVISION
▽ = 0			DRAWING				A1	
			SERIES		MATERIAL NUMBER		CUSTOMER	
			A1-SIZE		33481		SEE NOTE 2a. GENERAL MARKET	
					SHEET NUMBER		2 OF 9	

**SHEET DESCRIPTION**  
KEY CONFIGURATIONS

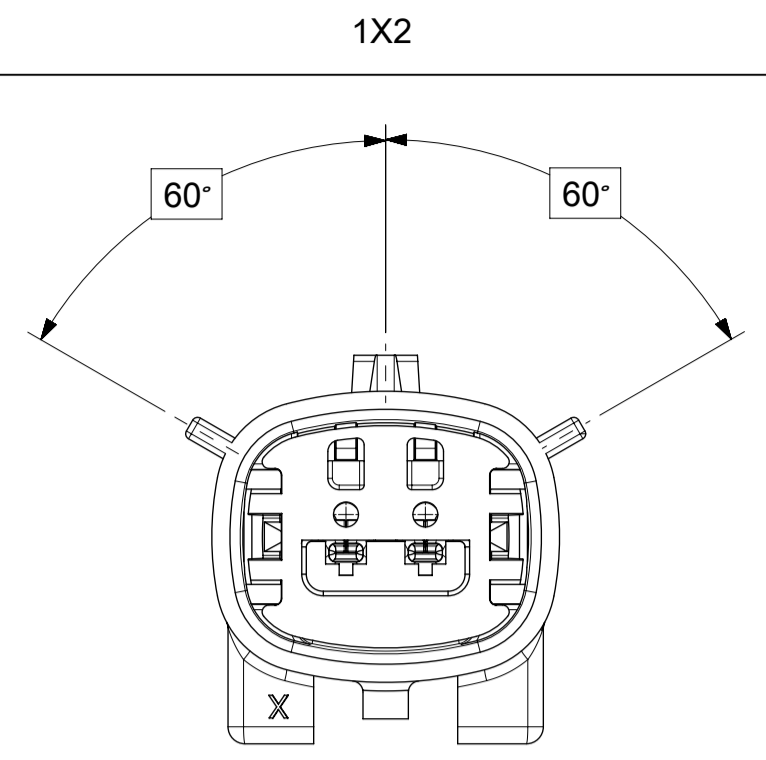

KEY A

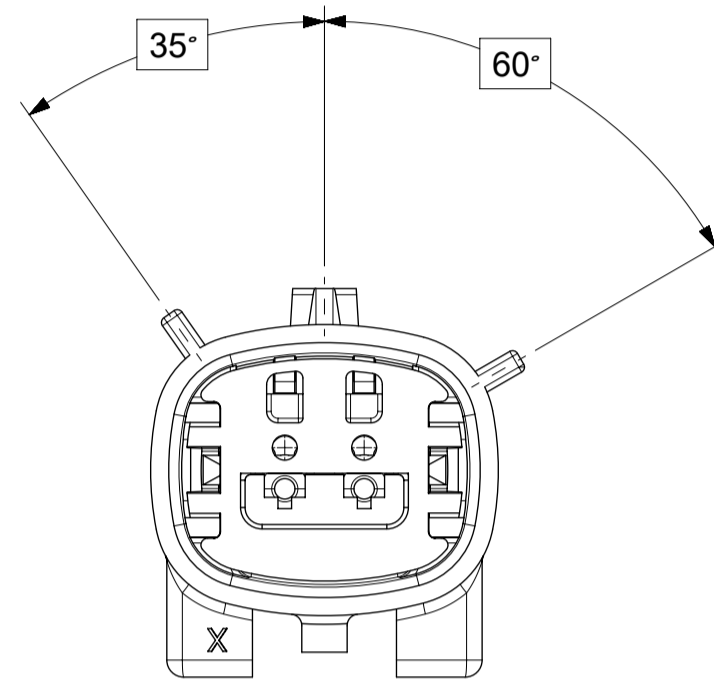

KEY B

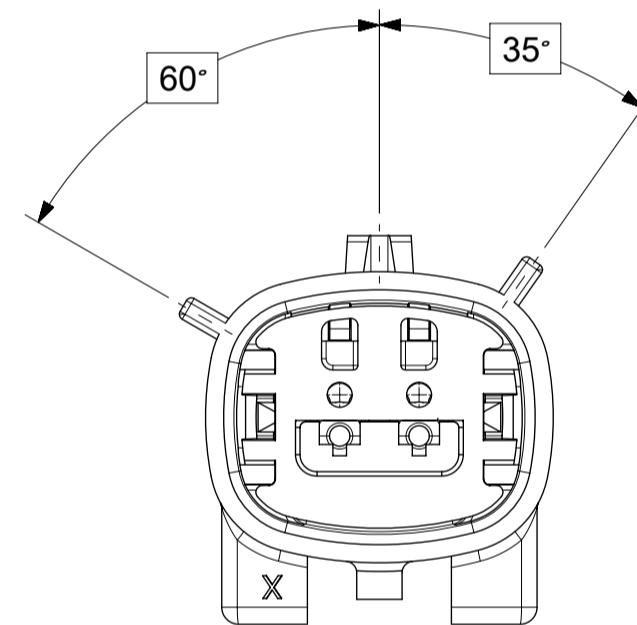

KEY C

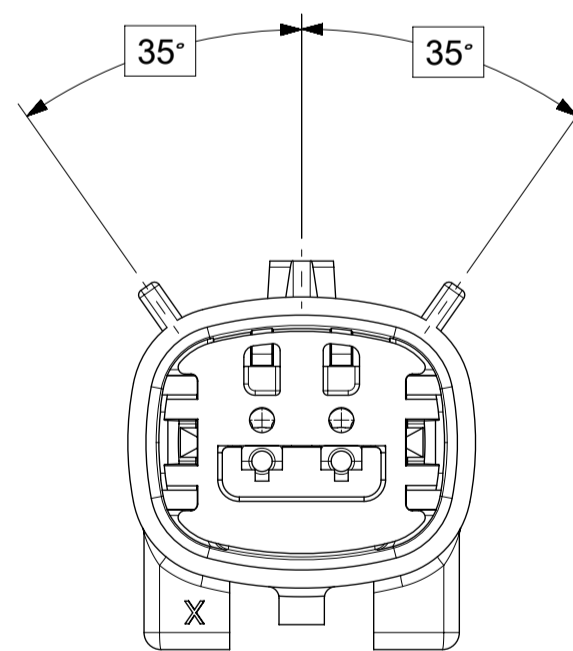

KEY D

<b>SYMBOLS</b> = 0 = 0 = 0 = 0 = 0 = 0 = 0 = 0 = 0 = 0	THIS DRAWING CONTAINS INFORMATION THAT IS PROPRIETARY TO MOLEX ELECTRONIC TECHNOLOGIES, LLC AND SHOULD NOT BE USED WITHOUT WRITTEN PERMISSION		CURRENT REV DESC:		 MX150 BLADE SINGLE ROW SEALED ASSY MAT SEAL			
	DIMENSION UNITS	SCALE	EC NO: 602373					DOCUMENT NUMBER
	MM ONLY	3:1	DRWN: DSHETTY01 2018/05/25		SD-33481-0001	PSD	001	A1
	GENERAL TOLERANCES (UNLESS SPECIFIED)		CHK'D: MVANSLAMBROU 2018/10/04		PRODUCT CUSTOMER DRAWING			
	ANGULAR TOL ± 1.0°		APPR: MVANSLAMBROU 2018/10/04		INITIAL REVISION:			
	4 PLACES ±		DRWN: APROFFITT 2015/07/21		MATERIAL NUMBER			
	3 PLACES ±		APPR: KDEKOSKI 2016/06/14		CUSTOMER			
	2 PLACES ± 0.1		DRAWING		SHEET NUMBER			
	1 PLACE ± 0.2		SERIES		3 OF 9			
	0 PLACES ±		THIRD ANGLE PROJECTION		SEE NOTE 2a. GENERAL MARKET			
DRAFT WHERE APPLICABLE MUST REMAIN WITHIN DIMENSIONS		DRAWING		3 OF 9				

**SHEET DESCRIPTION**  
KEY CONFIGURATIONS CONT.

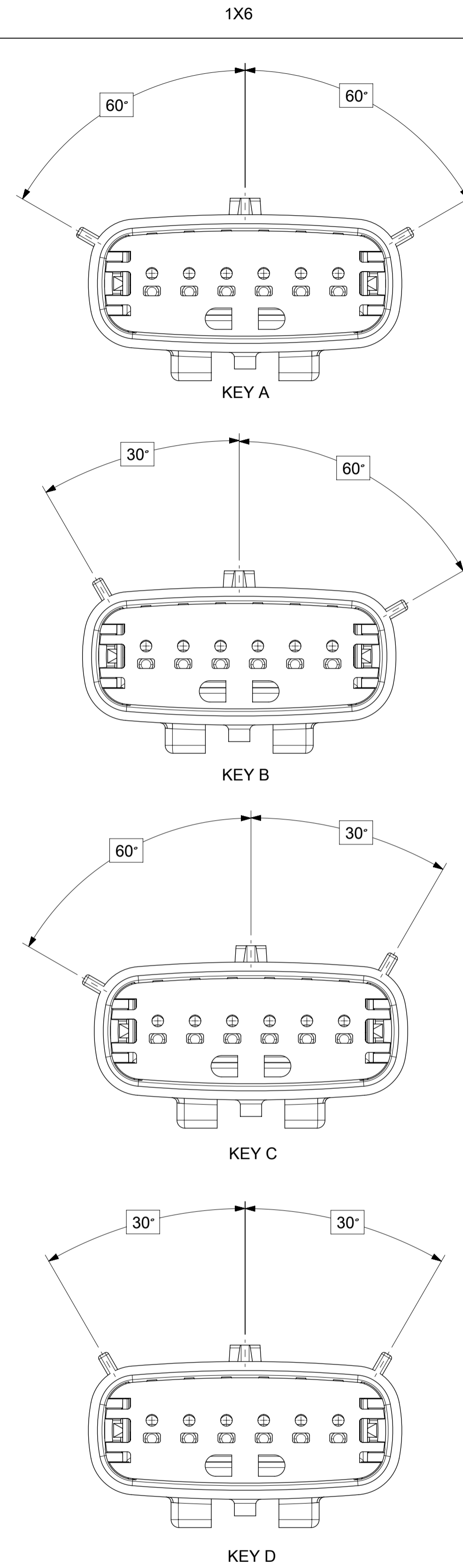

<b>SYMBOLS</b> = 0 = 0 = 0 = 0 = 0 = 0 = 0 = 0	THIS DRAWING CONTAINS INFORMATION THAT IS PROPRIETARY TO MOLEX ELECTRONIC TECHNOLOGIES, LLC AND SHOULD NOT BE USED WITHOUT WRITTEN PERMISSION DIMENSION UNITS: <b>MM ONLY</b> SCALE: <b>3:1</b>	CURRENT REV DESC: EC NO: 602373 DRWN: DSHETTY01 2018/05/25 CHK'D: MVANSLAMBROU 2018/10/04 APPR: MVANSLAMBROU 2018/10/04	 MX150 BLADE SINGLE ROW SEALED ASSY MAT SEAL		
	GENERAL TOLERANCES (UNLESS SPECIFIED) ANGULAR TOL ± 1.0° 4 PLACES ± 3 PLACES ± 2 PLACES ± 0.1 1 PLACE ± 0.2 0 PLACES ±	INITIAL REVISION: DRWN: APROFFITT 2015/07/21 APPR: KDEKOSKI 2016/06/14	PRODUCT CUSTOMER DRAWING DOCUMENT NUMBER: <b>SD-33481-0001</b> DOC TYPE: PSD DOC PART: 001 REVISION: <b>A1</b>	MATERIAL NUMBER: SEE NOTE 2a. CUSTOMER: GENERAL MARKET SHEET NUMBER: 4 OF 9	
DRAFT WHERE APPLICABLE MUST REMAIN WITHIN DIMENSIONS THIRD ANGLE PROJECTION DRAWING: <b>A1-SIZE</b> SERIES: <b>33481</b>					







**SHEET DESCRIPTION**  
BACKSHELL CONFIGURATIONS

CKT	BLADE CONFIGURATION	RECEPTACLE CONFIGURATION	DIMENSIONS				
			M	N	P	R	S
1X2	STANDARD	STANDARD	107.84	29.50	27.00	26.25	25.00

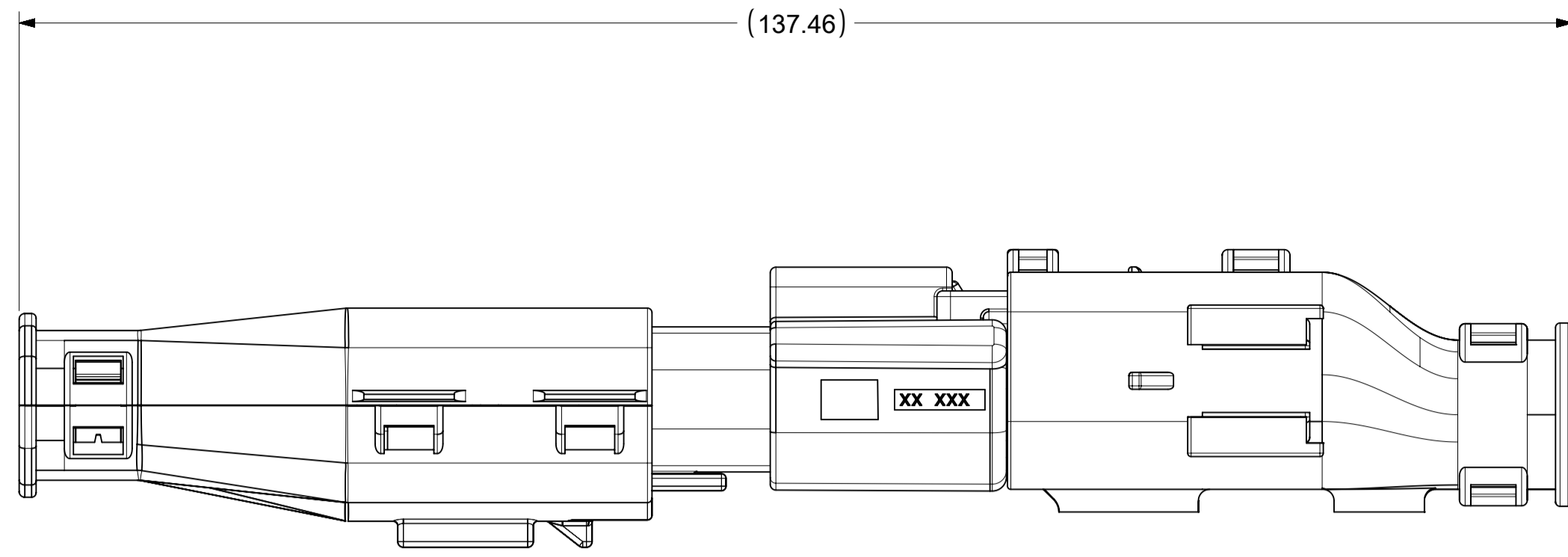

OVERALL MATED SYSTEM WITH BLADE AND RECEPTACLE BACKSHELL

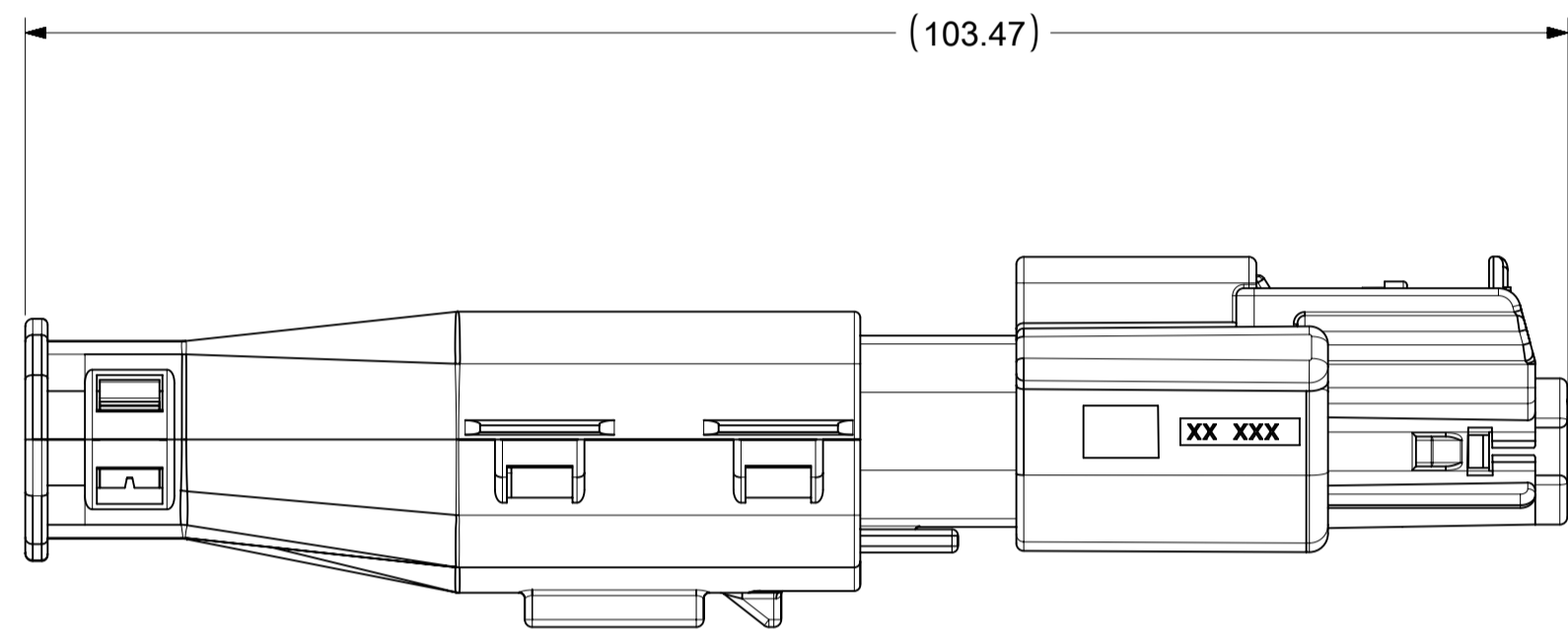
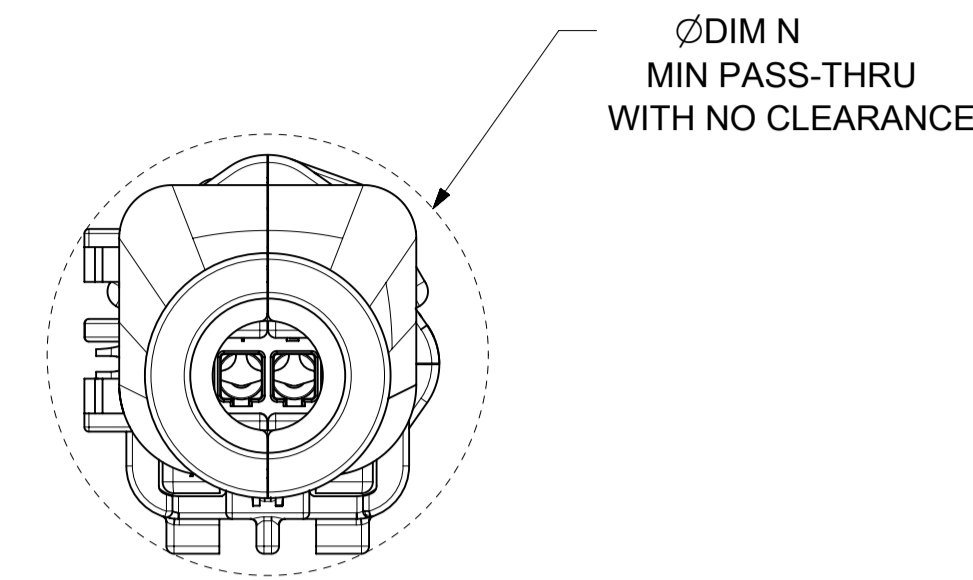

OVERALL MATED SYSTEM WITH BLADE BACKSHELL

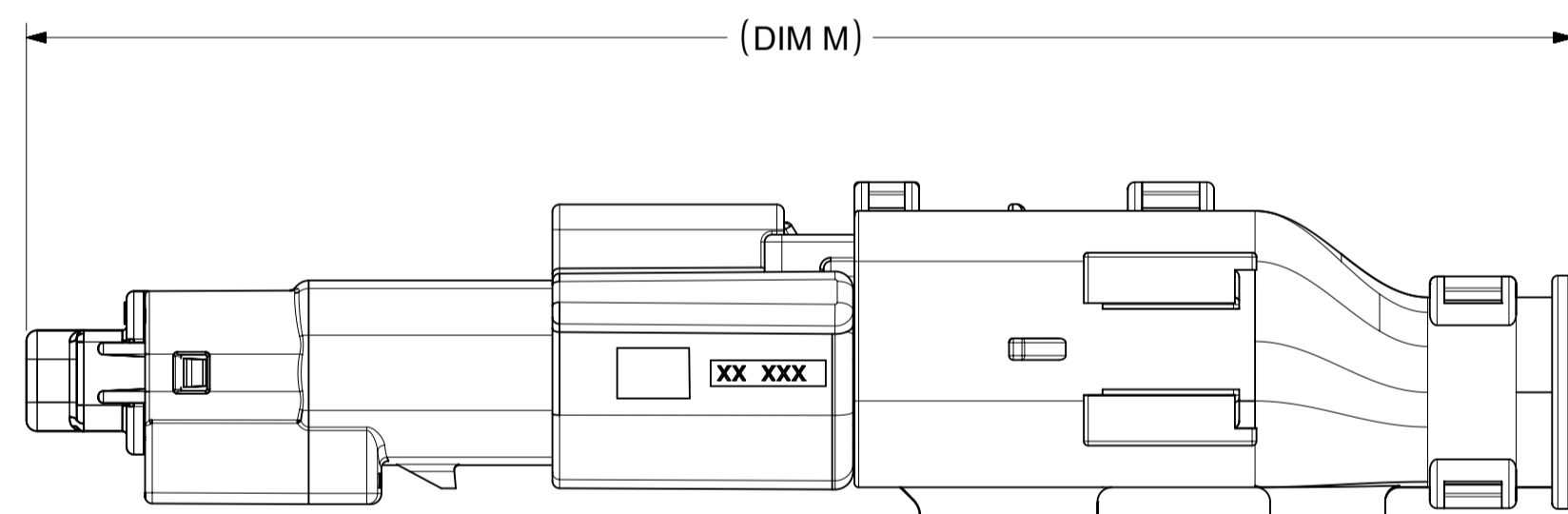
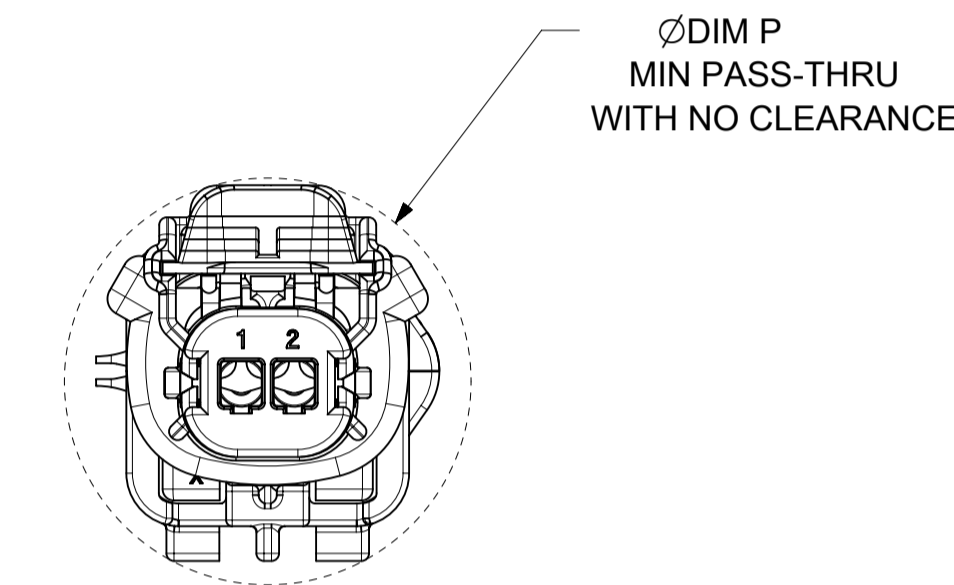

OVERALL MATED SYSTEM WITH RECEPTACLE BACKSHELL

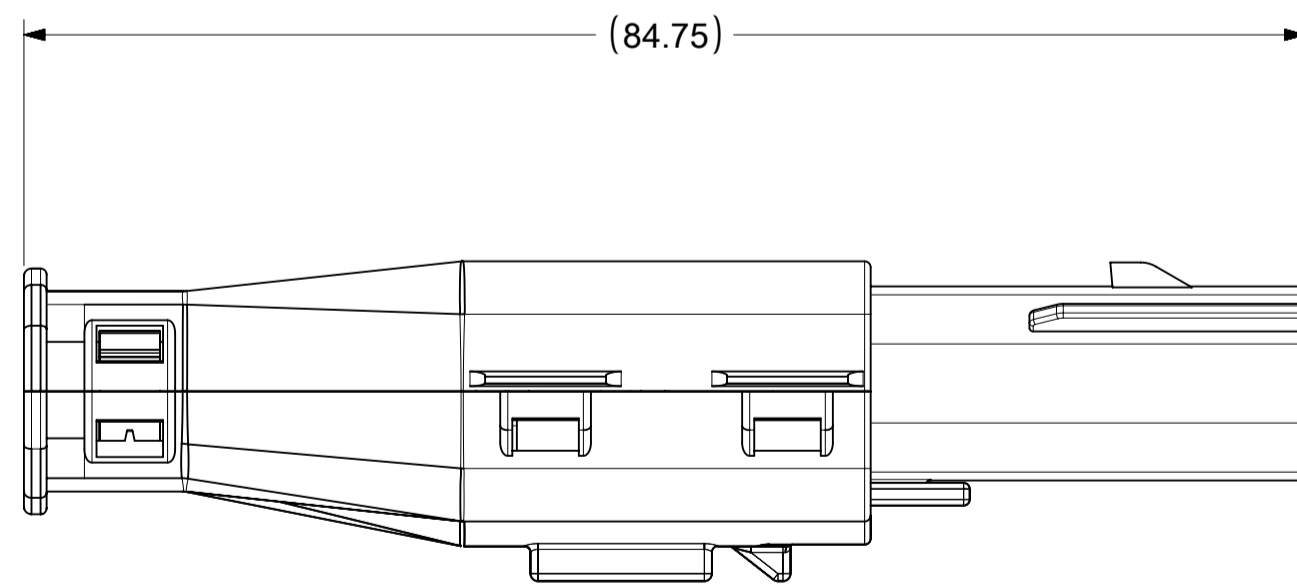
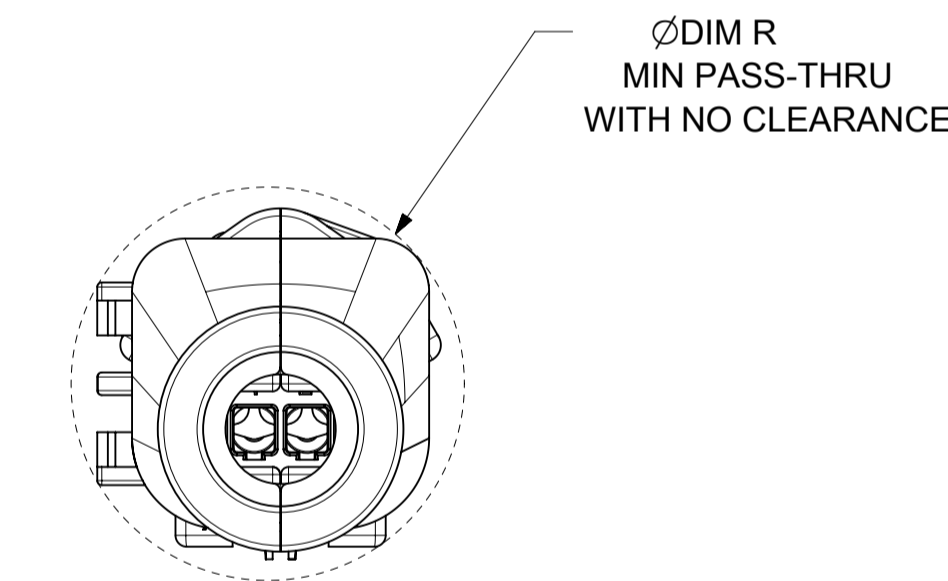

BLADE SEALED ASSEMBLY WITH BLADE BACKSHELL

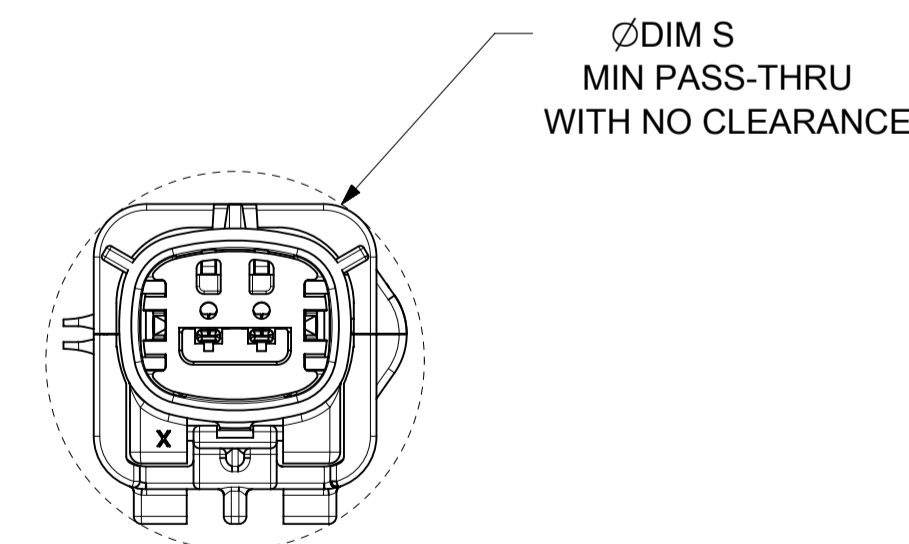

<b>SYMBOLS</b> = 0 	THIS DRAWING CONTAINS INFORMATION THAT IS PROPRIETARY TO MOLEX ELECTRONIC TECHNOLOGIES, LLC AND SHOULD NOT BE USED WITHOUT WRITTEN PERMISSION DIMENSION UNITS: <b>MM ONLY</b> SCALE: <b>2:1</b> GENERAL TOLERANCES (UNLESS SPECIFIED) ANGULAR TOL ± 1.0° 4 PLACES ± 3 PLACES ± 2 PLACES ± 0.1 1 PLACE ± 0.2 0 PLACES ± DRAFT WHERE APPLICABLE MUST REMAIN WITHIN DIMENSIONS	CURRENT REV DESC:  EC NO: 602373 DRWN: DSHETTY01 2018/05/25 CHK'D: MVANSLAMBROU 2018/10/04 APPR: MVANSLAMBROU 2018/10/04  INITIAL REVISION: DRWN: APROFFITT 2015/07/21 APPR: KDEKOSKI 2016/06/14	  MX150 BLADE SINGLE ROW SEALED ASSY MAT SEAL  PRODUCT CUSTOMER DRAWING DOCUMENT NUMBER: <b>SD-33481-0001</b> DOC TYPE: PSD DOC PART: 001 REVISION: <b>A1</b> MATERIAL NUMBER: SEE NOTE 2a. CUSTOMER: GENERAL MARKET SHEET NUMBER: 9 OF 9
--	---	---	---