

NOTES:

1. MATERIALS AND FINISHES:
  - BODY - BERYLLIUM COPPER, GOLD PLATING
  - REAR BODY - BRASS, NICKEL PLATING
  - CONTACT - BERYLLIUM COPPER, GOLD PLATING
  - CAP - BRASS, NICKEL PLATING
  - SPRING RING - BERYLLIUM COPPER, NICKEL PLATING
  - FERRULE - COPPER, NICKEL PLATING
  - INSULATOR - PTFE, NATURAL
2. ELECTRICAL:
  - A. IMPEDANCE: 50 OHM
  - B. FREQUENCY RANGE: DC-6 GHz
  - C. VSWR(RETURN LOSS): 1.14 (-24 dB) MAX. @ DC - 2 GHz  
1.22 (-20 dB) MAX. @ 2 - 4 GHz  
1.38 (-16 dB) MAX. @ 4 - 6 GHz
  - D. DIELECTRIC WITHSTANDING VOLTAGE: 1000 VRMS, MIN.
3. MECHANICAL:
  - A. DURABILITY: 200 CYCLES MIN. FOR SMOOTH BORE  
50 CYCLES MIN. FOR LIMITED DETENT
  - B. TEMPERATURE RANGE: -65°C TO +165°C
4. CABLE ASSEMBLY INSTRUCTIONS:
  - A. TRIM CABLE AS SHOWN.
  - B. SLIDE FERRULE ONTO CABLE.
  - C. INSERT CABLE INTO CONNECTOR.
  - D. SOLDER CONTACT TO CABLE CENTER CONDUCTOR.
  - E. CRIMP FERRULE USING .128" HEX.
  - F. PRESS CAP INTO REAR BODY.
5. SHOWS CABLE ENTRY DIMENSIONS.
6. PACKAGING:
  - A. QUANTITY: SINGLE PACK
  - B. MARKING: PACKAGING TO BE MARKED  
"AMPHENOL RF, 920-513P-51A, AND DATE CODE"

THIRD ANGLE PROJ.

REV		DESCRIPTION	DATE	ECN	APPR
A		RELEASE TO MFG.	13-Sep-19	12923	EH

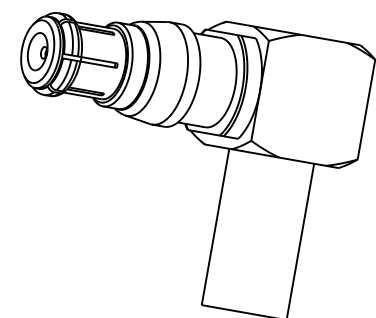
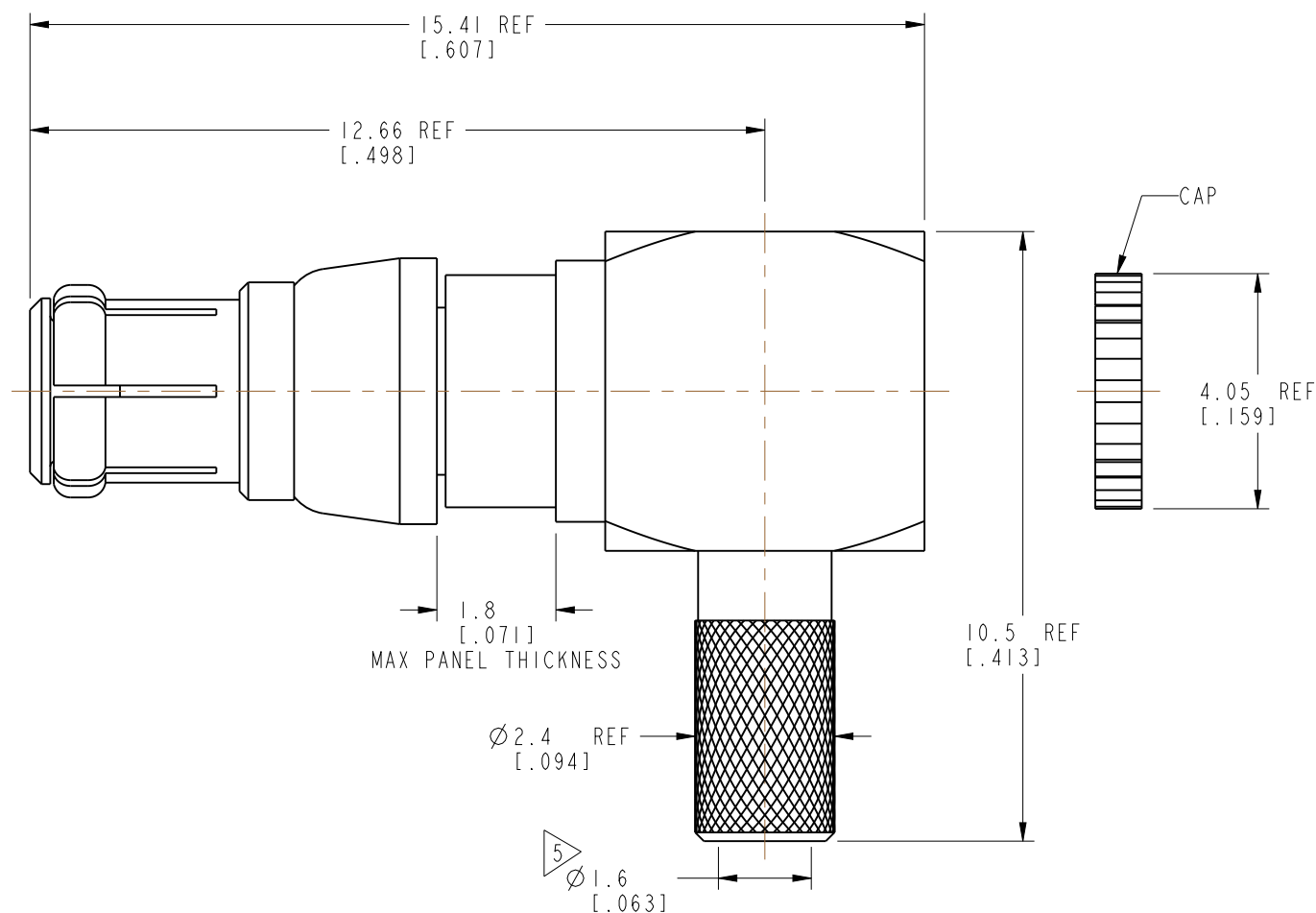

SCALE 3.000

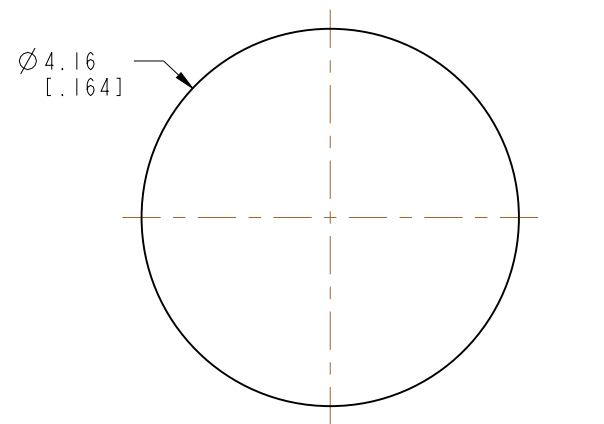

RECOMMENDED PANEL HOLE SIZE

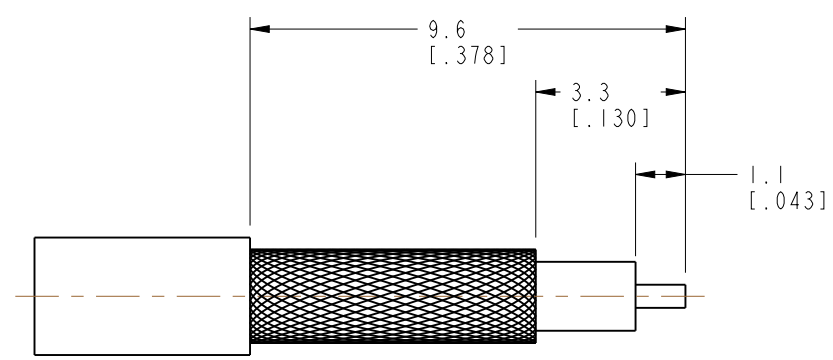

RECOMMENDED CABLE STRIPPING DIMENSIONS

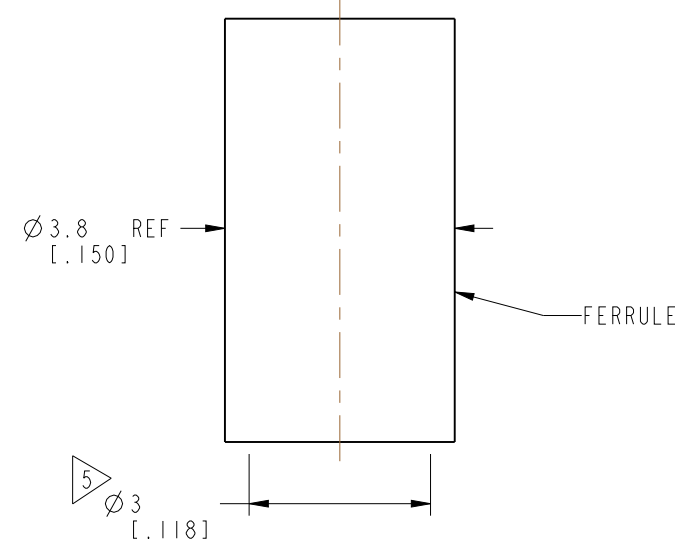

**CUSTOMER OUTLINE DRAWING**  
ALL OTHER SHEETS ARE FOR INTERNAL USE ONLY

UNLESS OTHERWISE SPECIFIED, DIMENSIONS ARE IN METRIC AND TOLERANCES ARE: <0.5mm ± 0.05mm    0.5 - 6mm ± 0.1mm    6 - 30mm ± 0.2mm    30 - 120mm ± 0.3mm    ANGLES ±1°	MATERIAL NOTE 1	DRAWN E. HILL	DATE 11-Jun-19	TITLE R/A HD-EFI PLUG FOR RG-316 CABLE		Amphenol RF www.amphenolrf.com
	REFERENCE EAR# 8405 REF: ---	ENGINEER E. HILL	DATE 11-Jun-19	SCALE: 8.0:1.0 SHEET 2 OF 2		
NOTICE - These drawings, specifications, or other data (1) are, and remain the property of Amphenol corp. (2) must be returned upon request; and (3) are confidential and not to be disclosed to any person other than those to whom they are given by Amphenol Corp. the furnishing of these drawings, specifications, or other data by Amphenol Corp., or to any other person to anyone for any purpose is not to be regarded by implication or otherwise in any manner licensing, granting rights to permitting such holder or any other person to manufacture, use or sell any product, process or design, patented or otherwise, that may in any way be related to or disclosed by said drawings, specifications, or other data.	CONFIGURATION LEVEL: In Work	APPROVED K. CAPOZZI	DATE 13-Sep-19	DWG SIZE B	REV A	ITEM NO. 920-513P-51A
	FINISH	CAD FILE				PART NO. 920-513P-51A