

REVISIONS					
P.	LTN	DESCRIPTION	DATE	DWN	APVD
A		RELEASED PER ECO-19-007456	15MAY2019	CJV	JW
B		REVISED PER ECO-19-011736	06AUG2019	AP	JW

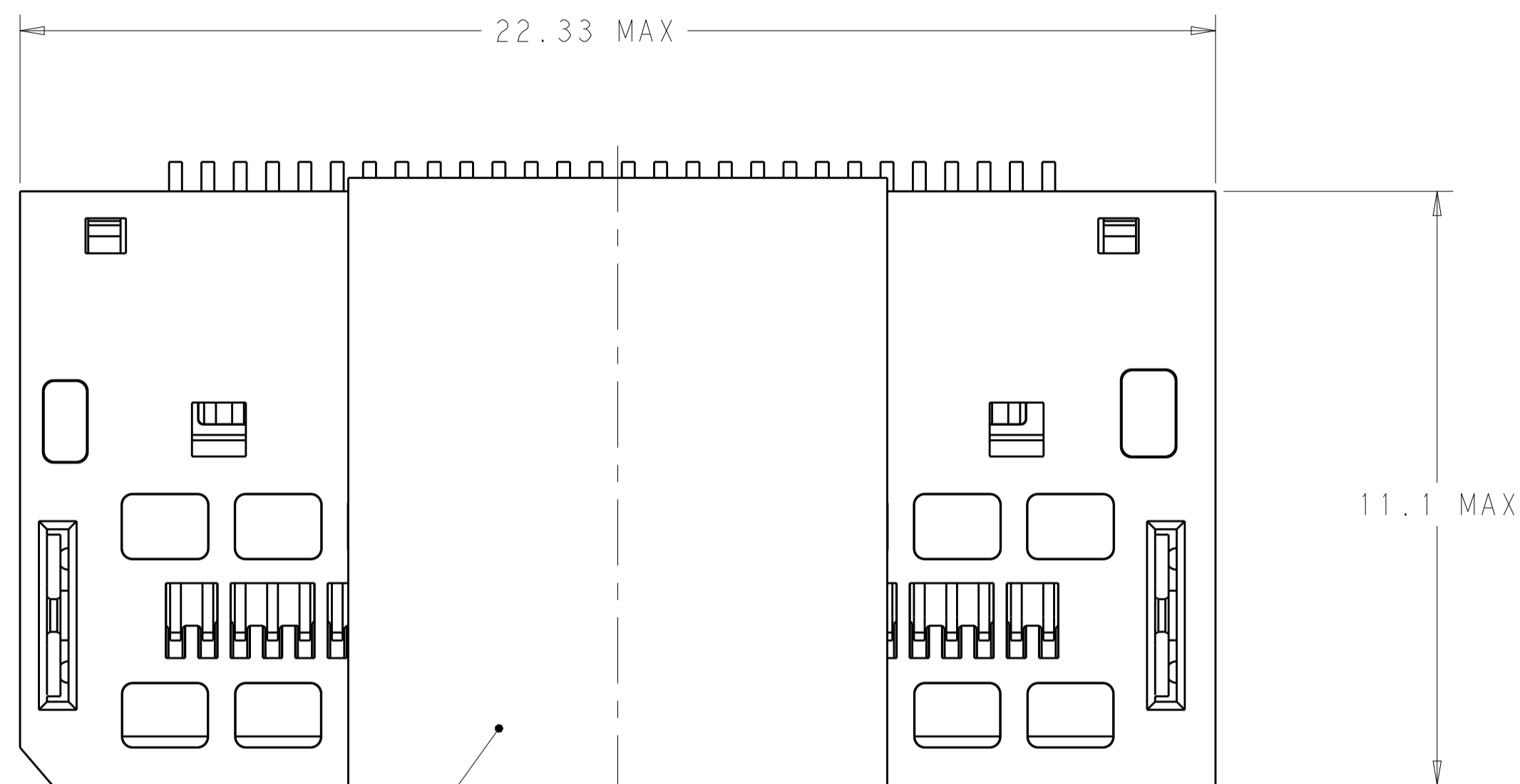

- △ HOUSING, ORGANIZER, CONTACT OVERMOLDS - LCP, UL94-V0, BLACK. CONTACTS AND HOLD DOWNS - COPPER ALLOY. PICK AND PLACE TAPE - POLYIMIDE FILM.
- △ CONTACTS - GOLD PLATE ON MATING SURFACES, TIN PLATE ON SOLDER FEET. HOLD DOWNS - TIN PLATE.
- △ DATUMS AND BASIC DIMENSIONS ESTABLISHED BY CUSTOMER.
- 4. MINIMUM HOST PCB THICKNESS: 1.5.
- △ SEE MSA SPECIFICATION FOR ADDITIONAL PADDLE CARD LAYOUTS COMPATIBLE WITH THIS RECEPTACLE AND FOR OPTIONAL SPLIT CONTACT PAD LAYOUTS FOR THE PADDLE CARD. SPECIFICATION PINOUT MAY ALSO DESIGNATE PAD SEQUENCE DIFFERENT FROM ILLUSTRATION.
- △ POSITIONS DESIGNATED AS "SIGNAL" ARE REQUIRED LOCATIONS FOR HIGH SPEED DIFFERENTIAL PAIR SIGNALING. THESE LOCATIONS MAY ALSO BE USED FOR SUPPORTING SIDEBAND SIGNALS OR OTHER UTILITY PURPOSES. POSITIONS DESIGNATED AS "GROUND" ARE REQUIRED WHEN SUPPORTING HIGH SPEED DIFFERENTIAL SIGNALS. THESE LOCATIONS MAY ALSO BE USED FOR SIDEBAND SIGNALS OR OTHER UTILITY PURPOSES.
- △ COMPONENT AND TRACE KEEP OUT AREA. EACH EDGE 0.15 MIN FROM EDGE OF HOLE.
- △ TAPE AND REEL PACKAGED FOR PICK AND PLACE SMT PROCESSING, SEE FIGURE 1. POCKET TAPE: WIDTH = 44.

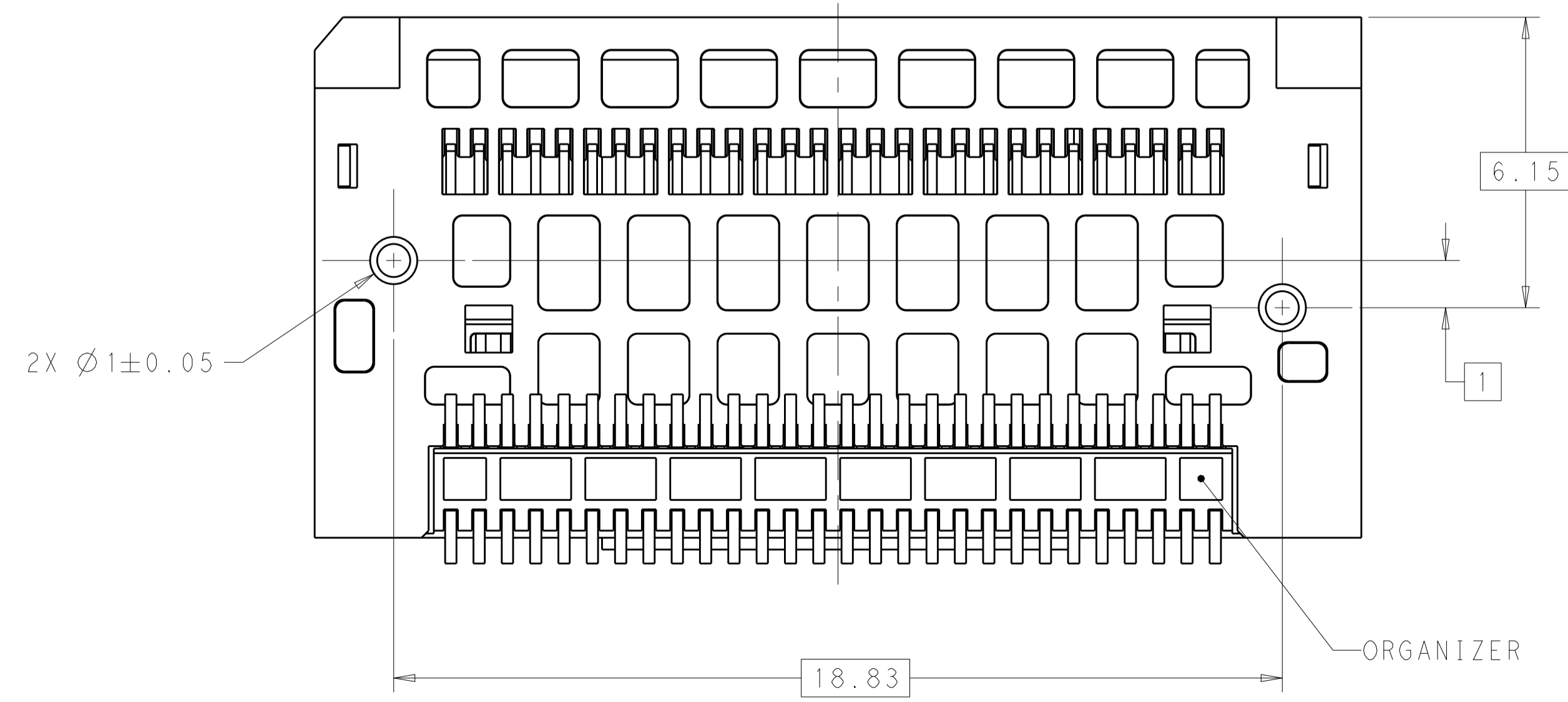
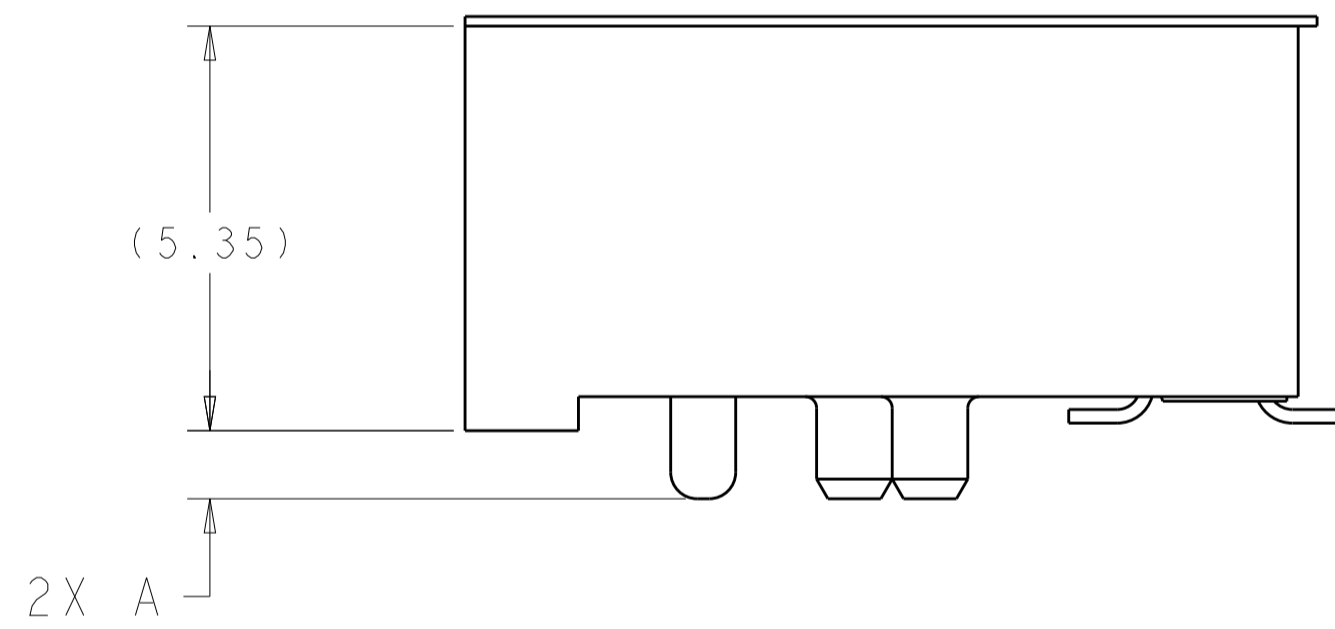
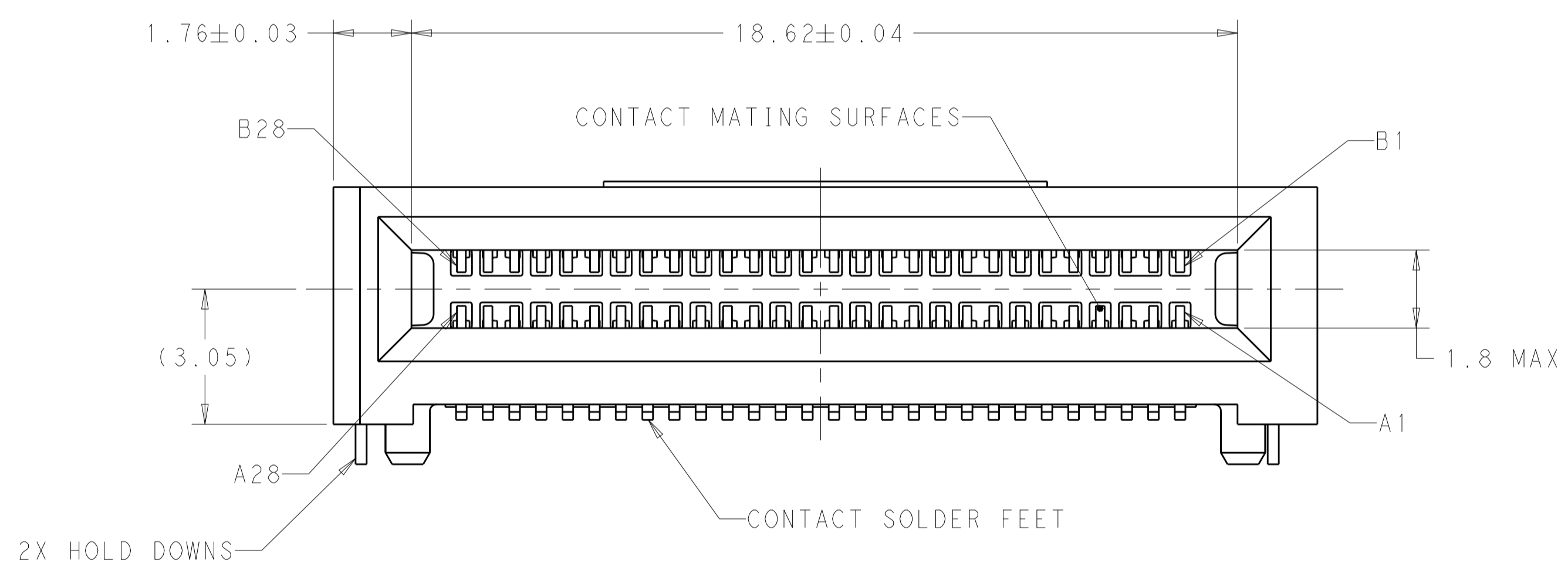

0.9 ± 0.1	0.76 μm Au	24	400	NO	200	1-2327672-3
	0.38 μm Au				100	1-2327672-2
	FLASH Au/PdNi				50	1-2327672-1
	0.76 μm Au				200	2327672-3
	0.38 μm Au				100	2327672-2
A	FLASH Au/PdNi	20	500	YES	50	2327672-1
	PLATING	POCKET TAPE PITCH	REEL QUANTITY	PICK AND PLACE TAPE	MATING CYCLES	PART NUMBER

THIS DRAWING IS A CONTROLLED DOCUMENT.

DIMENSIONS: mm

TOLERANCES UNLESS OTHERWISE SPECIFIED:

0 PLC	±
1 PLC	±
2 PLC	±
3 PLC	±
4 PLC	±
ANGLES	±

MATERIAL: △ FINISH: △

APVD: M. SHIRK 22FEB2018
 CHK: D. HARMON 22FEB2018
 APVD: D. HARMON 22FEB2018

NAME: RECEPTACLE ASSEMBLY, RIGHT ANGLE, 56 POSITION, SLIVER 2.0

SIZE: A1 CAGE CODE: 100779 DRAWING NO: 2327672

RESTRICTED TO: CUSTOMER DRAWING

SCALE: 10:1 SHEET: 1 OF 4 REV: B

REVISIONS				
P.	LTN.	DESCRIPTION	DATE	APVD.
-	-	SEE SHEET 1	-	-

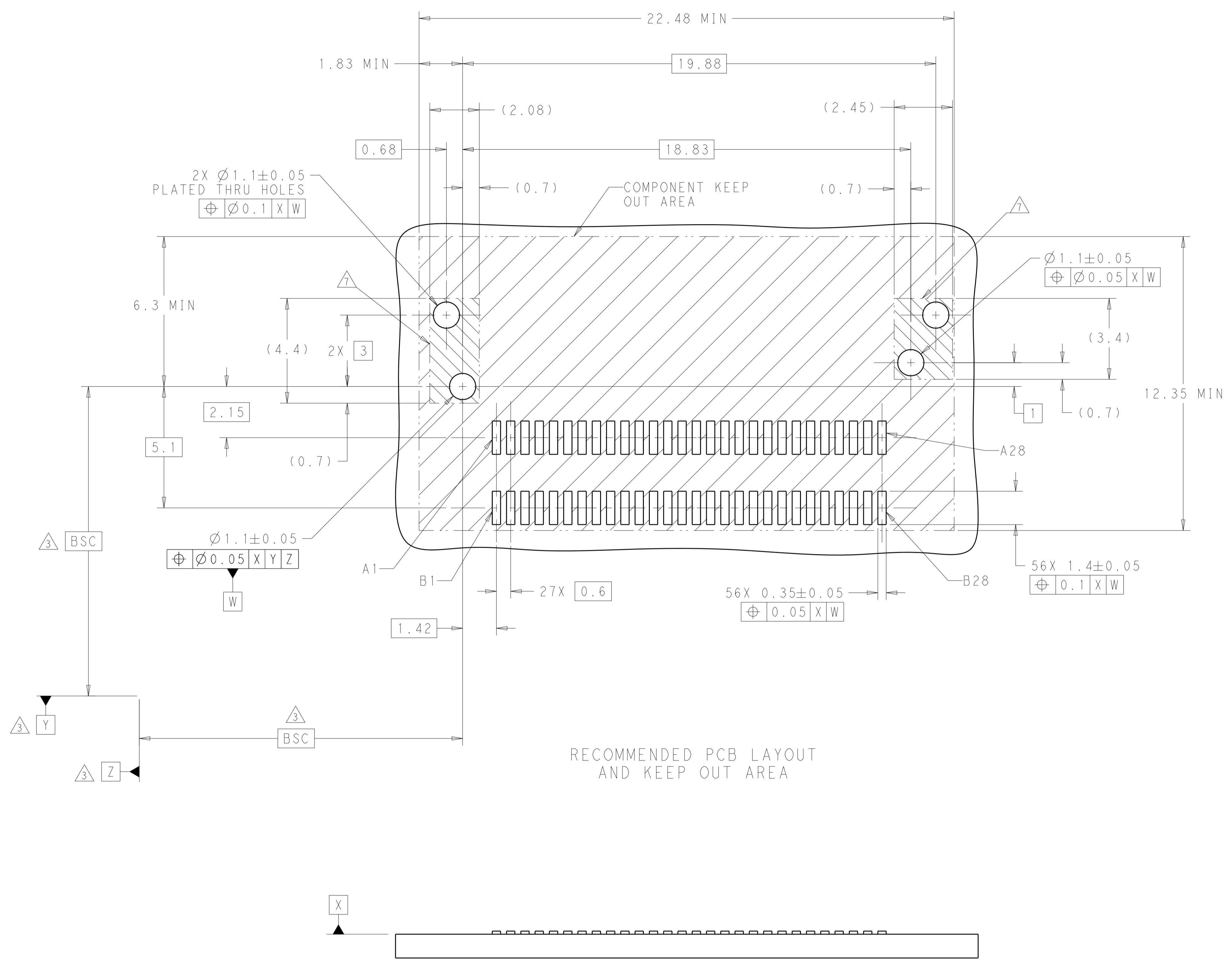

THIS DRAWING IS A CONTROLLED DOCUMENT.		OWN: M. SHIRK 22FEB2018	TE Connectivity
DIMENSIONS: mm		CHK: D. HARMON 22FEB2018	
TOLERANCES UNLESS OTHERWISE SPECIFIED:		APVD: D. HARMON 22FEB2018	NAME: RECEPTACLE ASSEMBLY, RIGHT ANGLE, 56 POSITION, SLIVER 2.0
0 PLC	±	PRODUCT SPEC	108-130021
1 PLC	±	APPLICATION SPEC	114-130008
2 PLC	±	SIZE	A100779
3 PLC	±	CAGE CODE	C=2327672
4 PLC	±	DRAWING NO	2327672
ANGLES	±	RESTRICTED TO	-
MATERIAL	FINISH	WEIGHT	-
CUSTOMER DRAWING		SCALE	10:1
		SHEET	2 OF 4
		REV	B

REVISIONS				
P.	LTN.	DESCRIPTION	DATE	APVD.
-	-	SEE SHEET 1	-	-

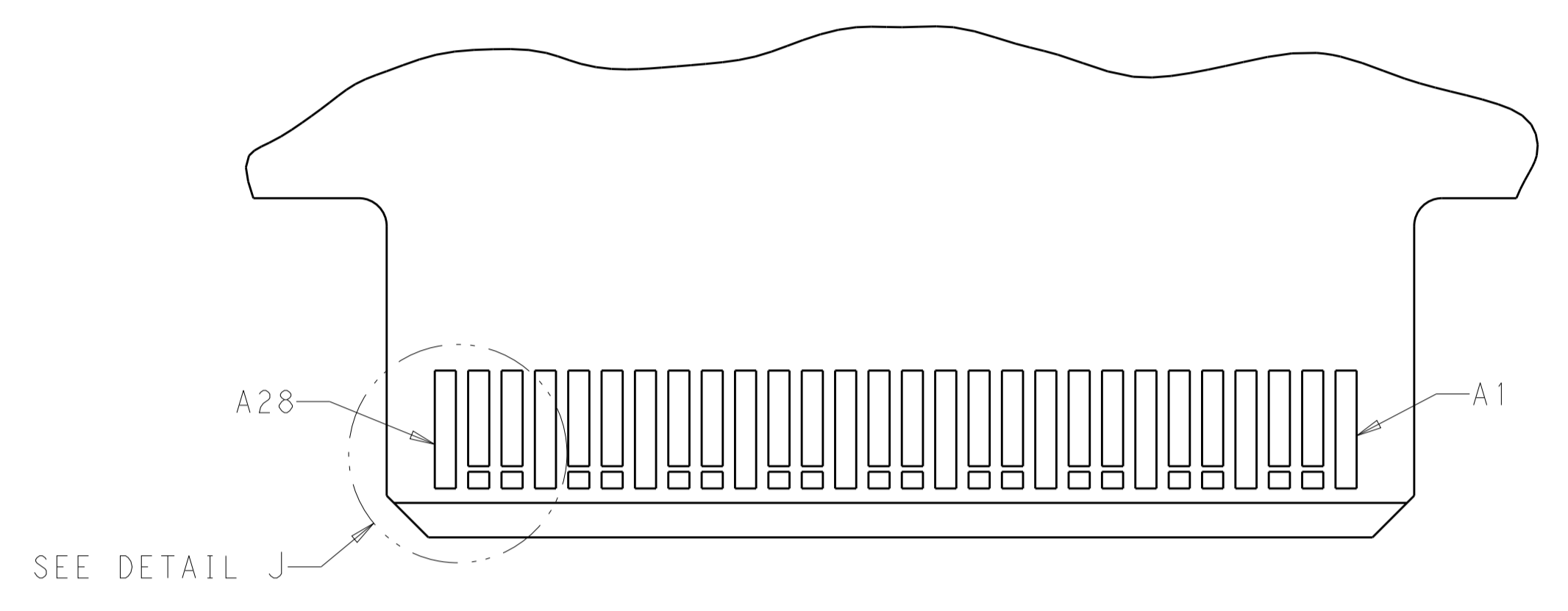
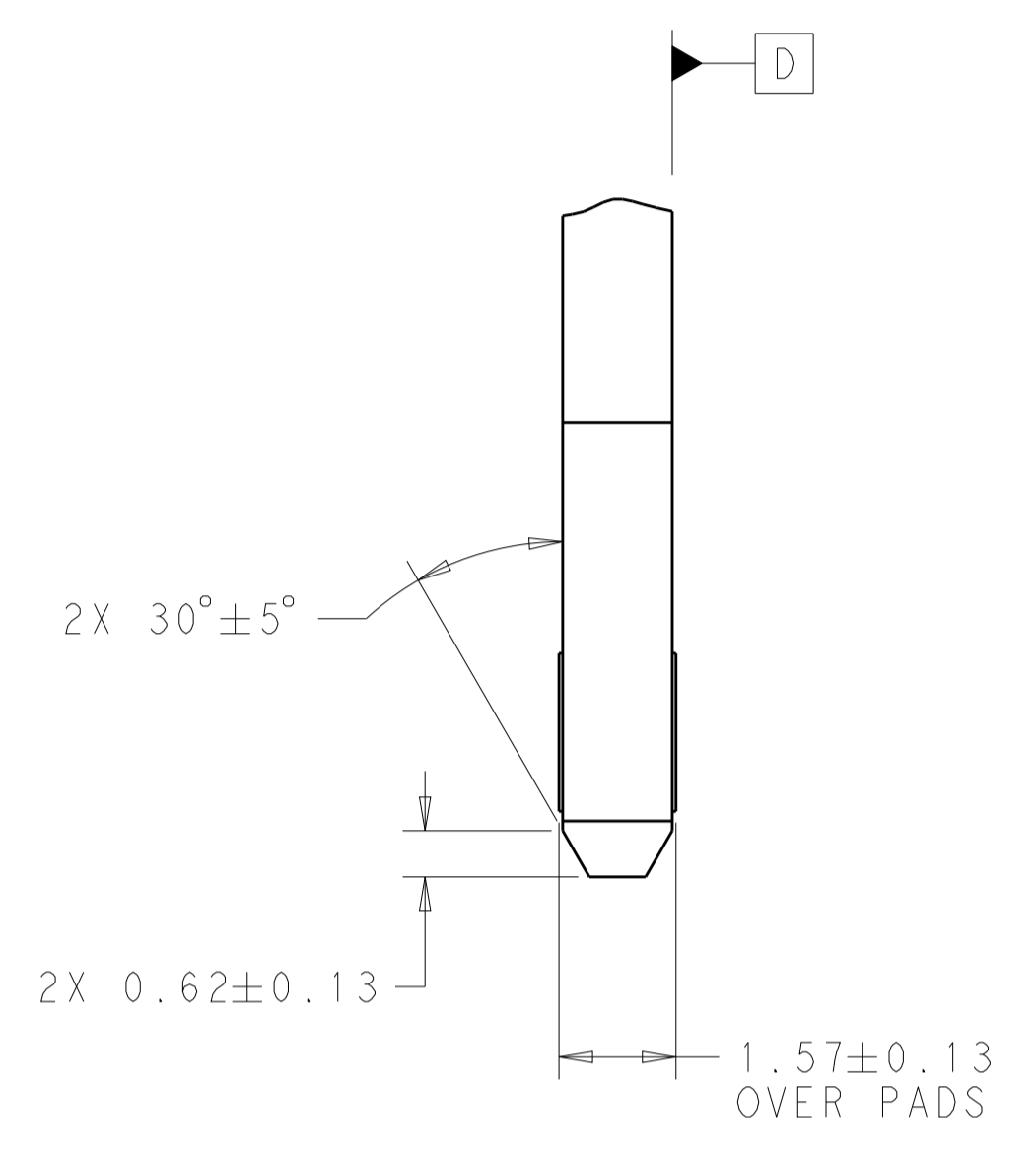
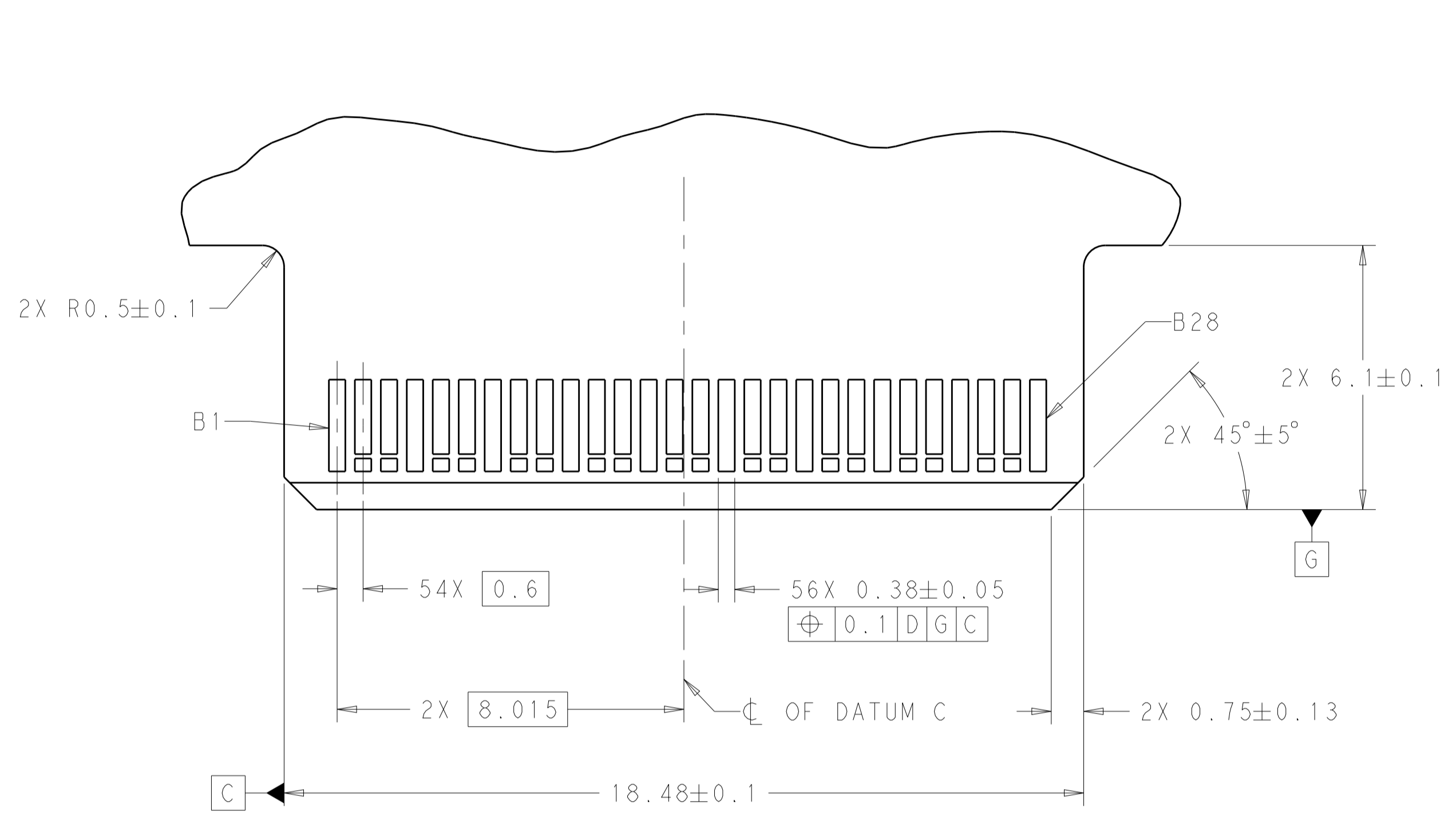

RECOMMENDED PCB OUTLINE DIMENSIONS:
 TOLERANCE VALUES ARE CRITICAL. PLEASE BE SURE TO DESIGNATE
 TOLERANCES TO PCB SUPPLIER TO ENSURE OPTIMIZED FUNCTIONALITY.

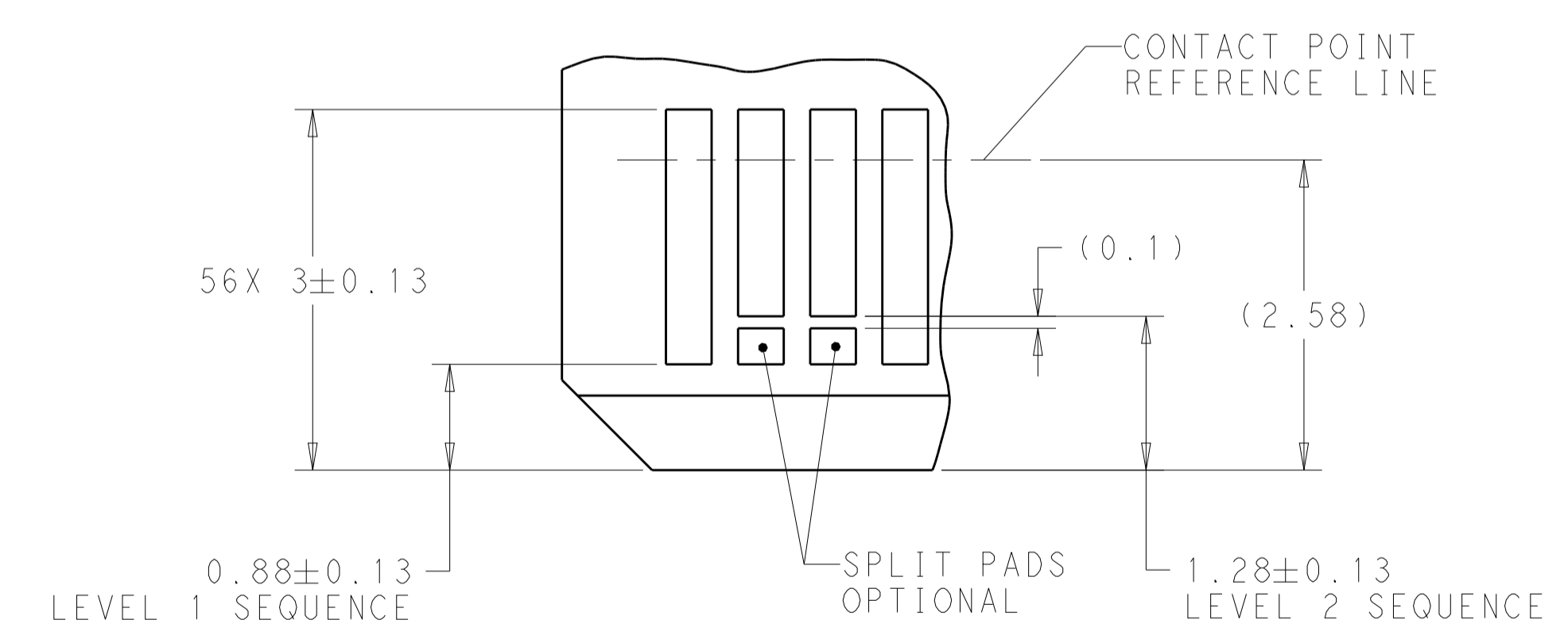

DETAIL J
 SCALE 20:1

THIS DRAWING IS A CONTROLLED DOCUMENT.		OWN M. SHIRK 22FEB2018	TE Connectivity
DIMENSIONS:		CHK D. HARMON 22FEB2018	
mm	TOLERANCES UNLESS OTHERWISE SPECIFIED:	APVD D. HARMON 22FEB2018	NAME RECEPTACLE ASSEMBLY, RIGHT ANGLE, 56 POSITION, SLIVER 2.0
	0 PLC ± 1 PLC ± 2 PLC ± 3 PLC ± 4 PLC ± ANGLES ±	PRODUCT SPEC 108-130021	SIZE A1
MATERIAL	FINISH	APPLICATION SPEC 114-130008	CAGE CODE 2327672
CUSTOMER DRAWING		WEIGHT	RESTRICTED TO
		SCALE 10:1	SHEET 3 OF 4 REV B

REVISIONS				
P.	LTN	DESCRIPTION	DATE	APVD
-	-	SEE SHEET 1	-	-

TABLE 1: CONNECTOR CONTACT IDENTIFICATION 

CONTACT NUMBER	SIDE A	SIDE B
1	GROUND	GROUND
2	SIGNAL	SIGNAL
3	SIGNAL	SIGNAL
4	GROUND	GROUND
5	SIGNAL	SIGNAL
6	SIGNAL	SIGNAL
7	GROUND	GROUND
8	SIGNAL	SIGNAL
9	SIGNAL	SIGNAL
10	GROUND	GROUND
11	SIGNAL	SIGNAL
12	SIGNAL	SIGNAL
13	GROUND	GROUND
14	SIGNAL	SIGNAL
15	SIGNAL	SIGNAL
16	GROUND	GROUND
17	SIGNAL	SIGNAL
18	SIGNAL	SIGNAL
19	GROUND	GROUND
20	SIGNAL	SIGNAL
21	SIGNAL	SIGNAL
22	GROUND	GROUND
23	SIGNAL	SIGNAL
24	SIGNAL	SIGNAL
25	GROUND	GROUND
26	SIGNAL	SIGNAL
27	SIGNAL	SIGNAL
28	GROUND	GROUND

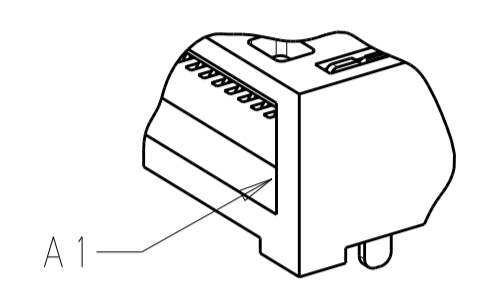

DETAIL B
SCALE 5:1

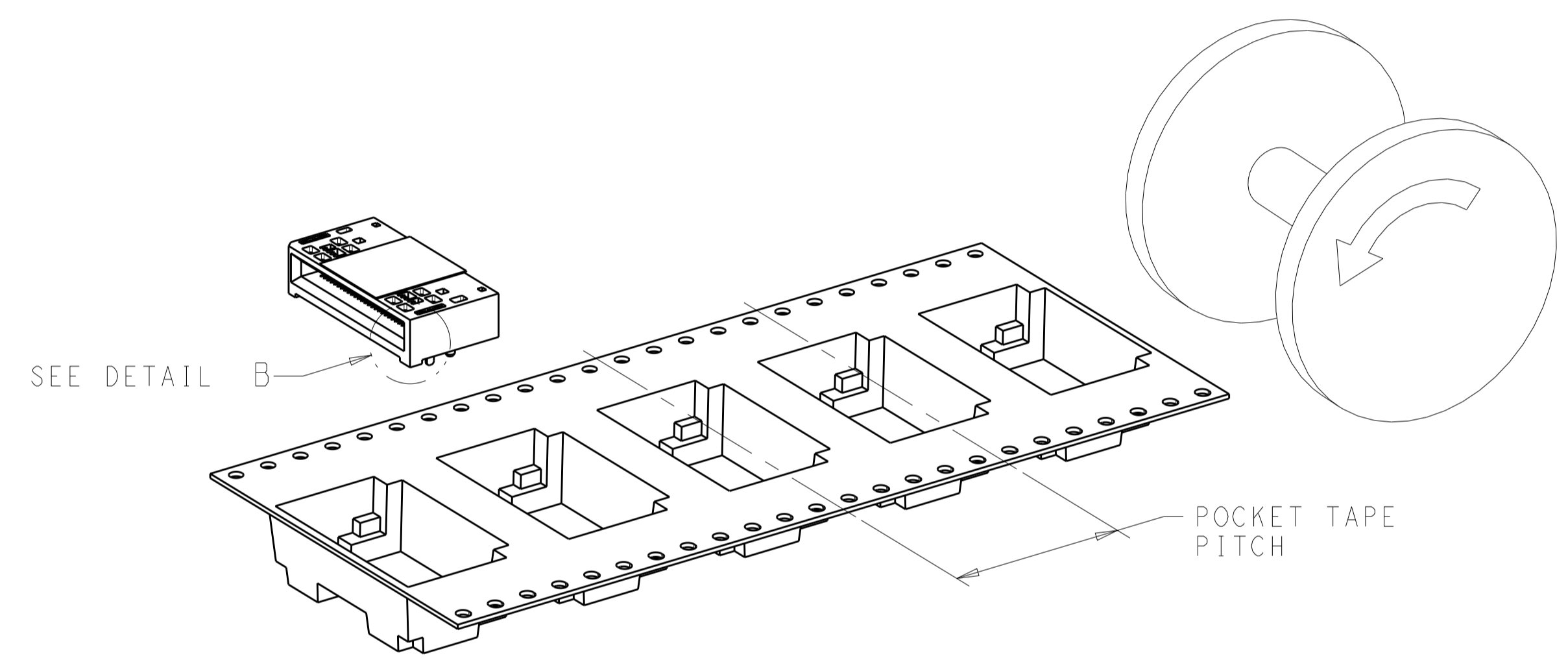

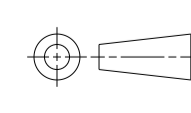

FIGURE 1 
 DIRECTION OFF TOP OF REEL
 FOR USER UNREELING
 SHOWN AS 2327672-1, 2327672-2 OR 2327672-3
 SCALE 2:1

THIS DRAWING IS A CONTROLLED DOCUMENT.		DWN M. SHIRK 22FEB2018 CHK D. HARMON 22FEB2018 APVD D. HARMON 22FEB2018	
DIMENSIONS: mm 	TOLERANCES UNLESS OTHERWISE SPECIFIED: 0 PLC ± 1 PLC ± 2 PLC ± 3 PLC ± 4 PLC ± ANGLES ±	NAME RECEPTACLE ASSEMBLY, RIGHT ANGLE, 56 POSITION, SLIVER 2.0 PRODUCT SPEC 108-130021 APPLICATION SPEC 114-130008 WEIGHT - CUSTOMER DRAWING	
MATERIAL FINISH		SIZE CAGE CODE DRAWING NO A100779C=2327672 SCALE 10:1 SHEET 4 OF 4 REV B	RESTRICTED TO