

THIS DRAWING IS UNPUBLISHED. RELEASED FOR PUBLICATION 20  
 © COPYRIGHT 20 BY - ALL RIGHTS RESERVED.

ITEM	DESCRIPTION	MATERIAL	OTHERS
1	MALE CONTACT	COPPER ALLOY	GOLD PLATED
2	HOUSING	NYLON	BLACK
3	COUPLING NUT	COPPER ALLOY	NICKEL PLATED
4	OVER-MOLDING	TPU/PVC	BLACK
5	SHIELDED SHELL	COPPER ALLOY	NICKEL PLATED
6	CABLE	-	-
7	LABEL	-	-

REVISIONS					
P	LTR	DESCRIPTION	DATE	DWN	APVD
	A	INITIAL RELEASE	18JUL2019	A.Z	C.W
	A1	CORRECT DRAFT ERROR	16OCT2019	A.Z	C.W

NOTE:  
 ①. STRIP AND RETAIN THE INSULATION  
 ②. CODE POSITION INDICATOR  
 ③. RECOMMENDED TORQUE 0.6 Nm  
 ④. -\*\* : CABLE LENGTH, FOR EXAMPLE: -0.5M  
 5. CABLE ASSEMBLY TO BE PACKAGED IN POLYBAGS  
 ⑥. LABEL CONTAINS: PN, DATE CODE...

注释:  
 ①. 剥线并保留护套绝缘层  
 ②. CODE位置指示  
 ③. 推荐扭矩0.6 Nm  
 ④. -\*\* : 线缆长度, 例如: -0.5M  
 5. 线缆组件塑料袋包装  
 ⑥. 标签包含: 产品编号, 日期代码...

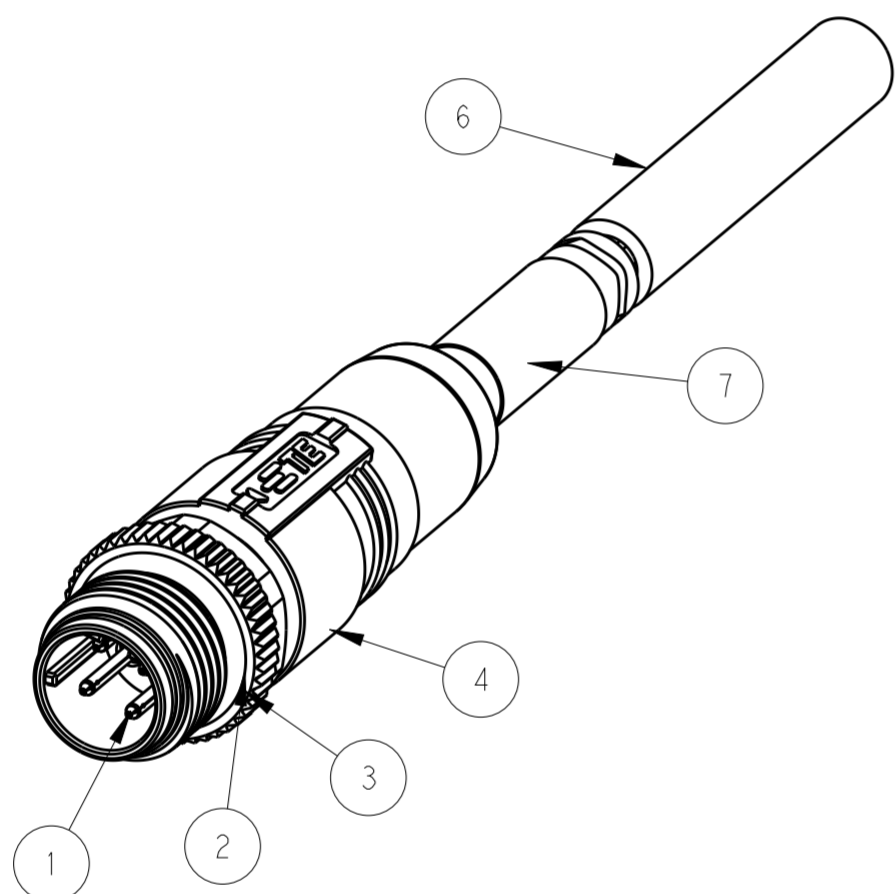
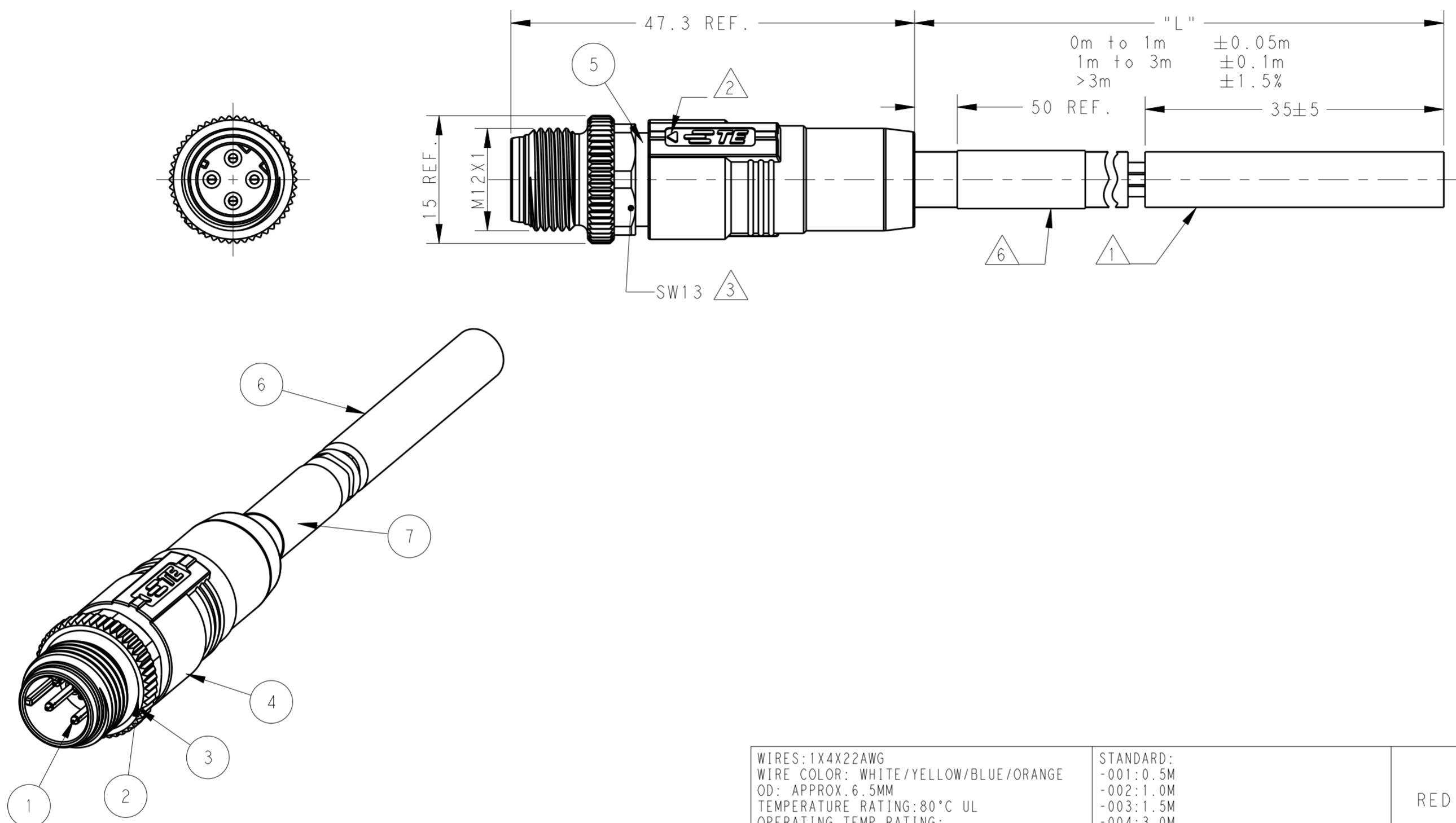

PIN ARRANGEMENT  
D-CODE

PIN 1	TD+	YELLOW
PIN 3	TD-	ORANGE
PIN 2	RD+	WHITE
PIN 4	RD-	BLUE

CIRCUIT DIAGRAM  
MALE

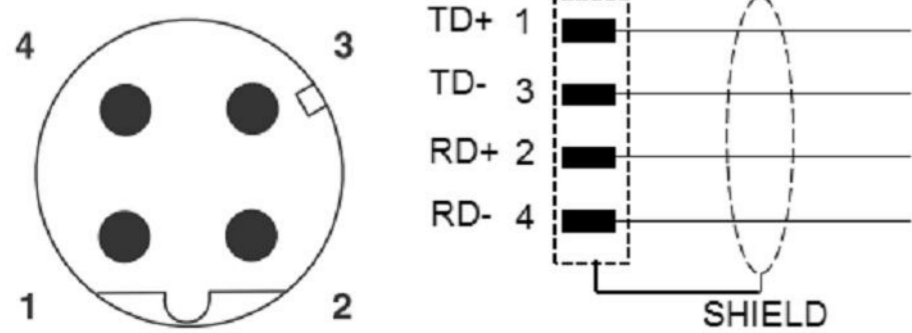

WIRES: 1X4X22AWG WIRE COLOR: WHITE/YELLOW/BLUE/ORANGE OD: APPROX. 6.5MM TEMPERATURE RATING: 80°C UL OPERATING TEMP RATING: -40°C To +80°C	STANDARD: -001: 0.5M -002: 1.0M -003: 1.5M -004: 3.0M -005: 5.0M -006: 7.0M -007: 10.0M CUSTOMIZATION: -99X: 0.XM(<1.0M) (-993: 0.3M) -XXX: XX.XM(>1.0M) (-155: 15.5M)	RED	PVC	M12D4-MS-PVC TYPE B RED-**④	4	TAD14141311-XXX
WIRES: 1X4X22AWG WIRE COLOR: WHITE/YELLOW/BLUE/ORANGE OD: APPROX. 6.65MM TEMPERATURE RATING: 80°C UL OPERATING TEMP RATING: -30°C To +70°C		GREEN	PUR	M12D4-MS-PUR TYPE C GREEN-**④	4	TAD14145101-XXX
WIRES: 1X4X22AWG WIRE COLOR: WHITE/YELLOW/BLUE/ORANGE OD: APPROX. 6.5MM TEMPERATURE RATING: 80°C UL OPERATING TEMP RATING: -25°C To +80°C		GREEN	FRNC	M12D4-MS-FRNC TYPE B GREEN-**④	4	TAD14147101-XXX
WIRES: 1X4X22AWG WIRE COLOR: WHITE/YELLOW/BLUE/ORANGE OD: APPROX. 6.5MM TEMPERATURE RATING: 80°C UL OPERATING TEMP RATING: -40°C To +80°C		GREEN	PVC	M12D4-MS-PVC TYPE B GREEN-**④	4	TAD14141111-XXX
CABLE CHARACTERISTIC	LENGTH "L"	JACKET COLOR	JACKET MATERIAL	TYPE	POS.	TE PN

THIS DRAWING IS A CONTROLLED DOCUMENT.

DIMENSIONS:		TOLERANCES UNLESS OTHERWISE SPECIFIED:	
mm	mm	0 PLC	±
		1 PLC	±
		2 PLC	±
		3 PLC	±
		4 PLC	±
		ANGLES	±
		FINISH	-
MATERIAL	-		-
			-

DWN	ALEX ZHANG	11APR2019	 TE Connectivity
CHK	HART HE	11APR2019	
APVD	CHRIS WANG	11APR2019	
NAME	M12 D CODE CABLE ASSY, SHIELDED 4P, MS FREE END		
PRODUCT SPEC	108-106140		RESTRICTED TO
APPLICATION SPEC	-		SIZE
WEIGHT	-		A2
RESTRICTED CUSTOMER	SCALE 2:1		SHEET 1 OF 2
	REV A1		

THIS DRAWING IS UNPUBLISHED. RELEASED FOR PUBLICATION 20  
 © COPYRIGHT 20 BY - ALL RIGHTS RESERVED.

REVISIONS				
P	LTR	DESCRIPTION	DATE	APVD
-		SEE SHEET 1	-	-

TECHNICAL DATA	
RATED VOLTAGE	250V 30V(UL)
RATED CURRENT	4A 1.5A(UL)
POLLUTION DEGREE	3
OVERVOLTAGE CATEGORY	II
MATERIAL GROUP	II
DEGREE OF PROTECTION	IP67

**TE PN CODING:**

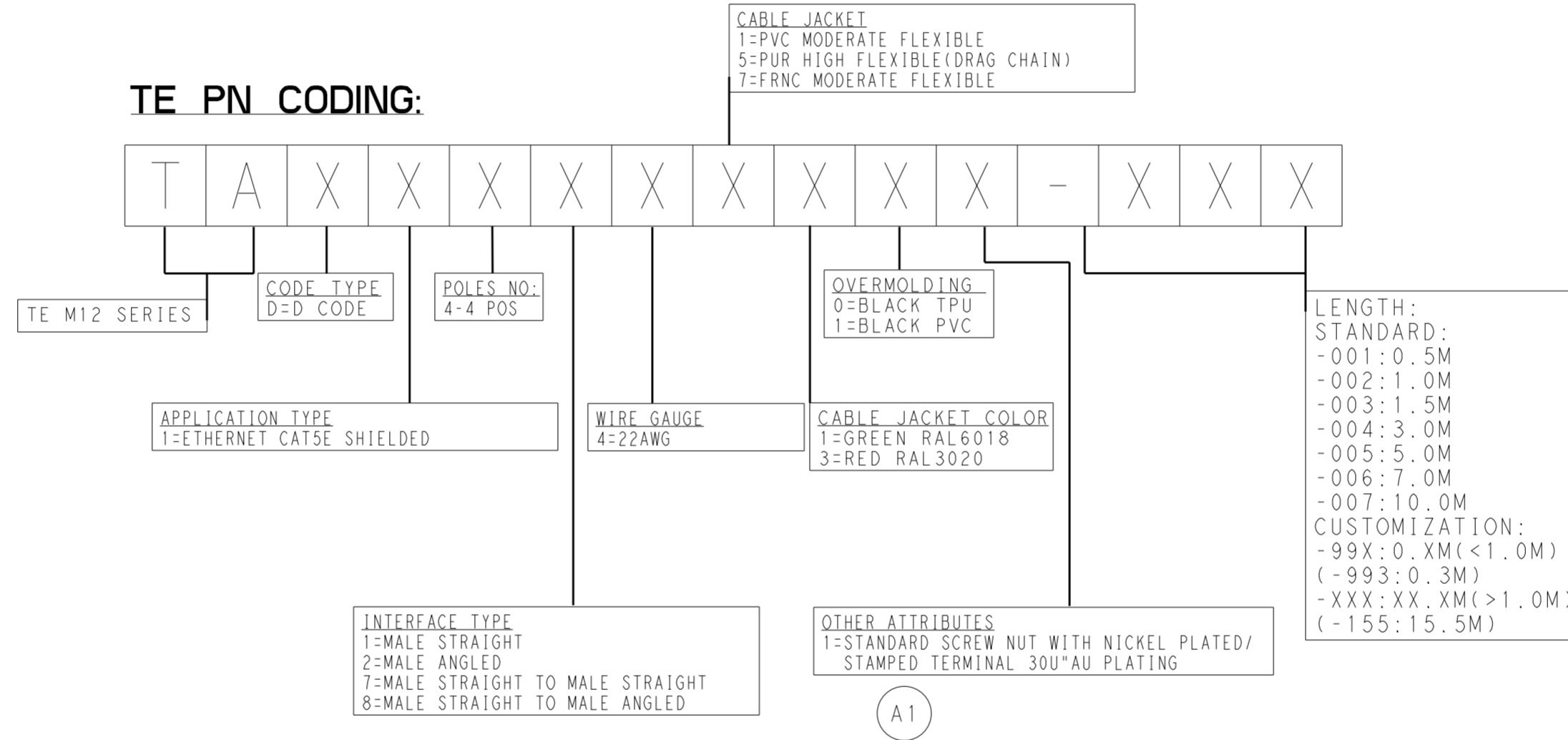

THIS DRAWING IS A CONTROLLED DOCUMENT.		DWN ALEX ZHANG 11APR2019	TE Connectivity	
DIMENSIONS: mm		CHK HART HE 11APR2019		
TOLERANCES UNLESS OTHERWISE SPECIFIED:		APVD CHRIS WANG 11APR2019	NAME M12 D CODE CABLE ASSY, SHIELDED 4P, MS FREE END	
		PRODUCT SPEC 108-106140	RESTRICTED TO	
MATERIAL		APPLICATION SPEC	SIZE A2	CAGE CODE -
		WEIGHT	DRAWING NO G-TAD1414XXXXXXX	
		RESTRICTED CUSTOMER	SCALE 2:1	SHEET 2 OF 2