

THIS DRAWING IS UNPUBLISHED. RELEASED FOR PUBLICATION 20
 © COPYRIGHT 20 BY - ALL RIGHTS RESERVED.

REVISIONS				
P	LTR	DESCRIPTION	DATE	APVD
2		REMOVE -2,-3,1-2,1-3	19FEB2019	JS EH
A		REVISED PER ECR-19-010853	16JUL2019	SR DD

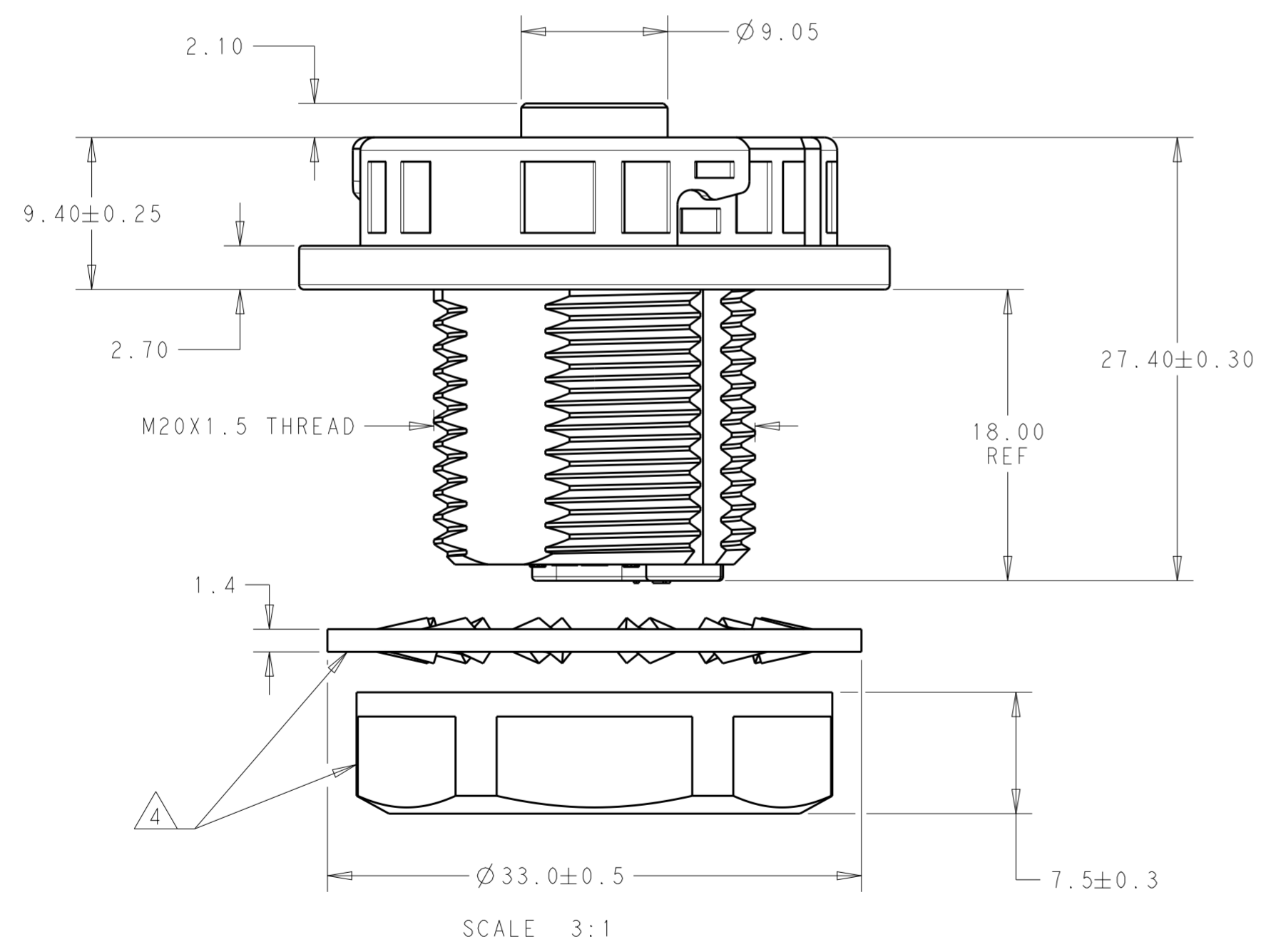
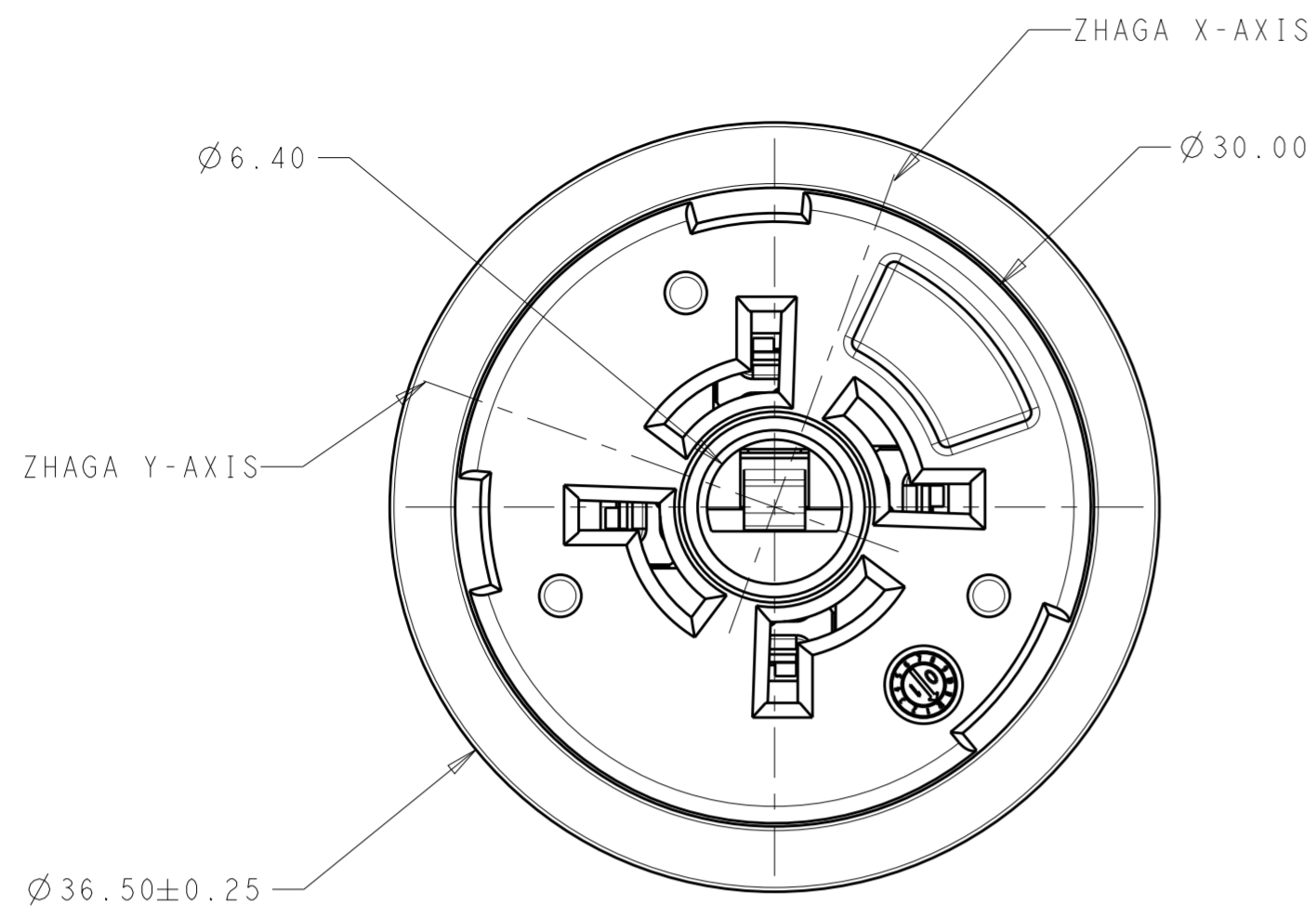

SEE SHEET 2 FOR
BOTTOM VIEW DETAIL

NOTES:

- 1 MATERIALS AND FINISH:
 -RECEPTACLE HOUSING: PBT, COLOR: BLACK
 -NUT: NYLON, COLOR: BLACK
 -CONTACTS: COPPER ALLOY, FINISH: Sn OVER Ni
 -SEAL: SILICON, COLOR: BLACK
 -STAR WASHER: STAINLESS STEEL
2. MUST COMPLY WITH DIRECTIVE 2002/95/EC (ROHS)
3. WIRE SIZE: 0.5-1.5mm² (20-16AWG); MAX INSULATION OD: $\varnothing 3.0$
 STRIP LENGTH: 11.0 \pm 1.0
- 4 LOCK WASHER (REF P/N: 2213817-1) AND NUT (REF P/N: 2213791-1)
 NOT ASSEMBLED, SHIPPED BULK PACKED.
- 5 PART NUMBER 1-2343403-1 ONLY CONTAINS COLOR CODED DOTS
 FOR CIRCUIT IDENTIFICATION.
6. MATES TO MODULE ASSEMBLIES 1-2343404-1, 2-2343404-1, 2343405-1
 AND SEALING CAP 2341474-X.

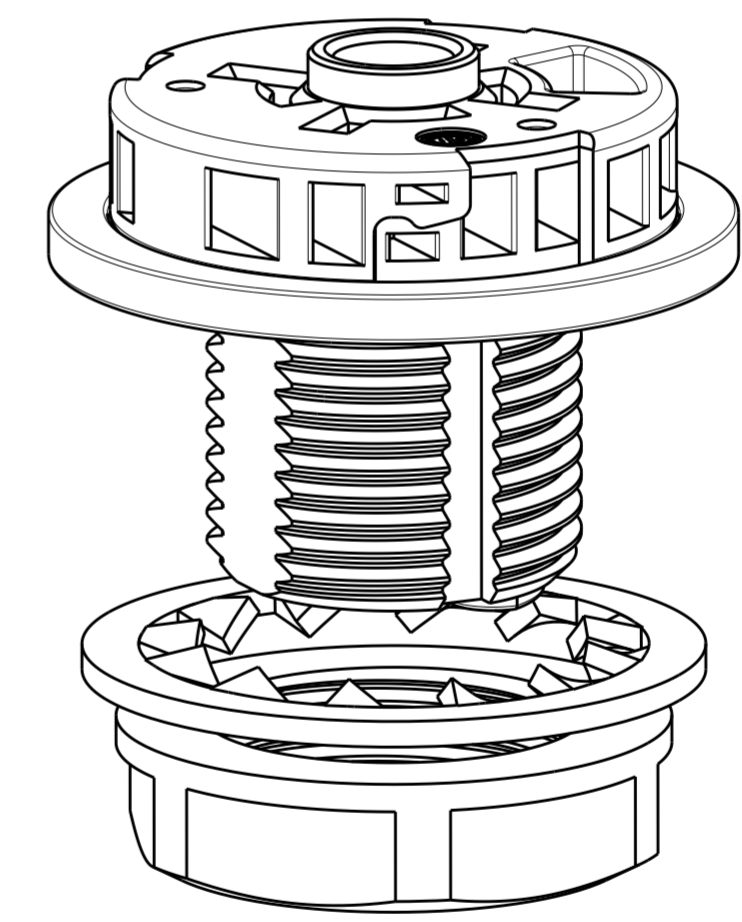

RECEPTACLE ASSY, KEY A	1-2343403-1
RECEPTACLE ASSY, KEY A	2343403-1
DESCRIPTION	PART NO.

THIS DRAWING IS A CONTROLLED DOCUMENT.		DWN C DAILY 03OCT2018	TE Connectivity	
		CHK E HOWARD 03OCT2018		
DIMENSIONS:	TOLERANCES UNLESS OTHERWISE SPECIFIED:	APVD -	NAME	RECEPTACLE ASSEMBLY, LUMAWISE ENDURANCE S, KEYED
mm	0 PLC \pm 1 PLC ± 0.2 2 PLC ± 0.15 3 PLC \pm 4 PLC \pm ANGLES ± 2 FINISH -	PRODUCT SPEC 108-133073	SIZE	A2
MATERIAL	-	APPLICATION SPEC 114-133074	CAGE CODE	-
		WEIGHT	DRAWING NO	C-2343403
		CUSTOMER DRAWING	SCALE	1:1
			SHEET	1 OF 3
			REV	A

THIS DRAWING IS UNPUBLISHED. RELEASED FOR PUBLICATION 20
 © COPYRIGHT 20 BY - ALL RIGHTS RESERVED.

REVISIONS				
P	LTR	DESCRIPTION	DATE	APVD
-	-	SEE SHEET 1	-	-

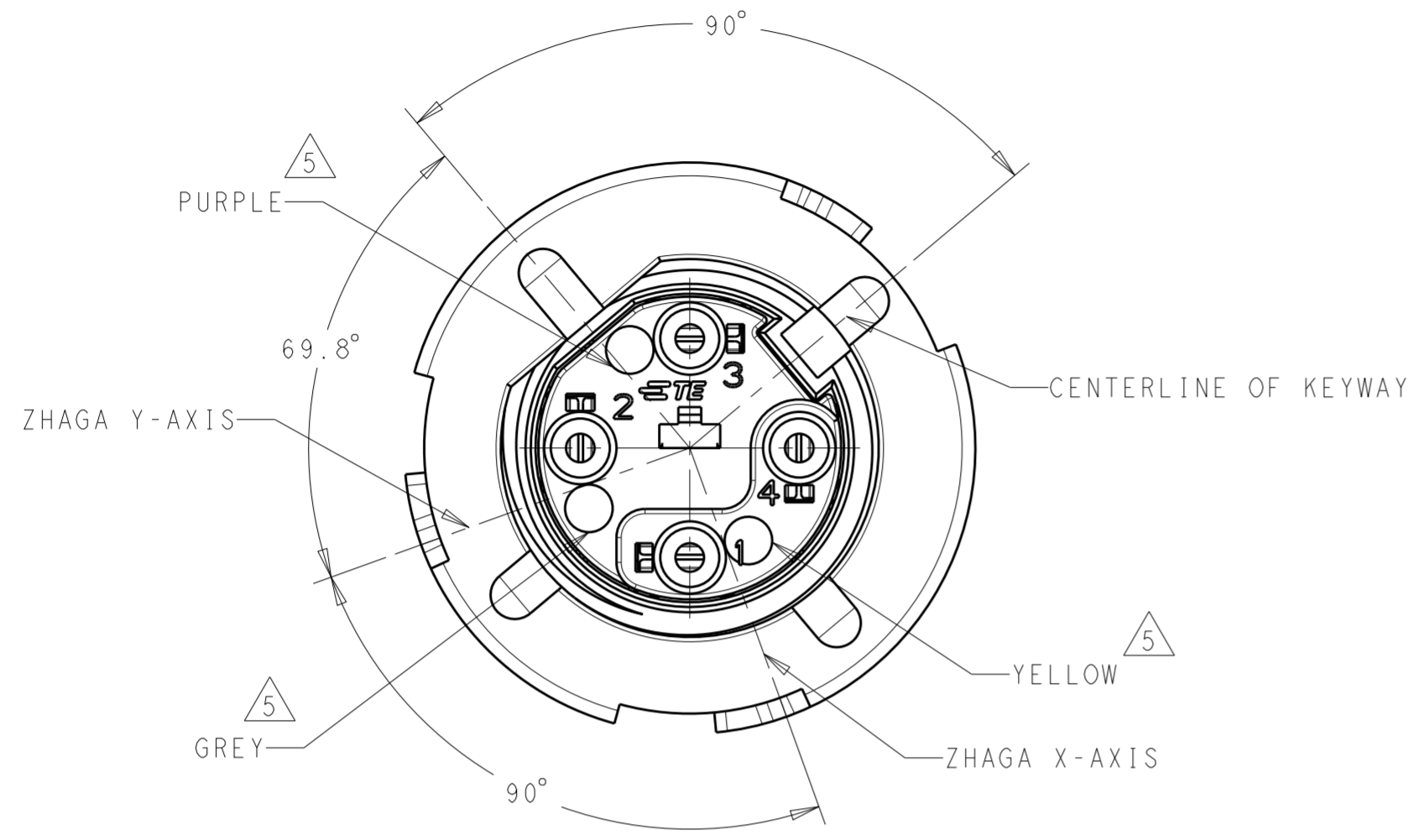

BOTTOM VIEW
 (GASKET, NUT AND WASHER NOT SHOWN FOR CLARITY)

1-2343403-1 SHOWN

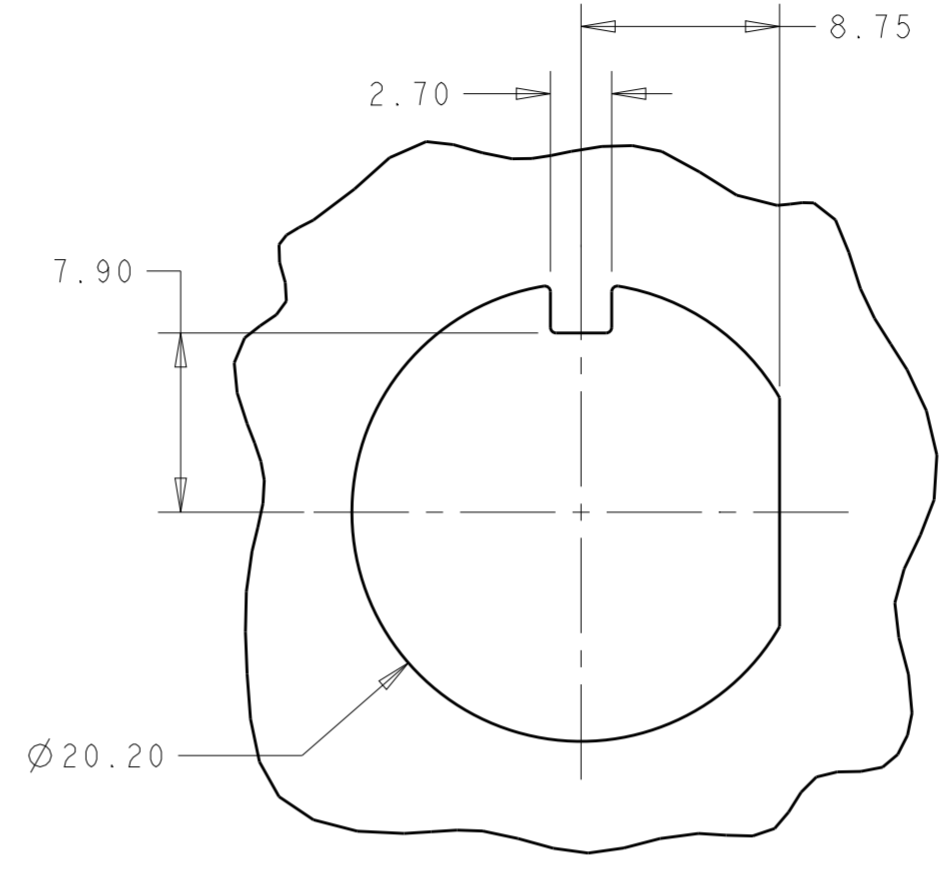

RECEPTACLE CUTOUT
 SCALE 3:1

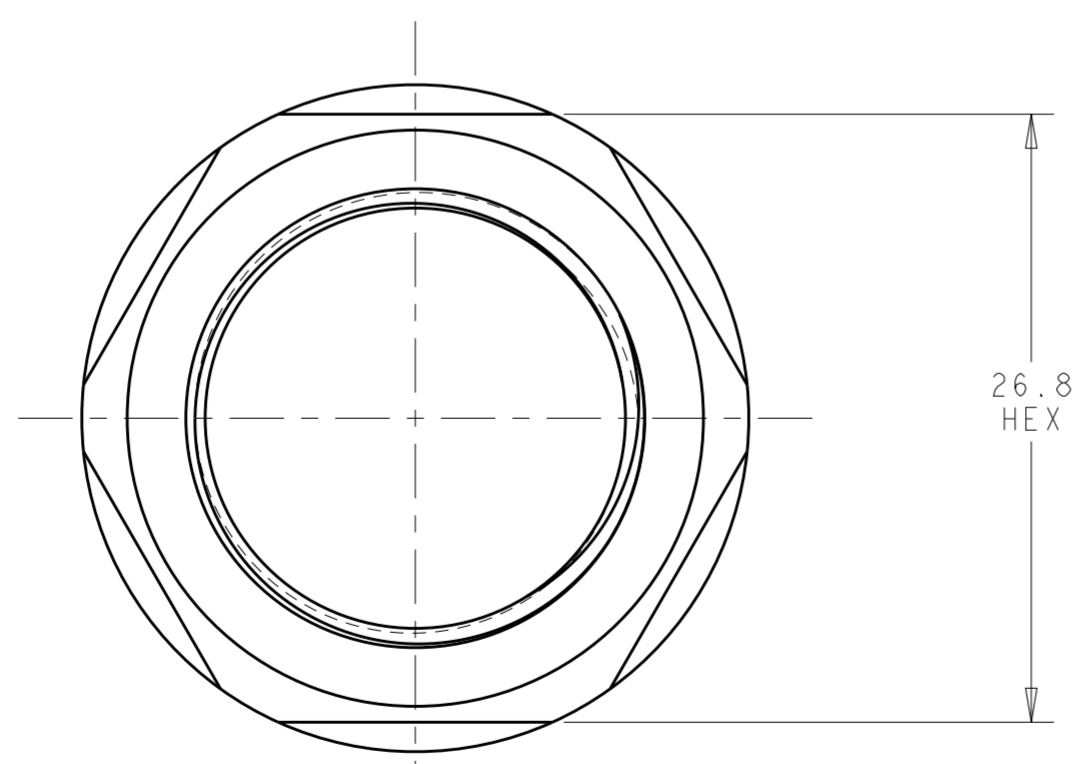

LOCKING NUT DETAIL
 SCALE: 3:1

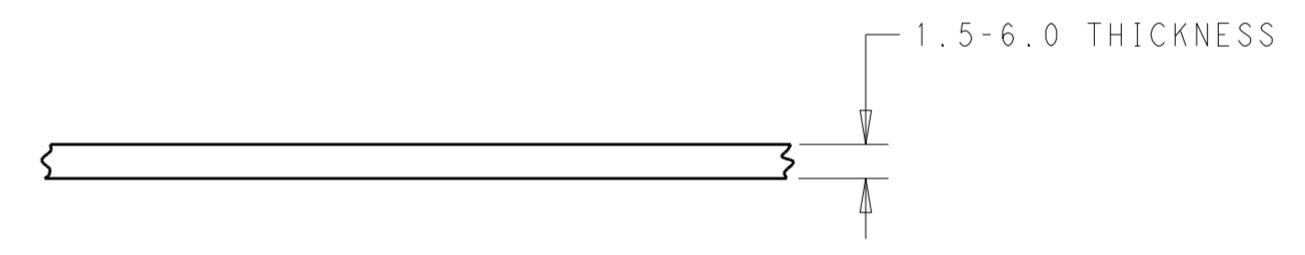

THIS DRAWING IS A CONTROLLED DOCUMENT.		DWN C. DAILY 03OCT2018	TE Connectivity	
		CHK E. HOWARD 03OCT2018		
DIMENSIONS:		APVD -	NAME RECEPTACLE ASSEMBLY, LUMAWISE ENDURANCE S, KEYED	
mm	TOLERANCES UNLESS OTHERWISE SPECIFIED:	PRODUCT SPEC 108-133073	SIZE A2	
	0 PLC ±	APPLICATION SPEC 114-133074	CAGE CODE -	DRAWING NO C-2343403
	1 PLC ±0.2	WEIGHT -	RESTRICTED TO -	
	2 PLC ±0.15	CUSTOMER DRAWING	SCALE 1:1	SHEET 2 OF 3
	3 PLC ±		REV A	
	4 PLC ±			
	ANGLES ±2			
	FINISH			

THIS DRAWING IS UNPUBLISHED. RELEASED FOR PUBLICATION 20
 © COPYRIGHT 20 BY - ALL RIGHTS RESERVED.

REVISIONS				
P	LTR	DESCRIPTION	DATE	APVD
-	-	SEE SHEET 1	-	-

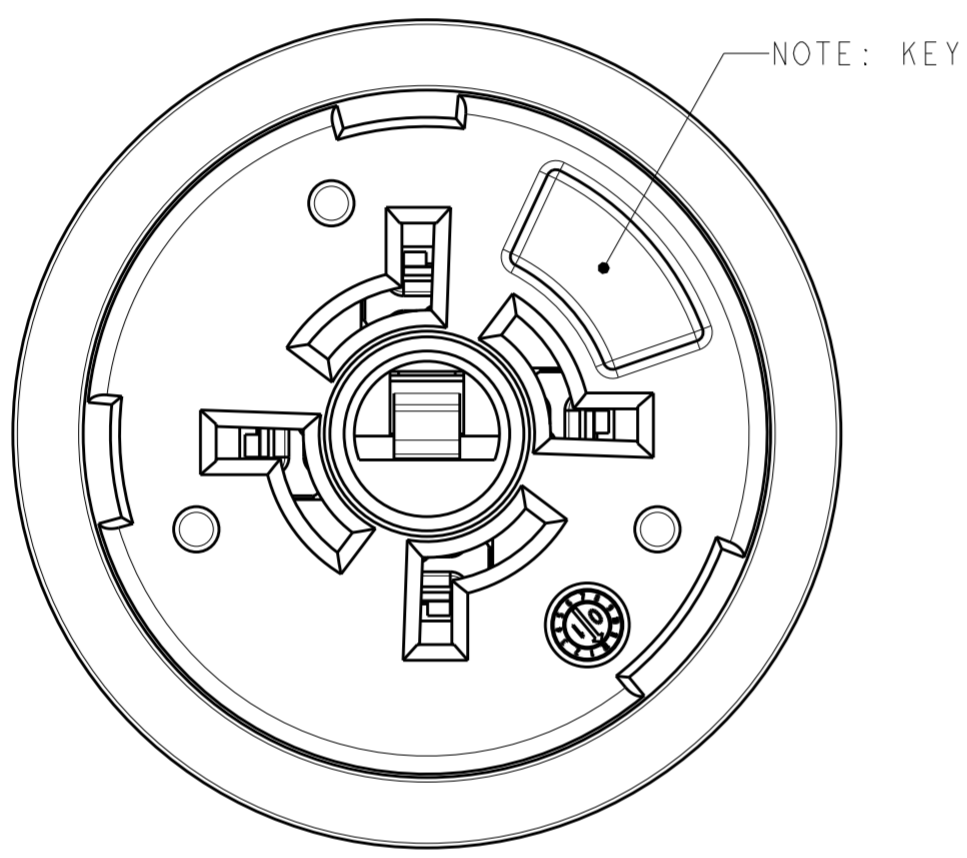

2343403-1 AND 1-2343403-1
 KEY POSITION A
 SCALE 3:1

THIS DRAWING IS A CONTROLLED DOCUMENT.		DWN C. DAILY 03OCT2018	TE Connectivity	
		CHK E. HOWARD 03OCT2018		
DIMENSIONS: mm		APVD -	NAME RECEPTACLE ASSEMBLY, LUMAWISE ENDURANCE S, KEYED	
		PRODUCT SPEC 108-133073	RESTRICTED TO -	
TOLERANCES UNLESS OTHERWISE SPECIFIED: 0 PLC ± 1 PLC ±0.2 2 PLC ±0.15 3 PLC ± 4 PLC ± ANGLES ± FINISH ±2		APPLICATION SPEC 114-133074	SIZE A2	CAGE CODE -
MATERIAL	-	WEIGHT	DRAWING NO C-2343403	SCALE 1:1
		CUSTOMER DRAWING	SHEET 3 OF 3	REV A