

This document is the property of Amphenol Corporation and is delivered on the express condition that it is not to be disclosed, reproduced or used, in whole or in part, for manufacture or sale by anyone other than Amphenol Corporation without its prior consent, and that no right is granted to disclose or to use any information in this document.

The marking on this product doesn't contain environmental hazardous materials per Material Specification SS-00259 for Sony GP compliant or per directive 2011/65/EU for RoHS compliant.



CUSTOMER DRAWING ORIGINAL

Package Drawing

REVISIONS				
SYM	ECN No.	DESCRIPTION	DATE	APPROVED
A	NE-13104	NEW RELEASE	07/09/2013	Roger Tsai
B	NE-16127	CHANGE THE SHELL SHAPE	05/24/2016	Roger Tsai

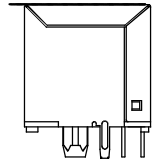

RJMG1V200T1015R

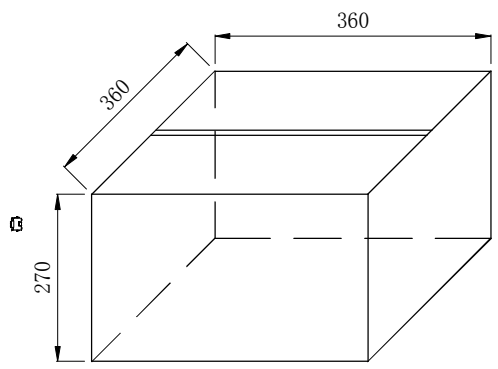

CARTON

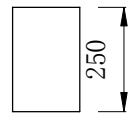
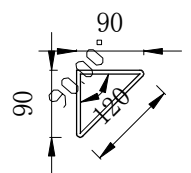
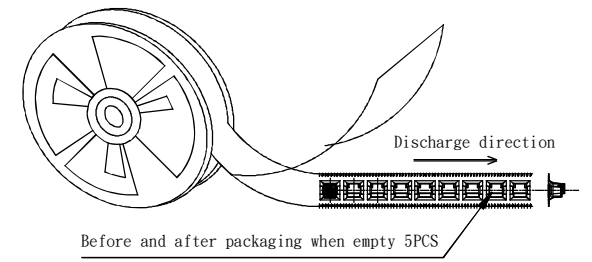
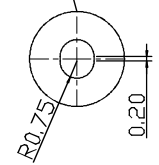
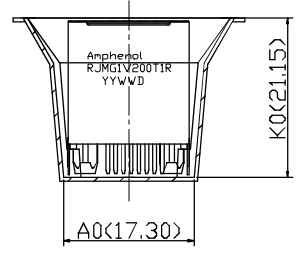
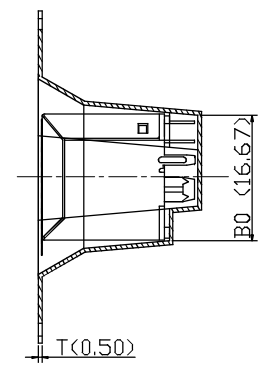
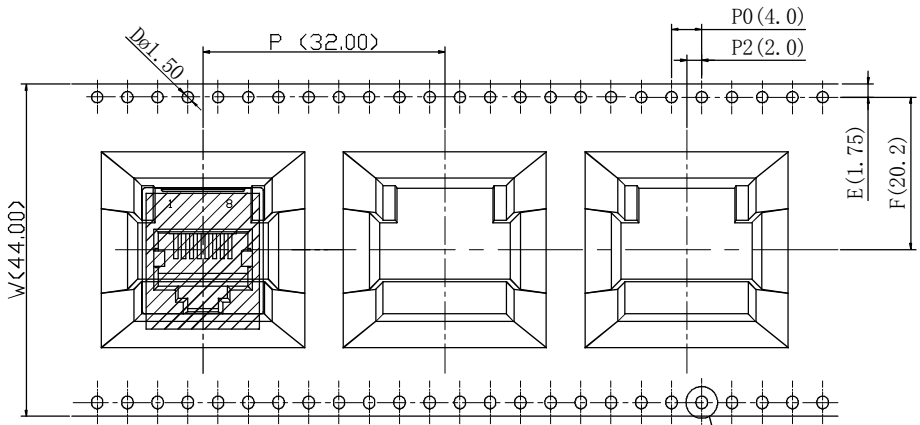

Triangular plate

ITRM	W	A0	B0	K0	P	F	E	D	P0	P2	T	Tape & Reel	
DIM	44.0	17.30	16.67	21.15	32.0	20.2	1.75	1.50	4.00	2.00	0.50	LENGTH/TRAY	PART/TRAY
TQLE	+0.30 -0.30	+0.15 -0.15	+0.15 -0.15	+0.10 -0.10	+0.10 -0.10	+0.15 -0.15	+0.10 -0.10	+0.10 -0.00	+0.10 -0.10	+0.15 -0.15	+0.05 -0.05	3.52M	100PCS

TOLERANCE	APPROVALS	DATE	TITLE	UNIT	SIZE	PART No.
X. X.X ±0.35 X.XX ±0.25 X.XXX ±0.15	DRAWN Jophy Li	05/24/2016	RJMG1V Series 10/100 Base-T Top Enter Single Port without LED options	mm	A3	RJMG1V200T1015R
ANGULAR ±1°	CHECKED Vivian Wen	05/24/2016				
UNLESS OTHERWISE SPECIFIED	APPROVED Roger Tsai	05/24/2016				
	DWG TYPE CUST DWG	PROJECT CODE -	SCALE NA	SHEET 2 OF 2	DWG No. RJMG1V200T1015R	REV. B

