

THIS DRAWING IS UNPUBLISHED. RELEASED FOR PUBLICATION 20  
 © COPYRIGHT 20 BY - ALL RIGHTS RESERVED.

REVISIONS

P	LTR	DESCRIPTION	DATE	DWN	APVD
	A	INITIAL RELEASE	14APR2015	DL	CW
	B	ECR-15-018481	19FEB2016	DL	CW
	B1	ECR-17-002385	20FEB2017	QY	CW

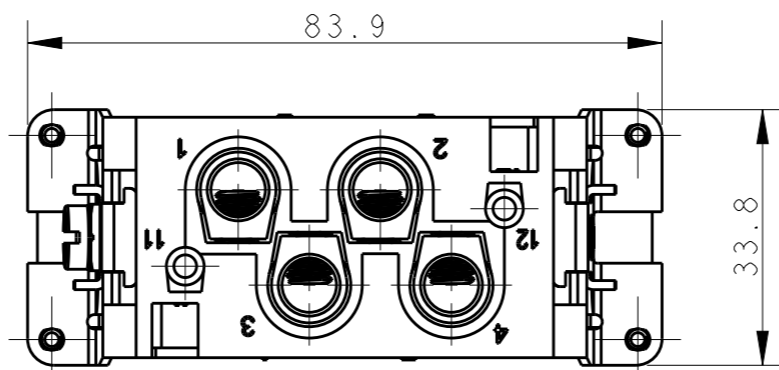
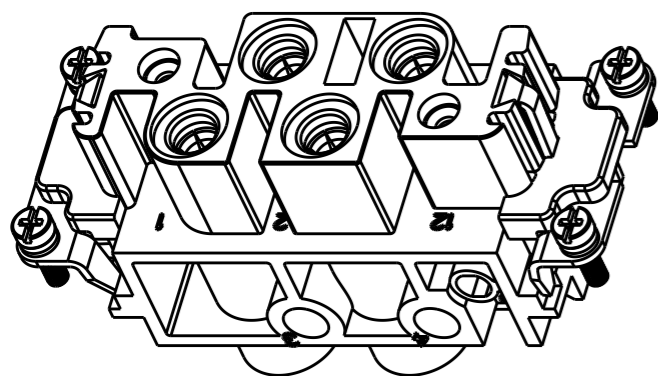

NOTES:  
 1. TECHNICAL CHARACTERISTICS:  
 INSULATION MATERIAL: PC  
 RATED VOLTAGE: 690 V  
 RATED CURRENT: 80 A  
 INSULATION RESISTANCE:  $\geq 400M\Omega$   
 RATED IMPULSE VOLTAGE: 8 KV  
 POLLUTION DEGREE: 3  
 FLAMMABILITY: UL94V-0  
 MATING CYCLES: 500  
 WIRE RANGE: POWER: 1.5-16 mm<sup>2</sup> (16-5 AWG)  
 CONTACT FINISH: SILVER PLATED  
 CONTACT TYPE: SCREW CONTACT

M5 SCREW, RECOMMENDED  
 TIGHTENING TORQUE 2.0Nm  
 M5螺丝, 推荐锁紧力矩2.0Nm

4X M3 SCREW, RECOMMENDED  
 TIGHTENING TORQUE 0.5Nm  
 4X M3螺丝, 推荐扭力矩为 0.5Nm

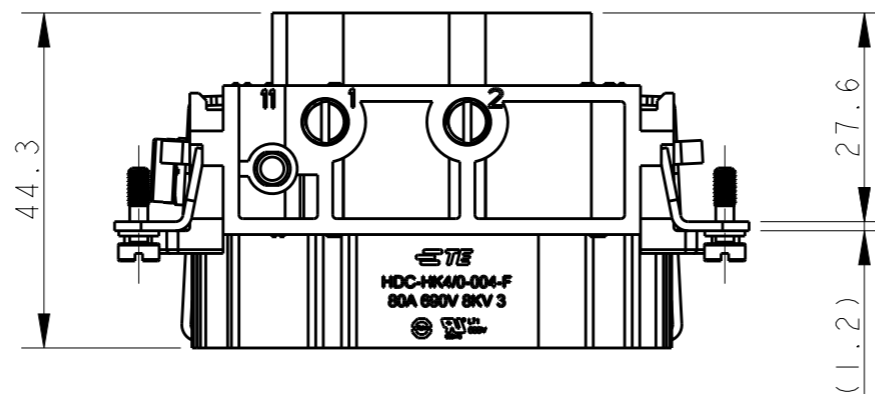
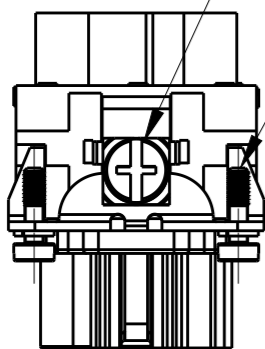

注释:  
 1. 技术参数:  
 绝缘材料: PC  
 额定电压: 690 V  
 额定电流: 80 A  
 绝缘电阻:  $\geq 400M\Omega$   
 额定脉冲电压: 8 KV  
 污染等级: 3  
 阻燃等级: UL94V-0  
 插拔次数: 500次  
 接线范围: 1.5-16 mm<sup>2</sup> (16-5 AWG)  
 端子表面处理: 镀银  
 接线类型: 螺丝压接

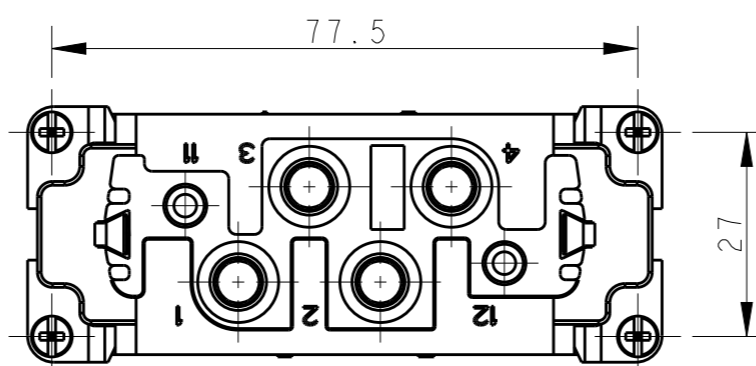
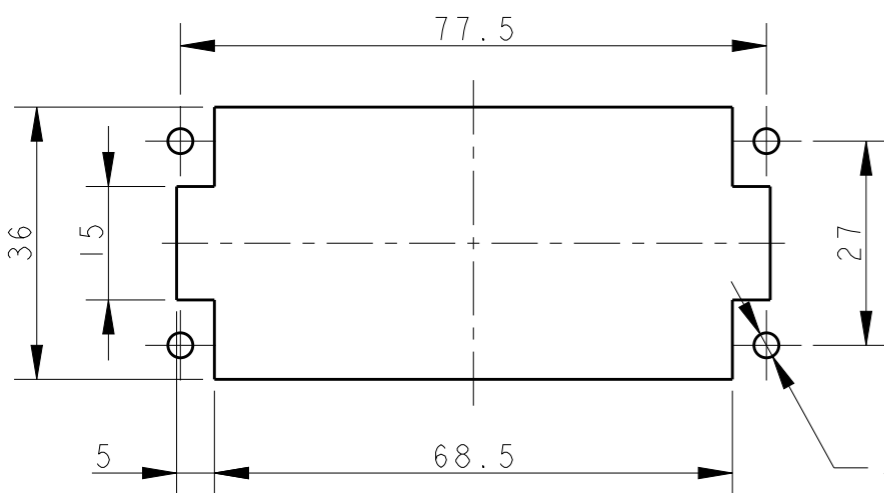

PANEL CUT OUT FOR INSERTS FOR USING  
 WITHOUT HOODS/HOUSINGS  
 不使用防护外壳时芯件的安装开孔图

THIS DRAWING IS A CONTROLLED DOCUMENT.		DWN DAVID LI 14APR2015		 TE Connectivity	
DIMENSIONS: mm		CHK CHRIS WANG 14APR2015			
TOLERANCES UNLESS OTHERWISE SPECIFIED:		APVD XU XIANG 14APR2015		NAME	
0 PLC ±-		PRODUCT SPEC		HK4/0-004-F	
1 PLC ±-		108-137127		SIZE	
2 PLC ±-		APPLICATION SPEC		CAGE CODE	
3 PLC ±-		114-137127		DRAWING NO	
4 PLC ±-		WEIGHT		RESTRICTED TO	
ANGLES ±-		CUSTOMER DRAWING		-	
FINISH		SCALE 1:1		SHEET 1 OF 2	
-		-		REV B1	

4

3

2

1

THIS DRAWING IS UNPUBLISHED.

RELEASED FOR PUBLICATION

20

© COPYRIGHT 20 BY -

ALL RIGHTS RESERVED.

REVISIONS

P	LTR	DESCRIPTION	DATE	DWN	APVD
-		SEE SHEET 1	-	-	-

ALL DIMENSIONS ARE SAME AS TYPE 1,  
EXCEPT THOSE DEFINED IN THIS TYPE.  
除了在本类型中定义的尺寸外, 其它尺寸同类型 |

NOTES:

SEE SHEET 1

注释:  
见页 |

M5 SCREW, RECOMMENDED  
TIGHTENING TORQUE 2.0Nm  
M5螺丝, 推荐锁紧力矩2.0Nm

4X M3 SCREW, RECOMMENDED  
TIGHTENING TORQUE 0.5Nm  
4X M3螺丝, 推荐扭力矩为 0.5Nm

TYPE-2: T2100042201-001 STAINLESS STEEL SCREW, NO LOGO  
类型-2: T2100042201-001 不锈钢螺丝, 无LOGO

T2100042201-001	HK4/0-004-F	HK4/0-004 FEMALE INSERT, STAINLESS STEEL SCREW, NO LOGO HK4/0-004母插, 不锈钢螺丝, 无LOGO	TYPE-2 类型-2
T2100042201-000	HK4/0-004-F	HK4/0-004 FEMALE INSERT HK4/0-004母插	TYPE-1 类型-1
PART NUMBER 料号	PART DESCRIPTION 描述		TYPE 类型

THIS DRAWING IS A CONTROLLED DOCUMENT.		DWN DAVID LI 14APR2015	 TE Connectivity		
DIMENSIONS: mm		CHK CHRIS WANG 14APR2015			NAME HK4/0-004-F
TOLERANCES UNLESS OTHERWISE SPECIFIED:		APVD XU XIANG 14APR2015			PRODUCT SPEC 108-137127
0 PLC ±- 1 PLC ±- 2 PLC ±- 3 PLC ±- 4 PLC ±- ANGLES ±-		APPLICATION SPEC 114-137127			SIZE A3
MATERIAL -	FINISH -	WEIGHT -	CAGE CODE -	DRAWING NO T2100042201000	RESTRICTED TO -
CUSTOMER DRAWING			SCALE 1:1	SHEET 2 OF 2	REV B1

1470-19 (3/13)