

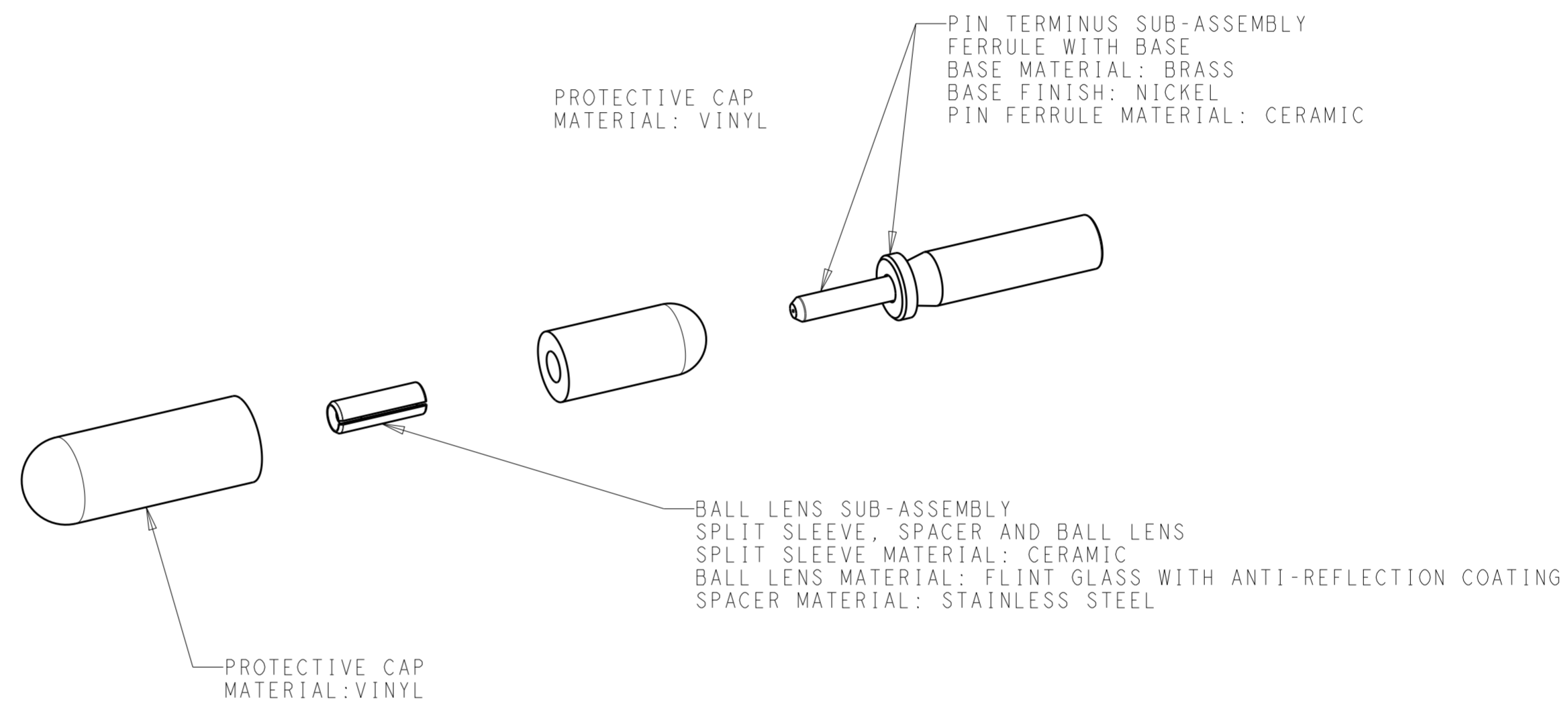

THIS DRAWING IS UNPUBLISHED. RELEASED FOR PUBLICATION 20  
 © COPYRIGHT 20 BY - ALL RIGHTS RESERVED.

REVISIONS				
P	LTR	DESCRIPTION	DATE	APVD
	A	RELEASED	18NOV2019	DF SM

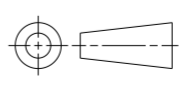

2332897-1  
 PART NUMBER

THIS DRAWING IS A CONTROLLED DOCUMENT.		DWN 14NOV2018 D. FABIAN	 TE Connectivity		
DIMENSIONS: mm 		CHK -			APVD -
TOLERANCES UNLESS OTHERWISE SPECIFIED: 0 PLC ± 1 PLC ± 2 PLC ±0.13 3 PLC ±0.013 4 PLC ± ANGLES ±1 FINISH -		APVD -	PRODUCT SPEC -	APPLICATION SPEC -	
MATERIAL -		WEIGHT -	SIZE A200779	DRAWING NO C-2332897	RESTRICTED TO -
CUSTOMER DRAWING			SCALE 4:1	SHEET 1 OF 1	REV A