

Jul.1.2020 Copyright 2020 HIROSE ELECTRIC CO., LTD. All Rights Reserved.  
 In case of consideration for using Automotive equipment / device which demand high reliability, kindly contact our sales window correspondents.

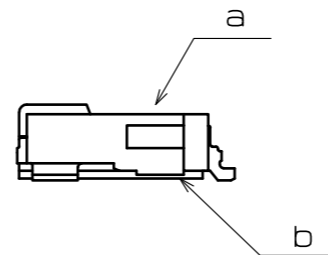

RECOMMENDED PCB MOUNTING PATTERN

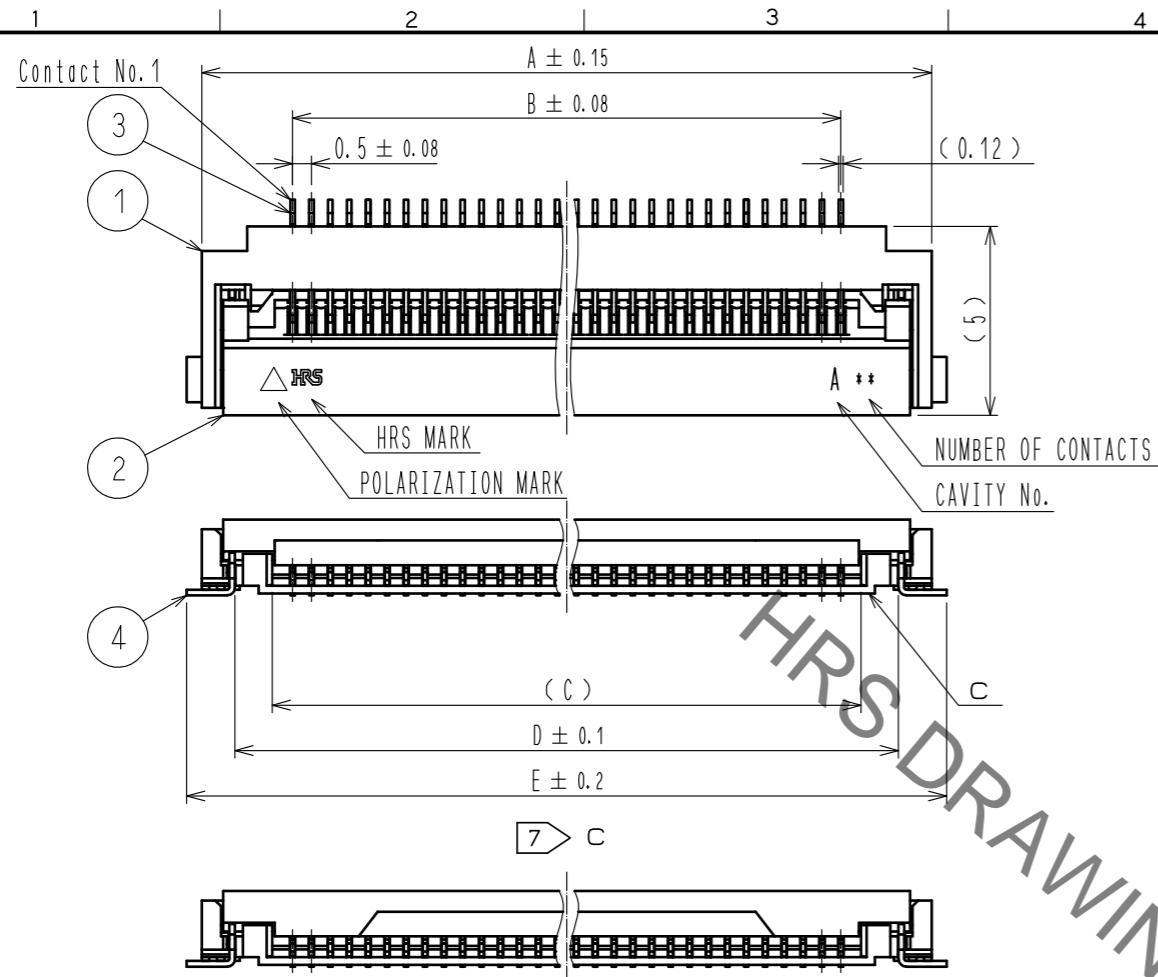
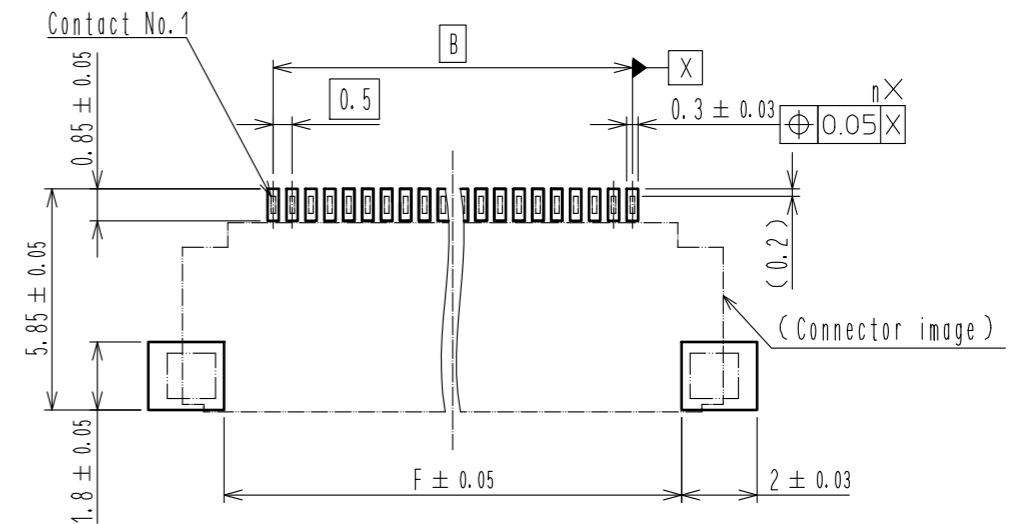

RECOMMENDED STENCIL PATTERN  
 (RECOMMENDED STENCIL THICKNESS :  $t=0.12$ )

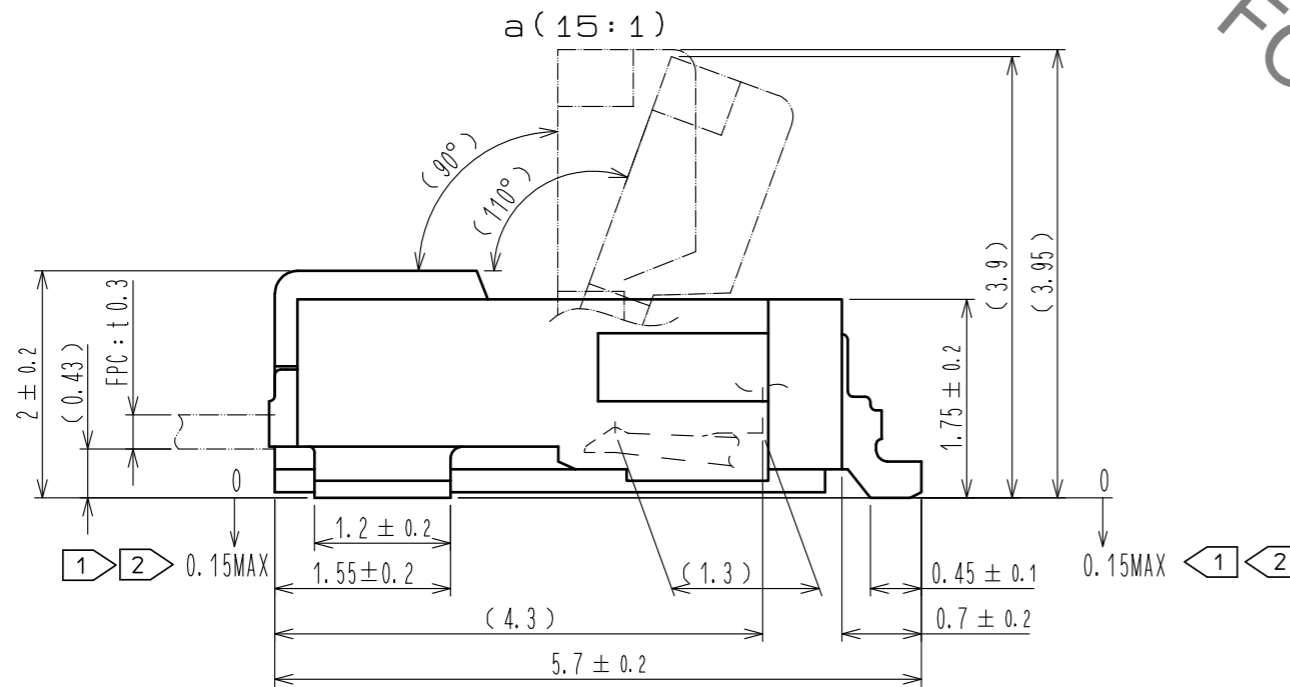
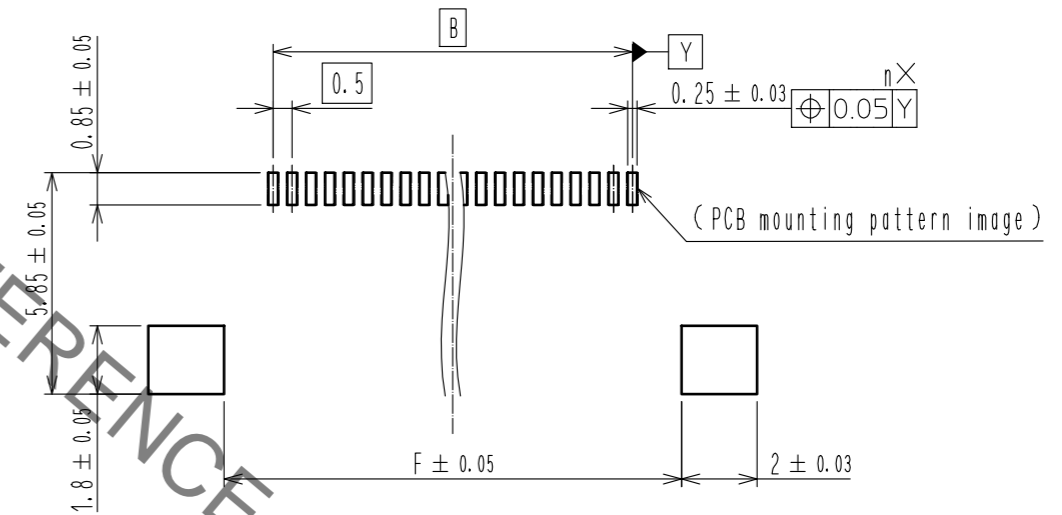

- NOTES
- 1 Lead CO-PLANARITY including reinforced metal fittings shall be 0.1 MAX.
  - 2 Dimension: from reference b.
  3. To be delivered with tape and reel packages.
  4. Note that preventive hole for sink mark could be added for improvement.
  5. The quality remains good. Even with the dark spots, which could occasionally occur molded plastics.
  6. This product satisfies halogen free requirements defined as 900ppm maximum chlorine, 900ppm maximum bromine, and 1500ppm maximum total of chlorine and bromine.
  - 7 Shows actuator configuration of 60 pos.
  8. 'n' represents the number of contacts.
  9. The dimension in parentheses are for reference.

4	BRASS	TIN PLATING 3#m MIN OVER NICKEL 1#m MIN	8	(CONNECTOR)	
3	COPPER ALLOY	(CONTACT AREA, LEAD) GOLD 0.03#mMIN OVER NICKEL 1#mMIN (OTHER) NICKEL PLATING 1#mMIN	7	POLYSTYRENE	
2	LCP	BLACK UL94V-0	6	POLYESTER	
1	LCP	GRAY UL94V-0	5	POLYSTYRENE	
NO.	MATERIAL	FINISH . REMARKS	NO.	MATERIAL	FINISH . REMARKS
UNITS mm		SCALE 5 : 1	COUNT 11	DESCRIPTION OF REVISIONS DIS-F-00004887	DESIGNED TA. SUZUKI
					CHECKED FN. TAMURA
					DATE 20190712
<b>HRS</b> HIROSE ELECTRIC CO., LTD.		APPROVED : NF. MIYAZAKI 20160330	DRAWING NO. EDC-365730-00-01		
		CHECKED : HS. SAKAMOTO 20160330	PART NO. FH52K-**S-0.5SH		
		DESIGNED : HK. KINOUCHI 20160330	CODE NO. CL580		
		DRAWN : RK. OGASAWARA 20160330			

Jul.1.2020 Copyright 2020 HIROSE ELECTRIC CO., LTD. All Rights Reserved.  
 In case of consideration for using Automotive equipment / device which demand high reliability, kindly contact our sales window correspondents.

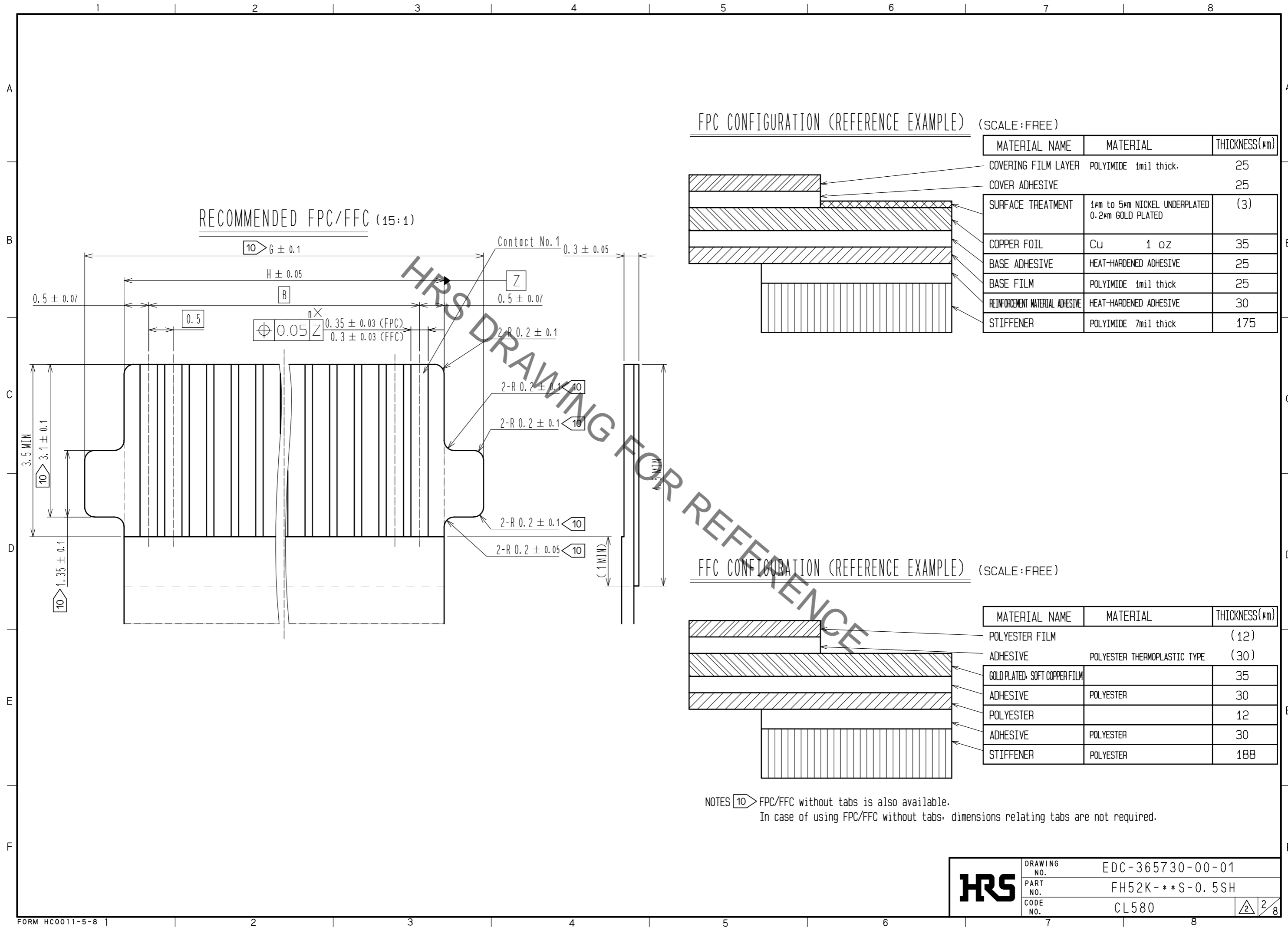

RECOMMENDED FPC/FFC (15:1)

FPC CONFIGURATION (REFERENCE EXAMPLE) (SCALE:FREE)

MATERIAL NAME	MATERIAL	THICKNESS(μm)
COVERING FILM LAYER	POLYIMIDE 1mil thick.	25
COVER ADHESIVE		25
SURFACE TREATMENT	1μm to 5μm NICKEL UNDERPLATED 0.2μm GOLD PLATED	(3)
COPPER FOIL	CU 1 oz	35
BASE ADHESIVE	HEAT-HARDENED ADHESIVE	25
BASE FILM	POLYIMIDE 1mil thick	25
REINFORCEMENT MATERIAL ADHESIVE	HEAT-HARDENED ADHESIVE	30
STIFFENER	POLYIMIDE 7mil thick	175

FFC CONFIGURATION (REFERENCE EXAMPLE) (SCALE:FREE)

MATERIAL NAME	MATERIAL	THICKNESS(μm)
POLYESTER FILM		(12)
ADHESIVE	POLYESTER THERMOPLASTIC TYPE	(30)
GOLD PLATED SOFT COPPER FILM		35
ADHESIVE	POLYESTER	30
POLYESTER		12
ADHESIVE	POLYESTER	30
STIFFENER	POLYESTER	188

NOTES  $\text{10}$  FPC/FFC without tabs is also available.  
 In case of using FPC/FFC without tabs, dimensions relating tabs are not required.

<b>HRS</b>	DRAWING NO.	EDC-365730-00-01
	PART NO.	FH52K-***S-0.5SH
	CODE NO.	CL580

Jul.1.2020 Copyright 2020 HIROSE ELECTRIC CO., LTD. All Rights Reserved.  
 In case of consideration for using Automotive equipment / device which demand high reliability, kindly contact our sales window correspondents.

EMBOSSED CARRIER TAPE DIMENSION (2:1)

REEL DIMENSIONS (No Scale)

TAPE WIDTH : 24mm MAX

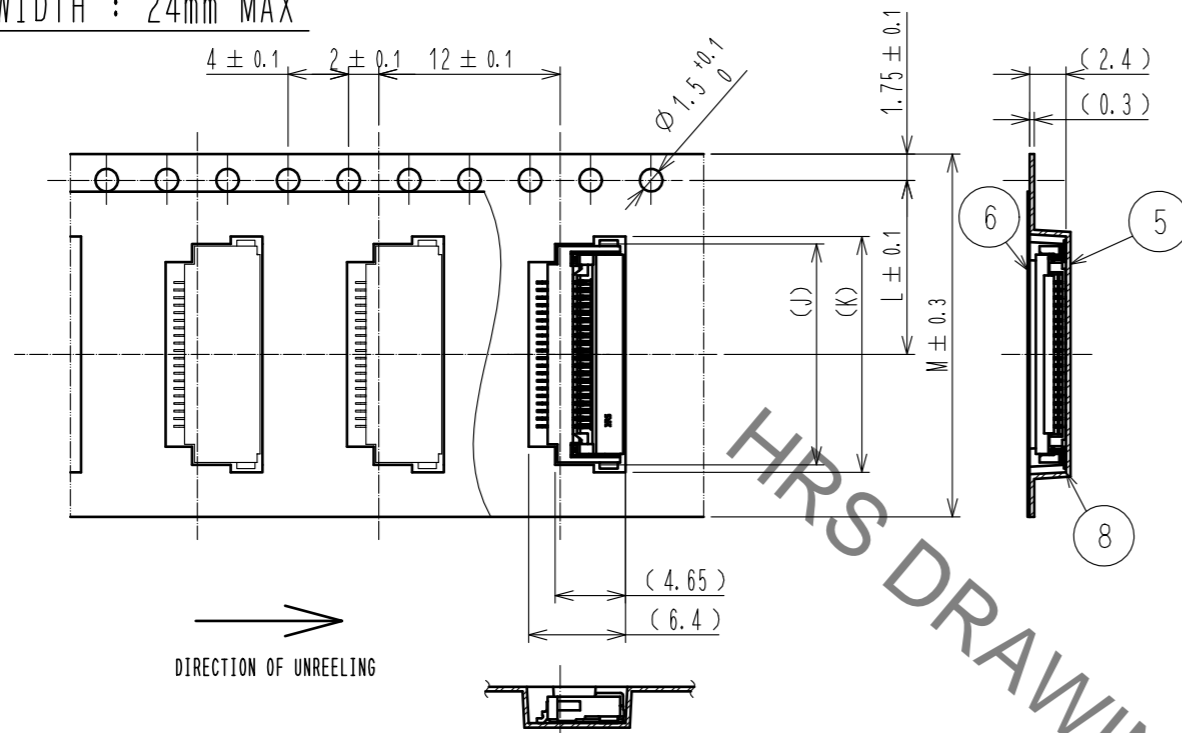

TAPE WIDTH : 32mm MIN

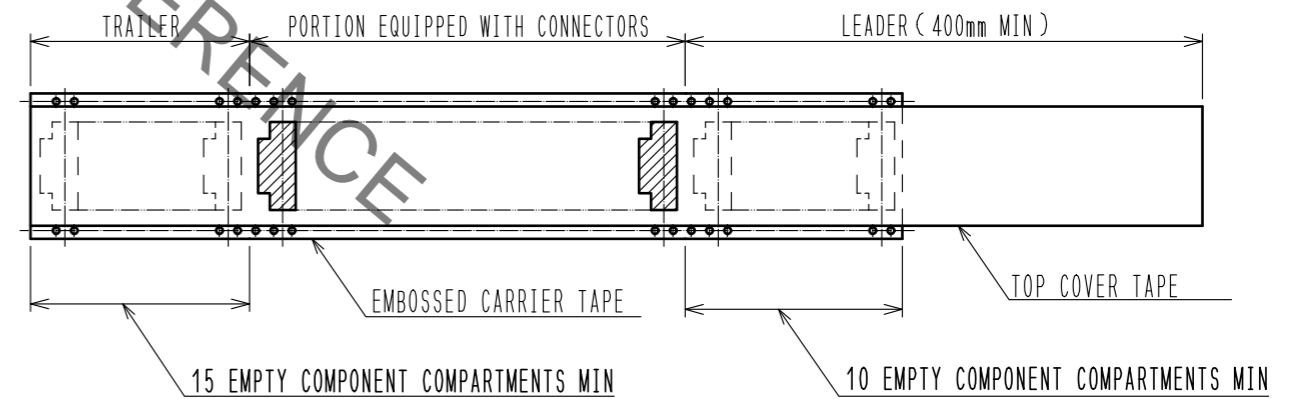
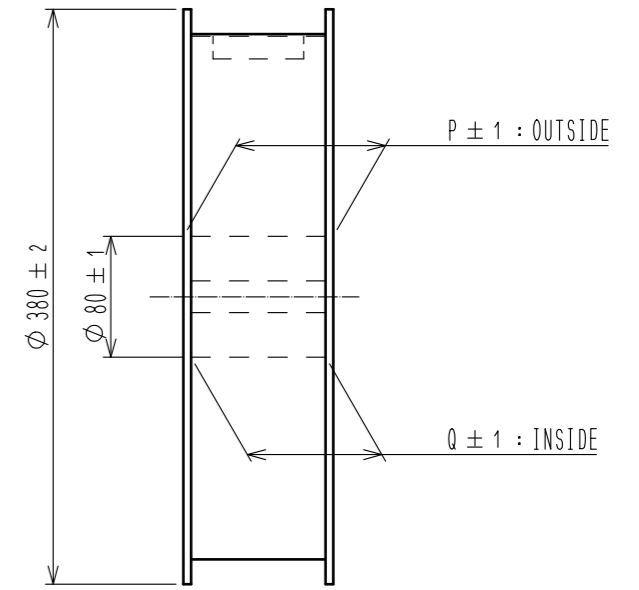
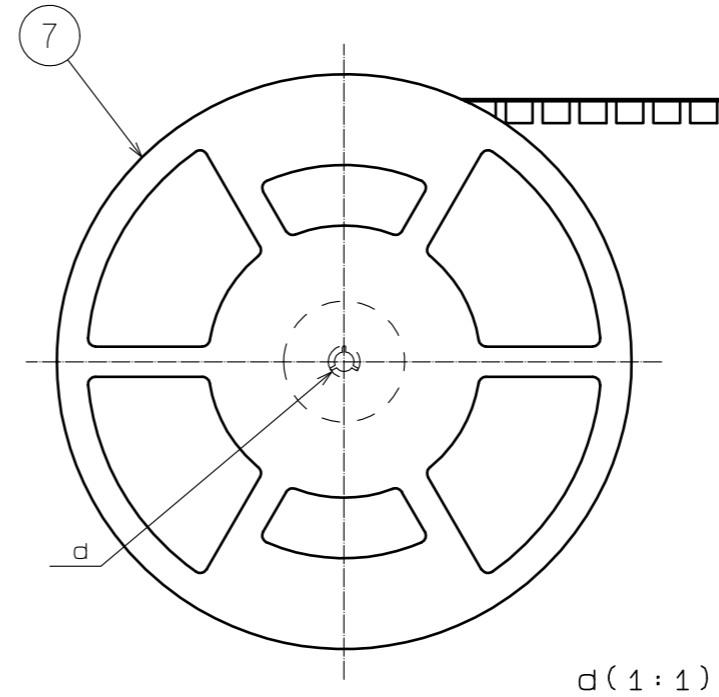
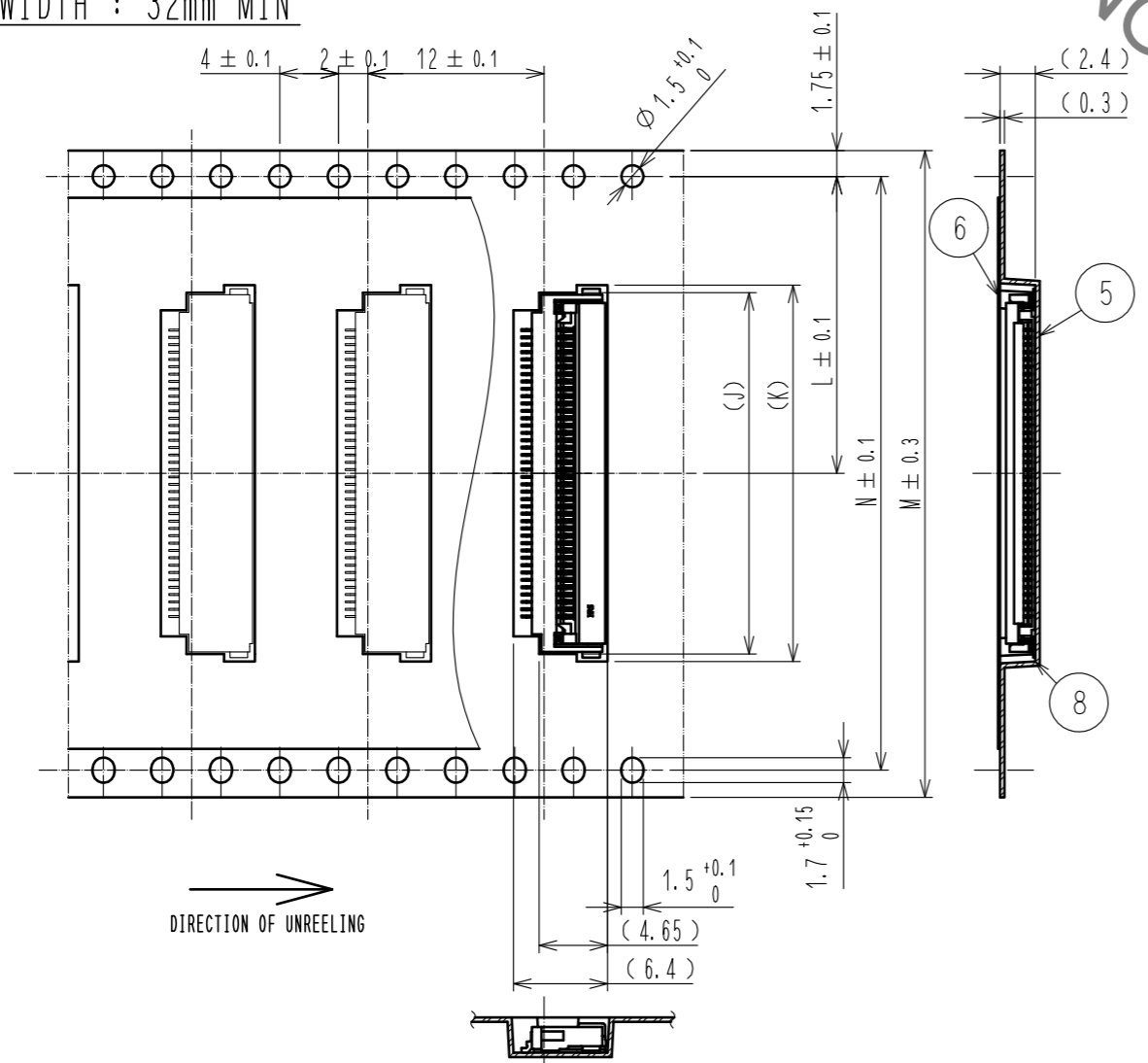

- NOTES
11. 1 reel : 3000 connectors.
  12. Refer to JIS C 0806 and IEC 60286-3 (Packaging of components for automatic handling.)

<b>HRS</b>	DRAWING NO.	EDC-365730-00-01
	PART NO.	FH52K-***S-0.5SH
	CODE NO.	CL580
		3/8

Jul.1.2020 Copyright 2020 HIROSE ELECTRIC CO., LTD. All Rights Reserved.  
 In case of consideration for using Automotive equipment / device which demand high reliability, kindly contact our sales window correspondents.

PART NO.	CODE NO.	NUMBER OF CONTACT	DIMENSION OF CONNECTOR, PCB MOUNTING PATTERN, STENCIL PATTERN AND FFC/FPC								DIMENSION OF DRAWING FOR PACKING						
			A	B	C	D	E	F	G	H	J	K	L	M	N	P	Q
FH52K-6S-0.5SH	CL580-4613-0-00	6	7.3	2.5	3.57	5.55	8.1	5.1	5.1	3.5	7.6	8.6	11.5	24.0	—	29.4	25.4
FH52K-8S-0.5SH	CL580-4611-0-00	8	8.3	3.5	4.57	6.55	9.1	6.1	6.1	4.5	8.6	9.6	11.5	24.0	—	29.4	25.4
FH52K-10S-0.5SH	CL580-4606-0-00	10	9.3	4.5	5.57	7.55	10.1	7.1	7.1	5.5	9.6	10.6	11.5	24.0	—	29.4	25.4
△ FH52K-12S-0.5SH	CL580-4629-0-00	12	10.3	5.5	6.57	8.55	11.1	8.1	8.1	6.5	10.6	11.6	11.5	24.0	—	29.4	25.4
△ FH52K-15S-0.5SH	CL580-4617-0-00	15	11.8	7.0	8.07	10.05	12.6	9.6	9.6	8.0	12.1	13.1	11.5	24.0	—	29.4	25.4
△ FH52K-18S-0.5SH	CL580-4636-0-00	18	13.3	8.5	9.57	11.55	14.1	11.1	11.1	9.5	13.6	14.6	11.5	24.0	—	29.4	25.4
△ FH52K-20S-0.5SH	CL580-4604-0-00	20	14.8	9.5	10.57	12.55	15.1	12.1	12.1	10.5	14.6	15.6	11.5	24.0	—	29.4	25.4
△ FH52K-22S-0.5SH	CL580-4632-0-00	22	15.8	10.5	11.57	13.55	16.1	13.1	13.1	11.5	15.6	16.6	14.2	32.0	28.4	37.4	33.4
△ FH52K-24S-0.5SH	CL580-4633-0-00	24	16.3	11.5	12.57	14.55	17.1	14.1	14.1	12.5	16.6	17.6	14.2	32.0	28.4	37.4	33.4
△ FH52K-25S-0.5SH	CL580-4634-0-00	25	16.8	12.0	13.07	15.05	17.6	14.6	14.6	13.0	17.1	18.1	14.2	32.0	28.4	37.4	33.4
△ FH52K-26S-0.5SH	CL580-4635-0-00	26	17.3	12.5	13.57	15.55	18.1	15.1	15.1	13.5	17.6	18.6	14.2	32.0	28.4	37.4	33.4
△ FH52K-30S-0.5SH	CL580-4631-0-00	30	19.3	14.5	15.57	17.55	20.1	17.1	17.1	15.5	19.6	20.6	20.2	44.0	40.4	49.4	45.4
△ FH52K-32S-0.5SH	CL580-4600-9-00	32	20.3	15.5	16.57	18.55	21.1	18.1	18.1	16.5	20.6	21.6	20.2	44.0	40.4	49.4	45.4
△ FH52K-34S-0.5SH	CL580-4601-0-00	34	21.3	16.5	17.57	19.55	22.1	19.1	19.1	17.5	21.6	22.6	20.2	44.0	40.4	49.4	45.4
△ FH52K-40S-0.5SH	CL580-4620-0-00	40	24.3	19.5	20.57	22.55	25.1	22.1	22.1	20.5	24.6	25.6	20.2	44.0	40.4	49.4	45.4
△ FH52K-45S-0.5SH	CL580-4637-0-00	45	26.8	22.0	23.07	25.05	27.6	24.6	24.6	23.0	27.1	28.1	20.2	44.0	40.4	49.4	45.4
△ FH52K-50S-0.5SH	CL580-4609-0-00	50	29.3	24.5	25.57	27.55	30.1	27.1	27.1	25.5	29.6	30.6	20.2	44.0	40.4	49.4	45.4
△ FH52K-60S-0.5SH	—————	60	34.3	29.5	30.57	32.55	35.1	32.1	32.1	30.5	34.6	35.6	26.2	56.0	52.4	61.4	57.4
△ FH52K-64S-0.5SH	—————	64	36.3	31.5	32.57	34.55	37.1	34.1	34.1	32.5	36.6	37.6	26.2	56.0	52.4	61.4	57.4
△ FH52K-68S-0.5SH	CL580-4614-0-00	68	38.3	33.5	34.57	36.55	39.1	36.1	36.1	34.5	38.6	39.6	26.2	56.0	52.4	61.4	57.4

※CONTACT POSITIONS WITHOUT CODE NUMBERS ARE CURRENTLY UNDER PLANNING.  
 PLEASE CONTACT HIROSE FOR DETAILED INFORMATION ABOUT PRODUCT VARIATION.

<b>HRS</b>	DRAWING NO.	EDC-365730-00-01
	PART NO.	FH52K-***S-0.5SH
	CODE NO.	CL580
		△ 4/8

Jul.1.2020 Copyright 2020 HIROSE ELECTRIC CO., LTD. All Rights Reserved.  
In case of consideration for using Automotive equipment / device which demand high reliability, kindly contact our sales window correspondents.

This connector requires delicate and careful handling.  
Read through the instructions shown below and handle the connector properly.  
Each values indicating here are for reference and may differ from standard value.

[Connector Part Nomenclature]

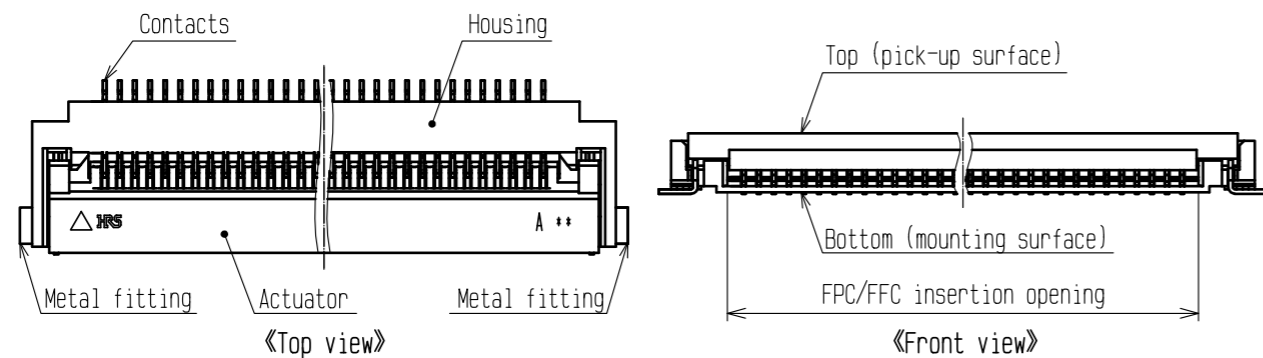

[Operation and Precautions]

1. Initial condition

The connector is delivered with the actuator closed.

[Caution]

-Do not insert FPC/FFC or operate actuator before mounting.

2. How to unlock (Before inserting FPC/FFC)

The actuator rotates on its axis as shown below.  
Slowly flip up the actuator to release the lock. (example 1)

[Caution]

- When operating the actuator do not apply any force in the direction of the connector. (example 2)
- Open the actuator by carefully lifting it at the center. (example 3)
- Do not lift the actuator at one end only. (example 4)
- The actuator must be operated by hand only, and do not insert any tools or fingernails inside the connector. (example 5.6)
- The actuator rotates 110 degrees max. Do not attempt to force the actuator to backside further. (example 7)
- Do not attempt to dislodge the actuator. (example 8.9)

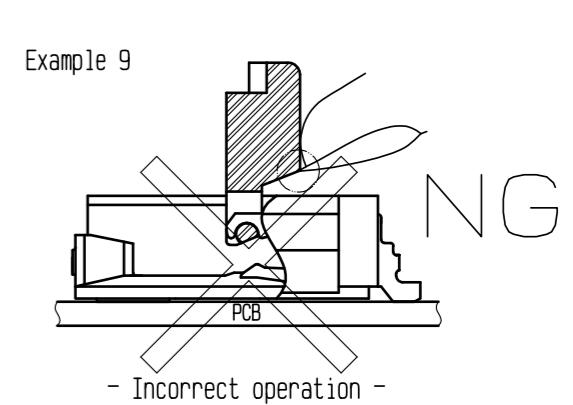
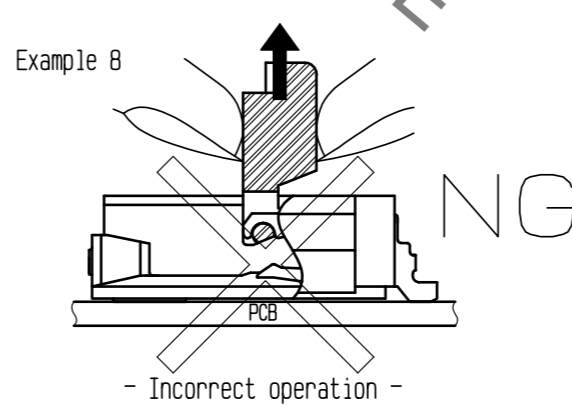
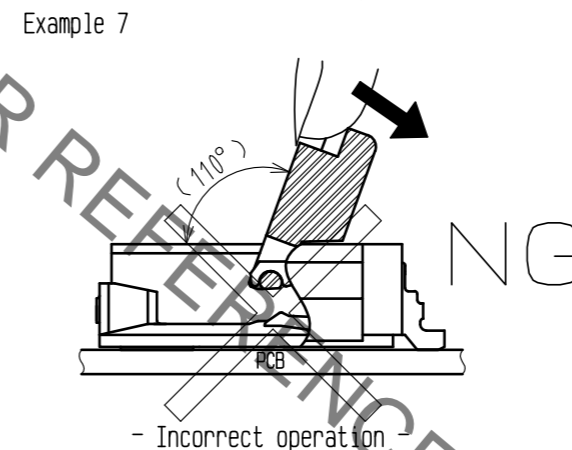
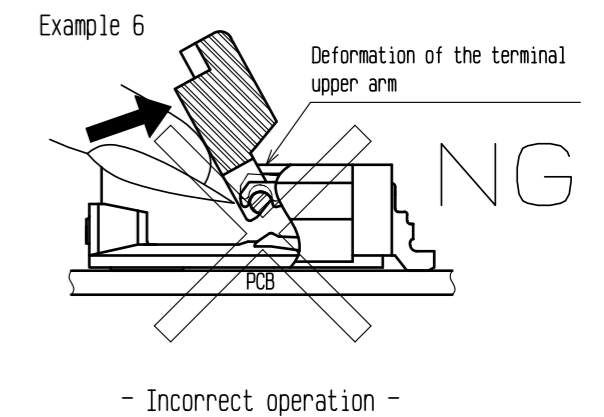
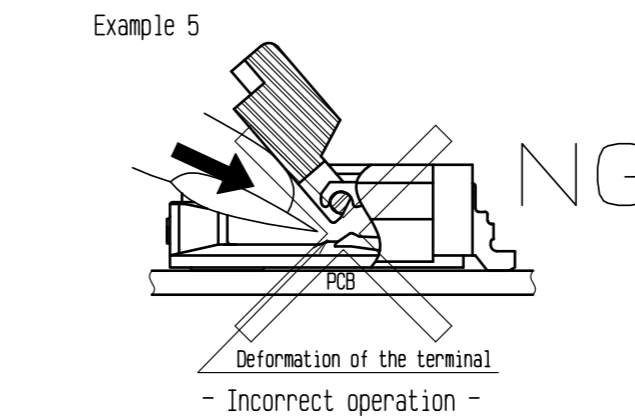
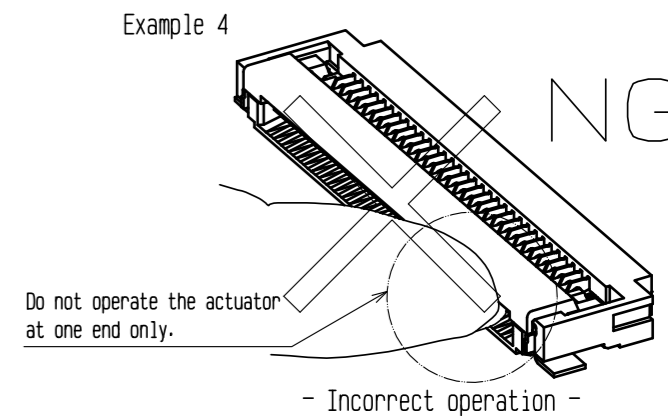
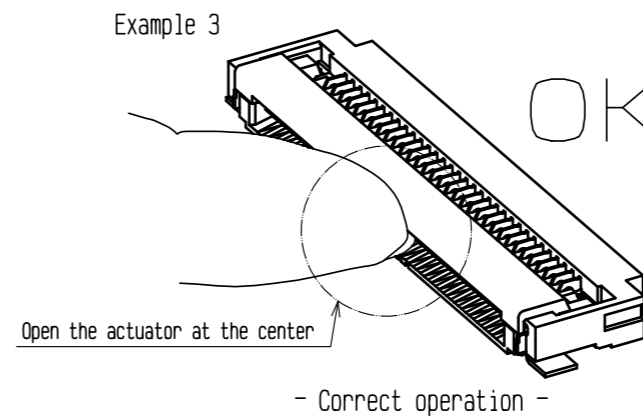
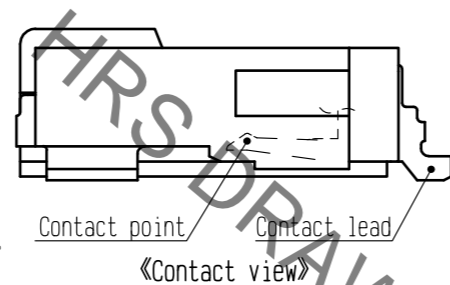
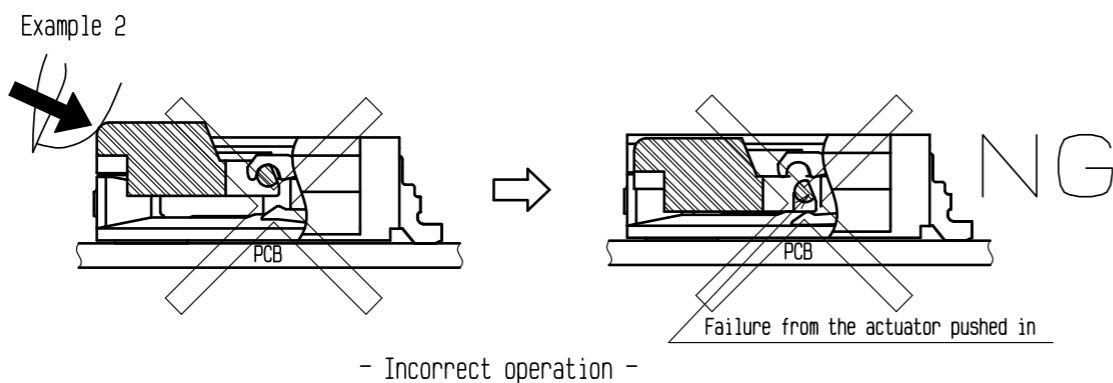
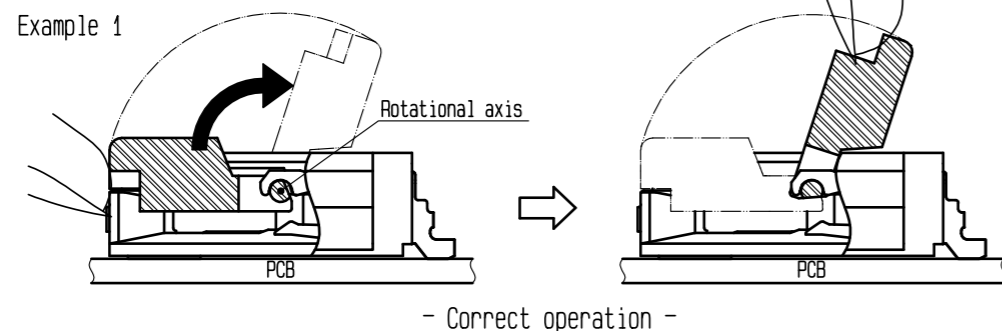

<INSTRUCTION MANUAL (1)>

<b>HRS</b>	DRAWING NO.	EDC-365730-00-01
	PART NO.	FH52K-**-0.5SH
	CODE NO.	CL580
		5/8

Jul.1.2020 Copyright 2020 HIROSE ELECTRIC CO., LTD. All Rights Reserved.  
 In case of consideration for using Automotive equipment / device which demand high reliability, kindly contact our sales window correspondents.

### 3. How to insert FPC/FFC

This connector has contacts on the bottom, insert the FPC/FFC with the exposed conductors face down.  
 This connector has Guide for positioning FPC/FFC, insert the FPC at about 10 degree angle to the PCB mounting surface. (example 10)  
 In case of using FPC/FFC without tabs, insert the FPC/FFC horizontally along the surface.

**[Caution]**

- Do not insert the FPC/FFC with the conductor surface face up.
- Insert the FPC/FFC properly to the very end.
- Do not insert the FPC/FFC at an angle. (example 11)
- Insert the FPC/FFC with the actuator opened. (example 12)
- Do not twist the FPC/FFC to up and down, right and left or an angle. (example 13)

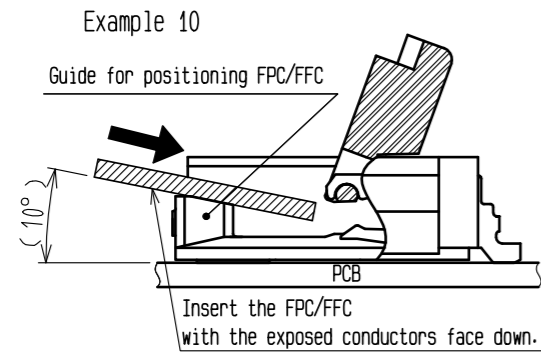

- Correct operation -

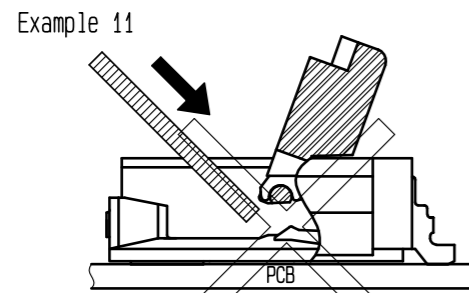

- Incorrect operation -

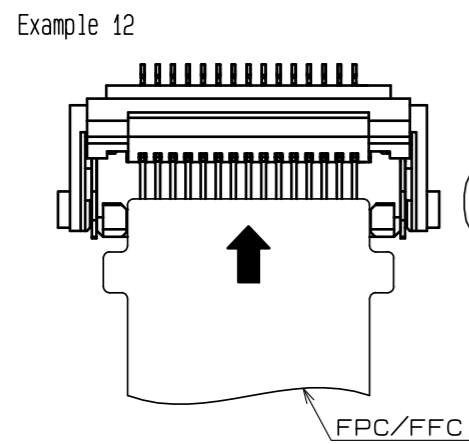

- Correct operation -

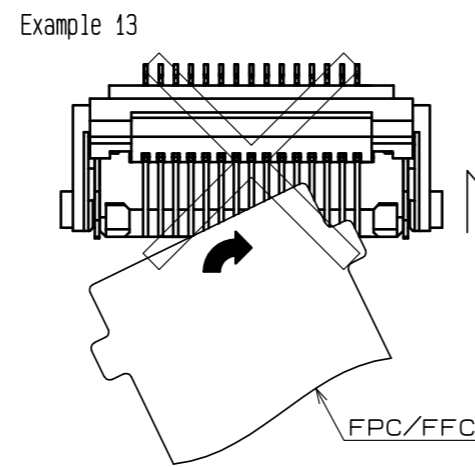

- Incorrect operation -

### 4. FPC/FFC insertion check

Guide for positioning FPC/FFC guide the FPC/FFC tabs to the correct position.  
 Make sure that the FPC/FFC tabs are located in correct position as shown in the figure below after FPC/FFC insertion. (example 14)

**[Caution]**

- Do not insert the FPC/FFC at an angle and/or stop it before insertion is completed. (example 15, 16)

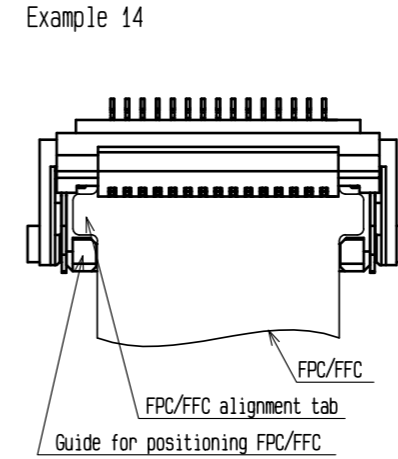

- Correct operation -

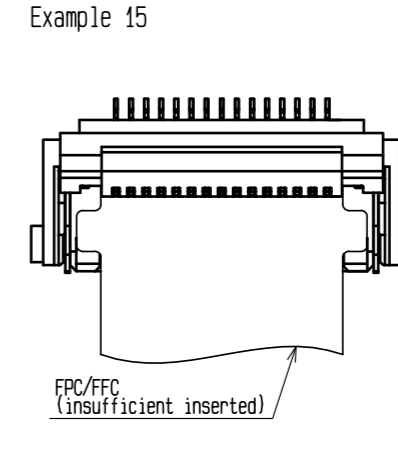

- Incorrect operation -

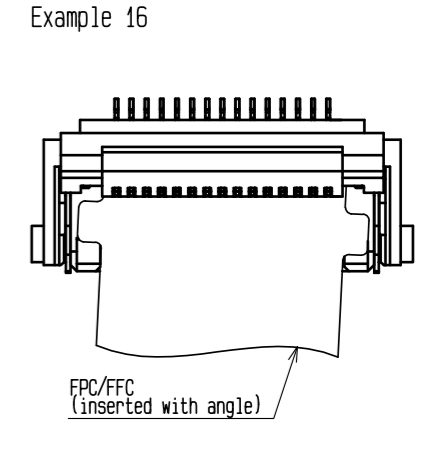

- Incorrect operation -

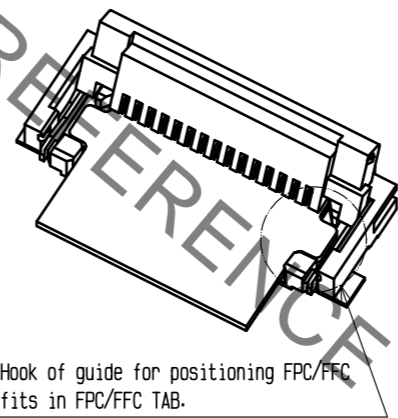

OK

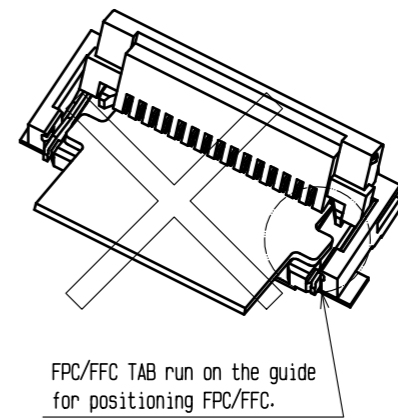

NG

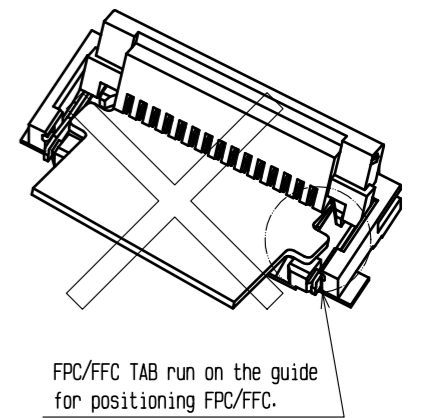

NG

<INSTRUCTION MANUAL (2)>

<b>HRS</b>	DRAWING NO.	EDC-365730-00-01
	PART NO.	FH52K-***S-0.5SH
	CODE NO.	CL580

Jul.1.2020 Copyright 2020 HIROSE ELECTRIC CO., LTD. All Rights Reserved.  
In case of consideration for using Automotive equipment / device which demand high reliability, kindly contact our sales window correspondents.

### 5. How to lock

The actuator rotates on its axis as shown below.  
Apply load to rotate the actuator after inserting the FPC/FFC. (example 17)

#### [Caution]

- Close the actuator by carefully operating it at the center. (example 18)
- Do not operate the actuator at one end only. (example 19)
- The actuator must be operated by hand only, and do not insert any tools or fingernails inside the connector.
- Do not attempt to force the actuator to backside further.
- When operating the actuator do not apply any force in the direction of the connector.
- Do not attempt to dislodge the actuator.
- Confirm that the actuator completely closed and is parallel to the PCB mounting surface.

Example 17

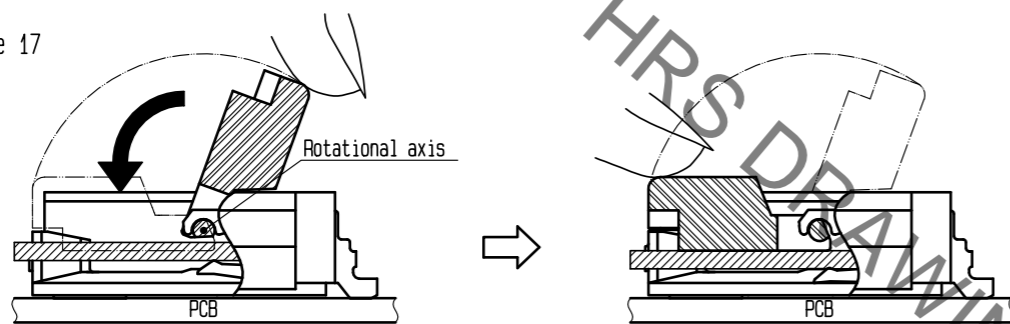

- Correct operation -

Example 18

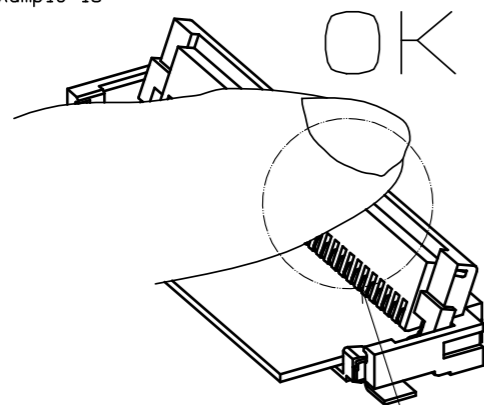

- Correct operation -

Example 19

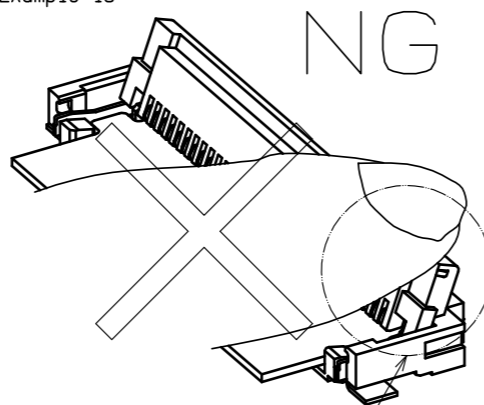

- Incorrect operation -

### 6. Mating confirmation of the FPC/FFC

In the locked condition, make sure that the actuator is horizontal on the board surface.  
Do not apply excessive force to it near the 0° position of the actuator.  
Otherwise, the terminals may be deformed.

### 7. How to unlock

Slowly flip up the actuator to release the lock. (example 20)

#### [Caution]

- Open the actuator by carefully lifting it at the center. (example 21)
- Do not lift the actuator at one end only. (example 22)
- When operating the actuator do not apply any force in the direction of the connector.
- The actuator must be operated by hand only, and do not insert any tools or fingernails inside the connector.
- The actuator rotates 110 degrees max. Do not attempt to force the actuator to backside further. (example 23)
- Do not attempt to dislodge the actuator. (example 24)

Example 20

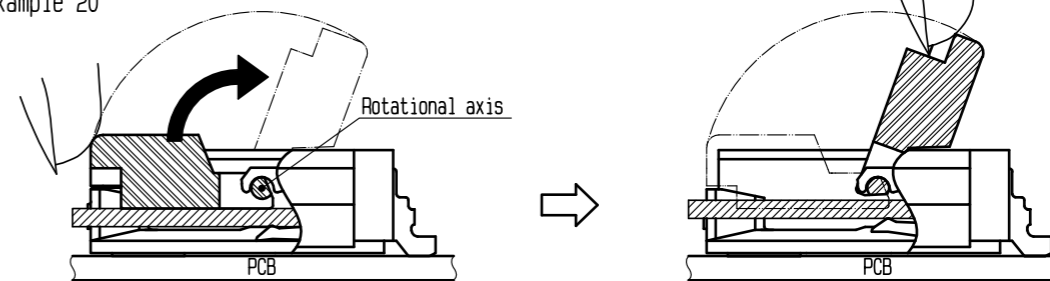

- Correct operation -

Example 21

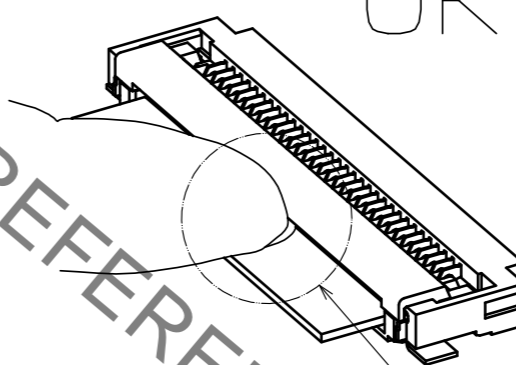

Close the actuator at the center

- Correct operation -

Example 22

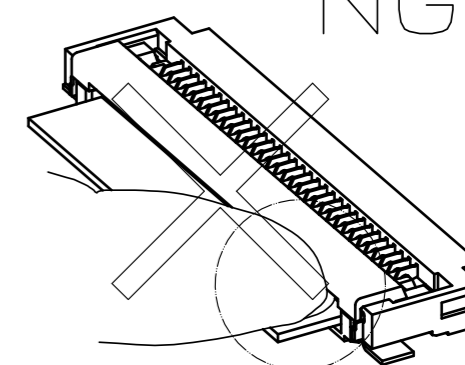

Do not operate the actuator at one end only

- Incorrect operation -

Example 23

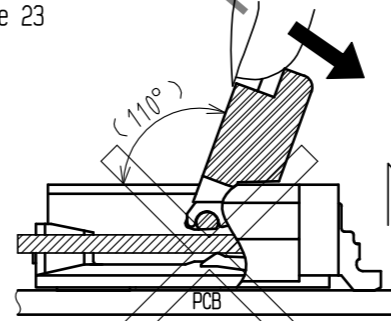

- Incorrect operation -

Example 24

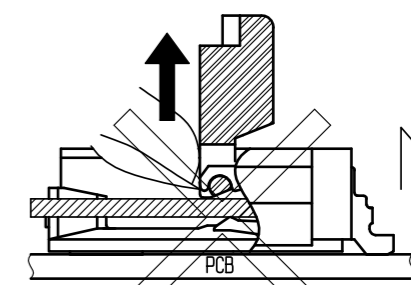

- Incorrect operation -

<INSTRUCTION MANUAL (3)>

<b>HRS</b>	DRAWING NO.	EDC-365730-00-01
	PART NO.	FH52K-***S-0.5SH
	CODE NO.	CL580
		7/8

Jul.1.2020 Copyright 2020 HIROSE ELECTRIC CO., LTD. All Rights Reserved.  
In case of consideration for using Automotive equipment / device which demand high reliability, kindly contact our sales window correspondents.

B. How to remove FPC/FFC

This connector has a temporary FPC/FFC holding structure with guide for positioning FPC/FFC. After rotating the actuator to the fully opened position carefully withdraw the FPC/FFC pulling out at about 10 degree angle to the PCB mounting surface. (example 25)  
In case of using FPC/FFC without tabs, pull out the FPC/FFC horizontally along the surface.

[Caution]

- For FPC/FFC removal, do not pull out the FPC/FFC horizontally.
- Do not withdraw the FPC/FFC at an angle. (example 26)
- Do not attempt to pull the FPC/FFC without unlocking the actuator. (example 27)

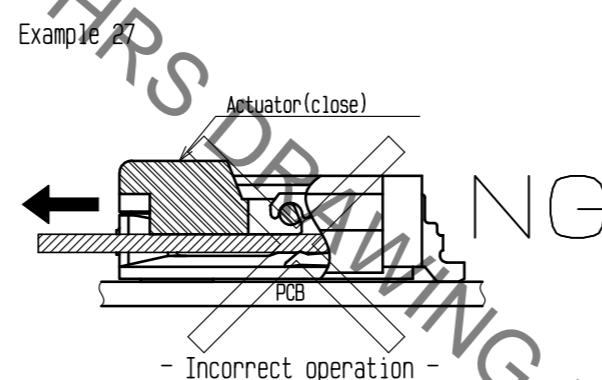
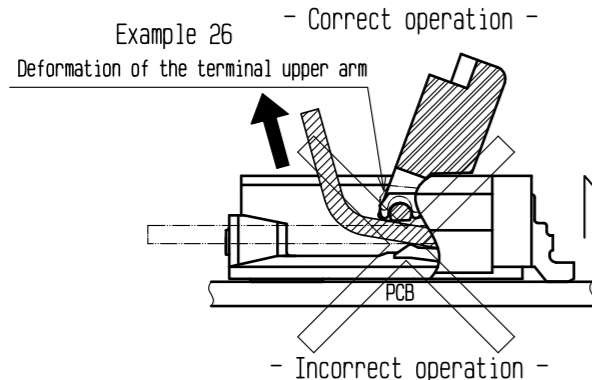
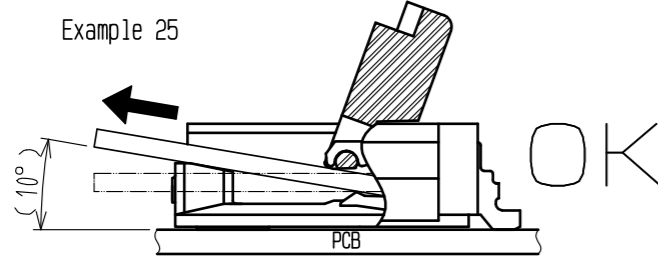

[Precautions for component layout]

Depending on a FPC/FFC rounding, a load is applied to the connector, and a contact failure may occur. To prevent a failure, take the following notes into a consideration during mechanism design.

[Caution]

- Avoid applying forces to FPC/FFC in vertical or horizontal directions. (example 28)
- In addition, avoid pulling up and down on the FPC/FFC.
- When fixing FPC/FFC after FPC/FFC cabling, avoid pulling FPC/FFC, and route the wire FPC/FFC with slack. In this regard, the stiffener is parallel to the PCB. (example 29)
- Do not bend the FPC/FFC excessively near the connector during use, or it may cause contact failure or FPC/FFC breakage. (example 30)
- Fixing the FPC/FFC is recommended to prevent these failures.
- Do not mount other components touching to the FPC/FFC underneath the FPC/FFC stiffener. (example 31)
- Follow the recommended FPC/FFC design.
- Make adjustments with the FPC/FFC manufacturer for FPC/FFC bending performance and wire breakage.
- Keep a sufficient FPC/FFC insertion space in the stage of the layout in order to avoid incorrect FPC/FFC insertion.
- Appropriate FPC/FFC length and component layout are recommended for assembly ease.
- Too short FPC/FFC length makes assembly difficult.
- Keep spaces for the actuator movement and its operation for PCB design and component layout.

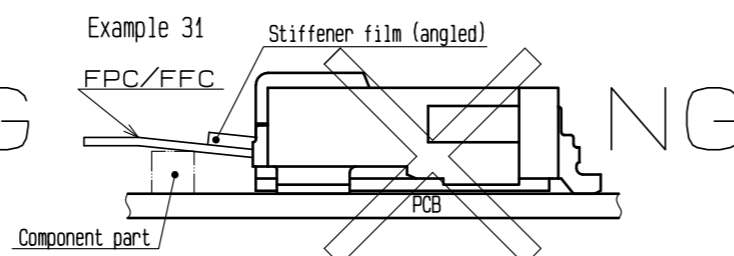
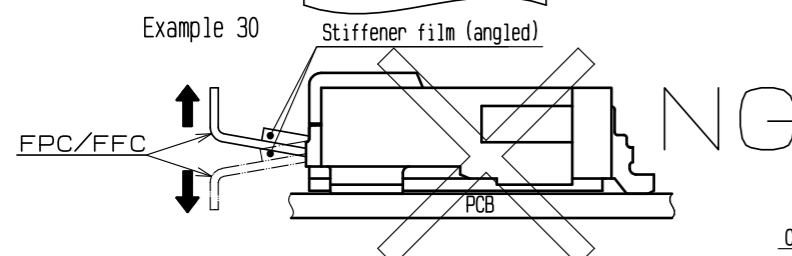
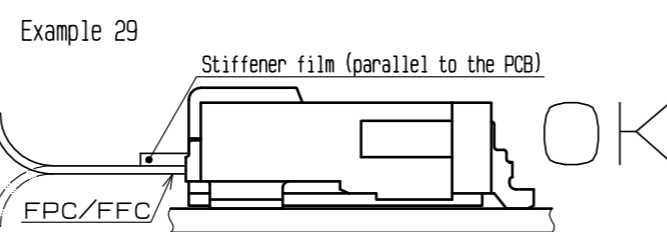
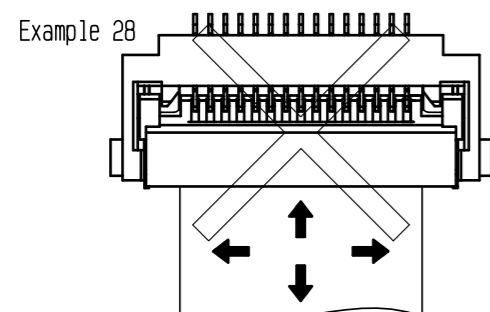

[Instructions for mounting on the PCB]

Follow the instructions shown below when mounting on the PCB.

[Caution]

- Refer to recommended layouts on the page 1 for PCB and stencil pattern.
- Shorter pattern width than the recommended PCB dimension, could cause solder wicking and/or flux penetration.
- Larger pattern than the recommended stencil dimension, could cause solder wicking and/or flux penetration.
- Clearance underneath the contact and the housing is very small. In case solder resist and/or silk screening are applied on PCB underneath the connector, verify the thickness, or it could push up the connector bottom and may cause soldering defect and/or insufficient fillet formation.
- Apply reflow temperature profile within the specified conditions. In individual applications, the actual temperature may vary, depending on solder paste type, volume/thickness and PCB size/thickness. Consult your solder paste and equipment manufacturer for specific recommendations.
- Prevent warpage of PCB, where possible, since it can cause soldering failure; even with 0.1 mm max coplanarity.
- When mounting on the flexible board, please make sure to put a stiffener on the backside of the flexible board. We recommend a glass epoxy material with the thickness of 0.3 mm MIN.
- Do not add 1 N or greater external force when unreel or pick and place the connector etc, or it may get broken.

[Instructions for PCB handling after mounting the connector]

Follow the instructions shown below when mounting on the PCB.

[Caution]

- Splitting a large PCB into several pieces
  - Screwing the PCB
- Avoid the handling described above so that no force is exerted on the PCB during the assembly process. Otherwise, the connector may become defective.
- The warp of a 100 mm wide PCB should be 0.5 mm or less. (example 32)
  - The warp of PCB suffers stress on connector and the connector may become defective.

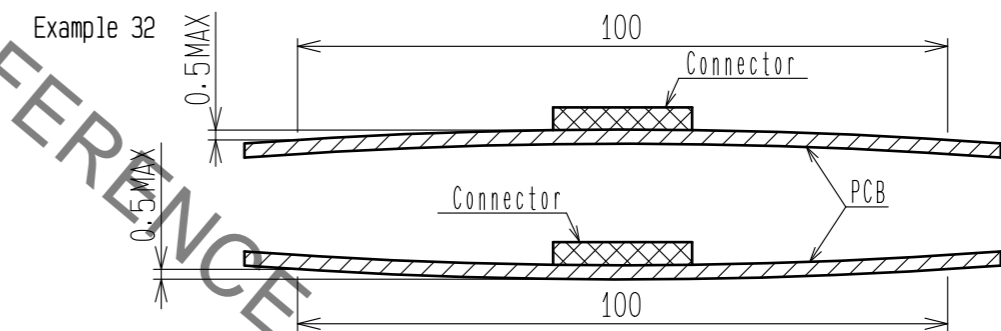

[Instructions on manual soldering]

Follow the instructions shown below when soldering the connector manually during repair work, etc.

[Caution]

- Do not perform manual soldering with the FPC/FFC inserted into the connector.
  - Do not heat the connector excessively. Be very careful not to let the soldering iron contact any parts other than connector leads. Otherwise, the connector may be deformed or melt.
  - Do not supply excessive solder (or flux).
- If excessive solder (or flux) is supplied on the terminals, solder or flux may adhere to the contacts or rotating parts of the actuator, resulting in poor contact or a rotation failure of the actuator. Supplying excessive solder to the metal fittings may hinder actuator rotation, resulting in breakage of the connector.

<INSTRUCTION MANUAL (4)>

<b>HRS</b>	DRAWING NO.	EDC-365730-00-01	8/8
	PART NO.	FH52K-***S-0.5SH	
	CODE NO.	CL580	