

REVISIONS					
REV	ECO	DESCRIPTION	DATE	BY	APPR
A1	-	RESEAL NEW DRAWING	12MAY20	IAN	TOMMY
A2	-	MODIFY PRODUCT NAME	11AUG20	IAN	TOMMY

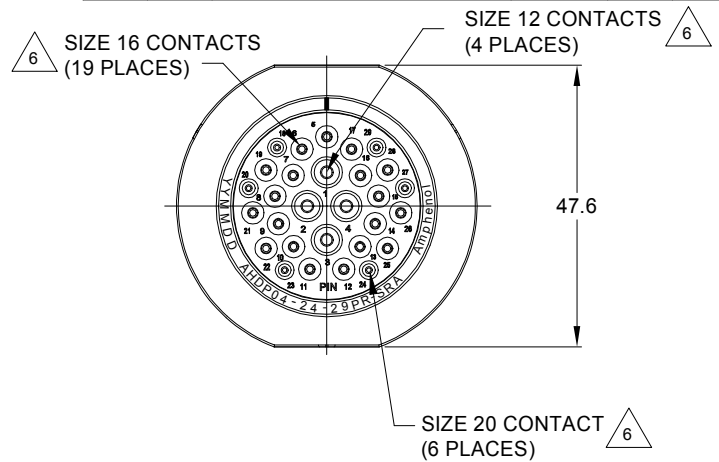

NOTES: UNLESS OTHERWISE SPECIFIED

- MATERIAL:
HOUSING: THERMOPLASTIC; BLACK
SEAL: SILICONE RUBBER
- MODIFICATIONS: SMOOTH RING ADAPTOR (SRA);
REDUCED DIA. WIRE SEAL
- SPECIFICATIONS:
 - OPERATING TEMPERATURE: -55°C TO +125°C.
 - DIELECTRIC WITHSTANDING VOLTAGE: LESS THAN 2 MILLIAMPS CURRENT LEAKAGE @ 1500 VOLTS AC.
 - INSULATION RESISTANCE: 1000 MEGOHM MIN @ 25°C.
 - MOISTURE RESISTANCE: IP67&IP69K (MATED CONDITION).
 - MATING CYCLE DURABILITY: 100 CYCLES
 - RoHS COMPLIANT
- MATING PART: AHDP06-24-29S* (* = SEAL TYPE)
- ALL DIMENSIONS ARE FOR REFERENCE USE ONLY.

6 CONTACT SIZE AND WIRE RANGE:

CONTACT SIZE	MIN. INSUL O.D.	MAX. INSUL O.D.	TYPICAL WIRE RANGE	CURRENT RATING
20	1.02 mm (.040 in)	2.10 mm (.083 in)	16-22 AWG (1.5-0.5mm ²)	7.5 AMPS
16	1.35 mm (.053in)	2.62 mm (.103 in)	14-20 AWG (2.0-0.5mm ²)	13 AMPS
12	2.46 mm (.097 in)	4.01 mm (.158 in)	10-14 AWG (6.0-2.0mm ²)	25 AMPS

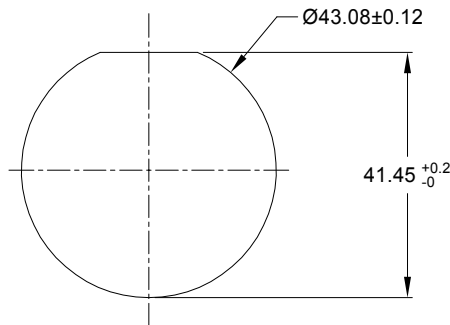

RECOMMENDED PANEL MOUNTING HOLE

RECOMMENDED PANEL THICKNESS: 1.6 TO 4.7MM

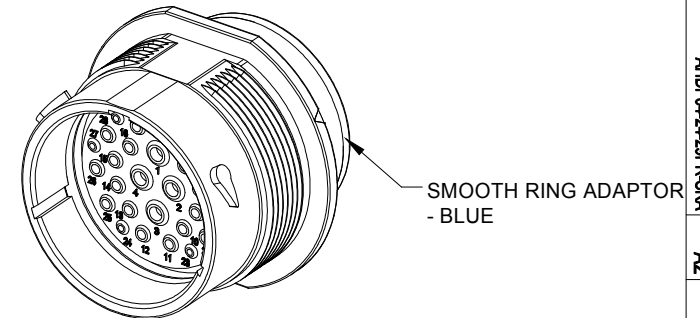

AHPD04-24-29PR-SRA		REF: HDP24-29PE	
PART NUMBER		DESCRIPTION	
QUANTITY		MATERIALS LIST	
UNLESS OTHERWISE SPECIFIED		SIGNATURES	
1) All dimensions are in metric(mm).		DATE	
2) Tolerances are as follows:		DRAWN: WANXIAO 11AUG20	
1 PL DEC ±0.30		CHECKED: ORIONLI 12AUG20	
2 PL DEC ±0.15		ENGINEER:	
3 PL DEC ±0.08		APPROVAL: TOMMYXIE 13AUG20	
3) Note reference =		CUSTOMER:	
MATERIAL SPECIFICATIONS:		THIS DRAWING IS SUPPLIED FOR INFORMATION ONLY. DESIGN FEATURES, SPECIFICATIONS AND PERFORMANCE DATA SHOWN HEREON ARE THE PROPERTY OF THE AMPHENOL CORPORATION. NO RIGHTS OF REPRODUCTION ARE IMPLIED. ALL DIMENSIONS ARE SUBJECT TO NORMAL MANUFACTURING VARIATIONS.	
PROCESS SPECIFICATIONS:		SCALE: NONE	
NEXT ASSY:		DURAMATE	

Amphenol

Sine Systems - www.amphenol-sine.com
44724 Morley Drive
Clinton Township, MI 48036

RECEPT, SIZE 24, 29-PIN, RD01 SEAL, SRA, DURAMATE AHDP SEIRES

SIZE: **B C-** TYPE: **AHDP04-24-29PR-SRA** DWG NO: **A2** REVISION

SCALE: NONE DURAMATE SHEET 1 OF 1

7. RECEPTACLE IS SUPPLIED WITH DUST CAP.

TITLE: RECEPT, SIZE 24, 29-PIN, RD01 SEAL, SRA, DURAMATE AHDP SEIRES
DWG NO: AHPD04-24-29PR-SRA
REV: A2
SH: 1
OF: 1