

REVISIONS					
REV	ECO	DESCRIPTION	DATE	BY	APPR
A1	--	RELEASED	16MAR2020	J. HEAD	DH

NOTES: UNLESS OTHERWISE SPECIFIED

- RECEPTACLE MATERIAL:  
SHELL: ZINC ALLOY, NICKEL PLATED  
INSERT AND RETAINING RING: THERMOPLASTIC  
SEAL: SILICONE RUBBER
- BACKSHELL MATERIAL:  
SHELL: ALUMINIUM ALLOY, NICKEL PLATED;  
LATCH SEGMENT: ALUMINIUM ALLOY, NICKEL PLATED;  
SCREW AND LOCK WASHER: STAINLESS STEEL;  
BUSHING: EPDM.
- SPECIFICATIONS:
  - OPERATING TEMPERATURE: -55°C TO +125°C.
  - DIELECTRIC WITHSTANDING VOLTAGE: LESS THAN 2 MILLIAMPS CURRENT LEAKAGE @ 1500 VOLTS AC.
  - INSULATION RESISTANCE: 1000 MEGOHM MIN @ 25°C.
  - MOISTURE RESISTANCE: IP67 & IP69K (MATED CONDITION).
  - MATING CYCLE DURABILITY: 100 CYCLES
  - RoHS COMPLIANT
- APPLY BACKSHELL TO CABLE OD SIZE:  $\varnothing 11.20$ - $\varnothing 19.30$  . CAN BE USED WITH OR WITHOUT BUSHING.
- ALL DIMENSIONS ARE FOR REFERENCE USE ONLY.
- SEE SPECIFIC RECEPTACLE DRAWING FOR:
  - CONTACT SIZE AND WIRE RANGE.
  - RETAINING RING COLOR.
  - MATING PART(S).
  - CONTACT LAYOUT AND ALL OTHER SPECIFICATIONS.

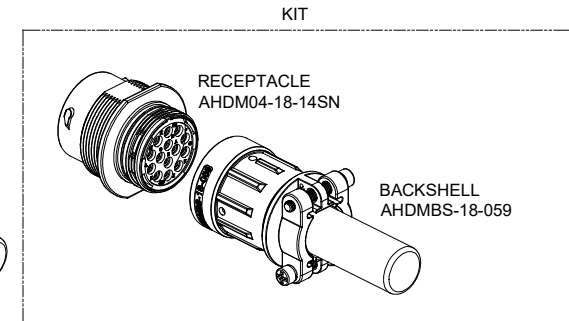
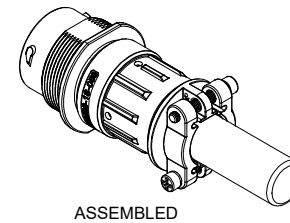

AHD04-18-14SN-059		HD34-18-14SN-059	
PART NUMBER		DESCRIPTION	
QUANTITY		ITEM	
<b>MATERIALS LIST</b>			
UNLESS OTHERWISE SPECIFIED			
1) All dimensions are in metric (mm).			
2) Tolerances are as follows:			
1 PL DEC $\pm 0.30$	Fractions $\pm 1/64$		
2 PL DEC $\pm 0.15$	Angles $\pm 1^\circ$		
3 PL DEC $\pm 0.08$			
3) Note reference =			
SIGNATURES		DATE	
DRAWN: J. HEAD		16MAR2020	
CHECKED:			
ENGINEER:			
APPROVAL:			
MATERIAL SPECIFICATIONS:		CUSTOMER:	
PROCESS SPECIFICATIONS:		THIS DRAWING IS SUPPLIED FOR INFORMATION ONLY. DESIGN FEATURES, SPECIFICATIONS AND PERFORMANCE DATA SHOWN HEREON ARE THE PROPERTY OF THE AMPHENOL CORPORATION. NO RIGHTS OF REPRODUCTION ARE IMPLIED. ALL DIMENSIONS ARE SUBJECT TO NORMAL MANUFACTURING VARIATIONS.	
NEXT ASSY:		SCALE: NONE	
		SHEET 1 OF 1	

**Amphenol**

Sine Systems - www.amphenol-sine.com  
44724 Morley Drive  
Clinton Township, MI 48036

DURAMATE AHDM RECEPT, SIZE 18, WD THD,  
KIT W/ CABLE CLAMP BACKSHELL

SIZE: B TYPE: C- DWG NO: AHDM04-18-14SN-059 REVISION: A1

TITLE: KIT, RECEPT AND BACKSHELL, SZ 18  
DWG NO: AHD04-18-14SN-059  
REV: A1  
SH: 1  
OF: 1