

DRAWING NO	SHEET	MODEL NAME	ISSUE
SPL8192	1 OF 3	NA	1

ISSUE	MODIFICATION	DRN	DATE
1	ORIGINAL ISSUE	NJK	17.08.07



Marl International Limited
 Marl Business Park,
 Ulverston, Cumbria,
 LA12 9BN, England.

tel: +44 (0)1229 582430
 fax: +44 (0)1229 585155
 e-mail: sales@marl.co.uk
 website: www.marl.co.uk

WIRING SCHEMATICS FOR ARCHITECTURAL LIGHTING

Overview

An LED light fixture requires a constant current power source. To facilitate the smooth installation of the LED fixtures available in the Solid State Lighting catalogue, a comprehensive range of constant current drivers are provided. Driver configurations can be tailored to match individual application requirements. Below is a brief explanation of each driver configuration including components required.

A - Low voltage non-dimmable 1 way

This system is used to power one white LED light fixture. The components required are as follows:
 Low voltage power supply - LP1060 (see accessories data sheet)
 External driver box - 726 series driver box (see SPL8148)
 LED light fixture - See Solid State Lighting catalogue
 Optional extras:
 Junction box - JUNCTIONBOX5AMP (see accessories data sheet)
 IP68 junction box - SL001-2WAY (see accessories data sheet)

Installation notes:

1. Connect AC input cable of the LP1060 to mains power. Do not turn mains power on until installation is complete. A junction box may be required.
2. Connect the Class 2 power output cable of the LP1060 to the input of the external driver box. See SPL8148 for external driver box installation notes. A junction box may be required.
3. Connect LED light fixture to LED output of external driver box. See SPL8148 for external driver box installation notes. A junction box may be required.
4. Turn on mains power.

B - Low voltage non-dimmable 2 to 4 way

This system is used to power 2 to 4 white LED light fixture. The components required are as follows:
 Low voltage power supply - LP1060 (see accessories data sheet)
 External driver box - 726 series driver box (see SPL8148)
 LED light fixture - See Solid State Lighting catalogue
 Optional extras:
 Junction box - JUNCTIONBOX5AMP (see accessories data sheet)
 IP68 junction box - SL001-2WAY (see accessories data sheet)

Installation notes:

1. Connect AC input cable of the LP1060 to mains power. Do not turn mains power on until installation is complete. A junction box may be required.
2. Connect the Class 2 power output cable of the LP1060 to the input of the external driver box. See SPL8148 for external driver box installation notes. A junction box may be required.
3. Connect LED light fixture to LED output of external driver box. See SPL8148 for external driver box installation notes. A junction box may be required.
4. Repeat step 3 for each LED light fixture.
5. Turn on mains power.

A - Low Voltage Non-Dimmable 1 way

12V output for 3W, 6W, 8W product.

24V output for 25W product.

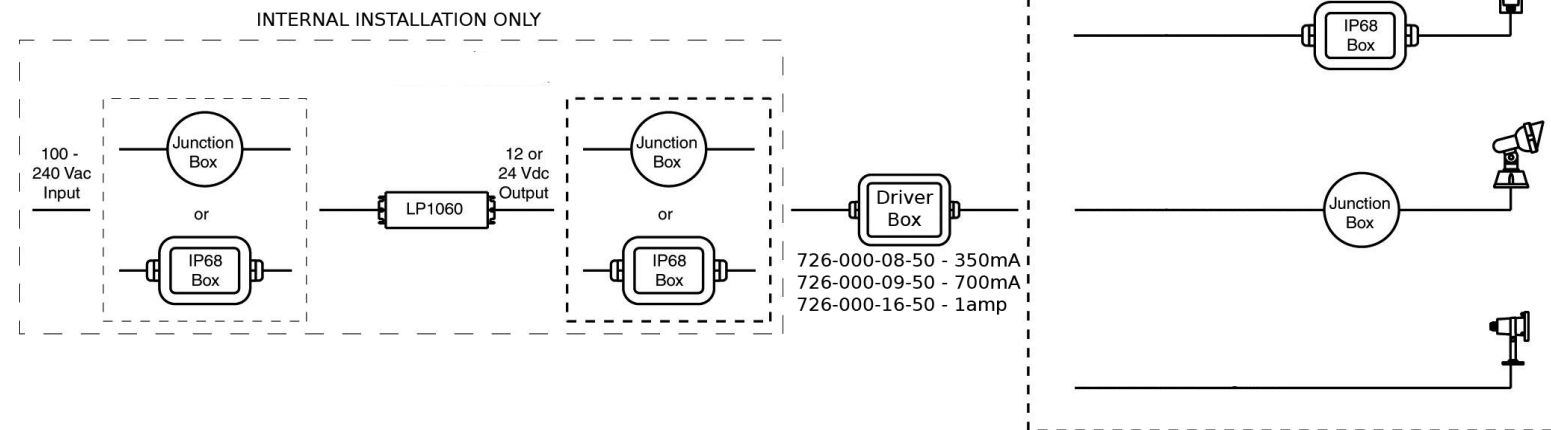

B - Low Voltage Non-Dimmable 2 to 4 way*

12V output for 3W, 6W, 8W product.

24V output for 25W product.

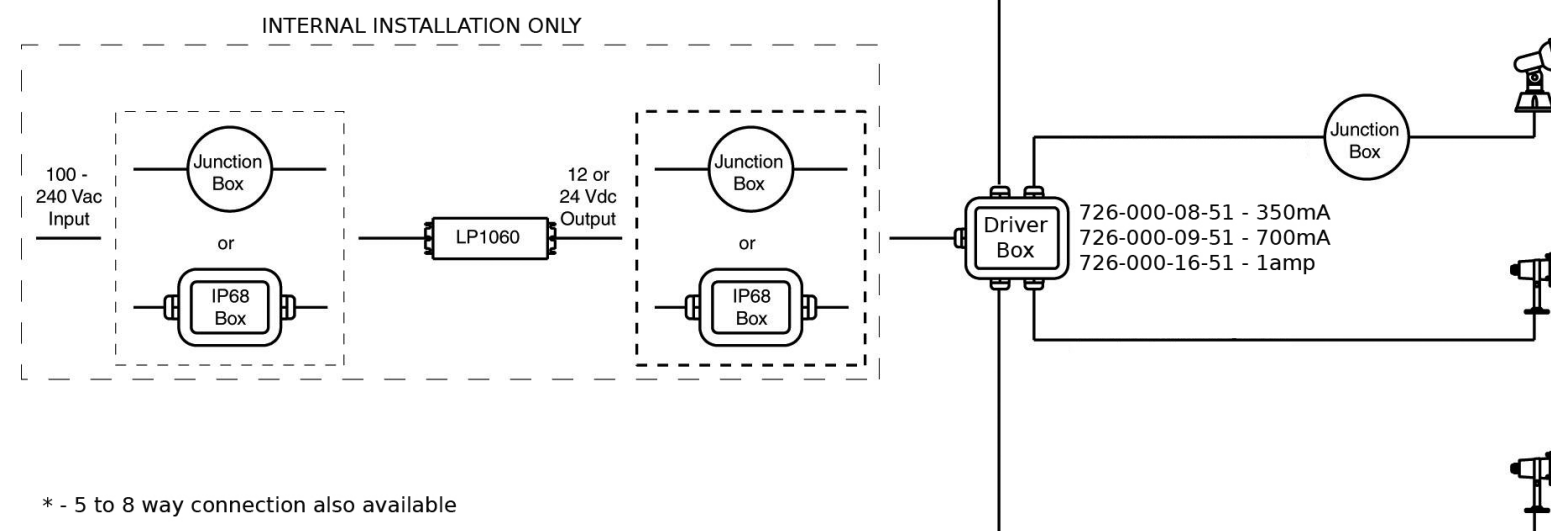

* - 5 to 8 way connection also available

TOLERANCE/ SCALE UOS		DRN:	NJK
LINEAR	N/A	DATE:	17/08/07
ANGULAR	N/A	CHK1:	<i>[Signature]</i>
ORIGINAL SCALE	1:1	CHK2:	<i>[Signature]</i>

DRAWING NO	SHEET	MODEL NAME	ISSUE
SPL8192	2 OF 3	NA	1

ISSUE	MODIFICATION	DRN	DATE
1	ORIGINAL ISSUE	NJK	17.08.07



Marl International Limited
 Marl Business Park,
 Ulverston, Cumbria,
 LA12 9BN, England.

tel: +44 (0)1229 582430
 fax: +44 (0)1229 585155
 e-mail: sales@marl.co.uk
 website: www.marl.co.uk

WIRING SCHEMATICS FOR ARCHITECTURAL LIGHTING

C - Low voltage dimmable 1 to 8 way

This system is used to power 1 to 8 white LED light fixture.
 The components required are as follows:
 Low voltage power supply - LP1060 (see accessories data sheet)
 Dimmable driver unit - 726 series dimmable driver unit (see accessories data sheet)
 LED light fixture - See Solid State Lighting catalogue
 Optional extras:
 Junction box - JUNCTIONBOX5AMP (see accessories data sheet)
 IP68 junction box - SL001-2WAY (see accessories data sheet)

Installation notes:

1. Connect AC input cable of the LP1060 to mains power. Do not turn mains power on until installation is complete. A junction box may be required.
2. Connect the Class 2 power output cable of the LP1060 to the input of the dimmable driver unit and the input of the 0-10V dimmer. See data sheet for dimmable driver unit. A junction box may be required.
3. Connect LED light fixture to LED output of dimmable driver unit. See data sheet for dimmable driver unit.
4. Connect the output for the 0 - 10V dimmer to the input of the dimmable driver unit. A junction box may be required.
5. Repeat step 3 and 4 for each LED light fixture.
6. Turn on mains power and adjust dimmer as required.

C - Low Voltage Dimmable 1 to 8 way

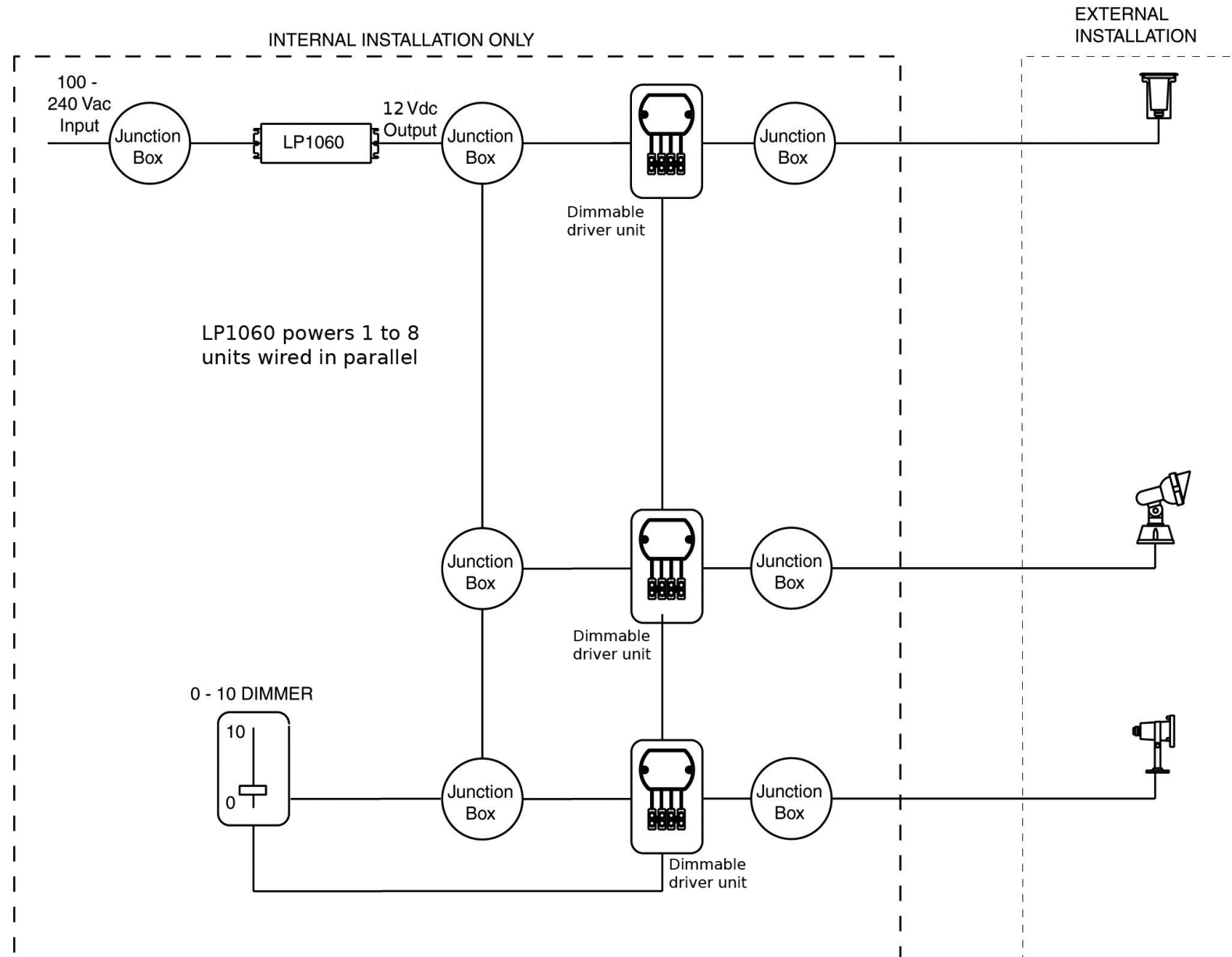

TOLERANCE/ SCALE UOS		DRN:	NJK
LINEAR	N/A	DATE:	17/08/07
ANGULAR	N/A	CHK1:	<i>[Signature]</i>
ORIGINAL SCALE	1:1	CHK2:	<i>[Signature]</i>

DRAWING NO	SHEET	MODEL NAME	ISSUE
SPL8192	3 OF 3	NA	1

ISSUE	MODIFICATION	DRN	DATE
1	ORIGINAL ISSUE	NJK	17.08.07



Marl International Limited
Marl Business Park,
Ulverston, Cumbria,
LA12 9BN, England.

tel: +44 (0)1229 582430
fax: +44 (0)1229 585155
e-mail: sales@marl.co.uk
website: www.marl.co.uk

WIRING SCHEMATICS FOR ARCHITECTURAL LIGHTING

D - Mains voltage non-dimmable 1 way

This system is used to power one white LED light fixture.

The components required are as follows:

Mains driver unit - L07U or LP1040 (see accessories data sheet)

LED light fixture - See Solid State Lighting catalogue

Optional extras:

Junction box - JUNCTIONBOX5AMP (see accessories data sheet)

IP68 junction box - SL001-2WAY (see accessories data sheet)

Installation notes:

1. Connect AC input leads of the L07U or LP1060 to mains power.

Do not turn mains power on until installation is complete. A junction box may be required.

2. Connect LED light fixture to LED output leads of mains driver unit. See L07U or LP1040 data sheet installation notes.

A junction box may be required.

3. Turn on mains power.

D - Mains Voltage Non-Dimmable 1 way

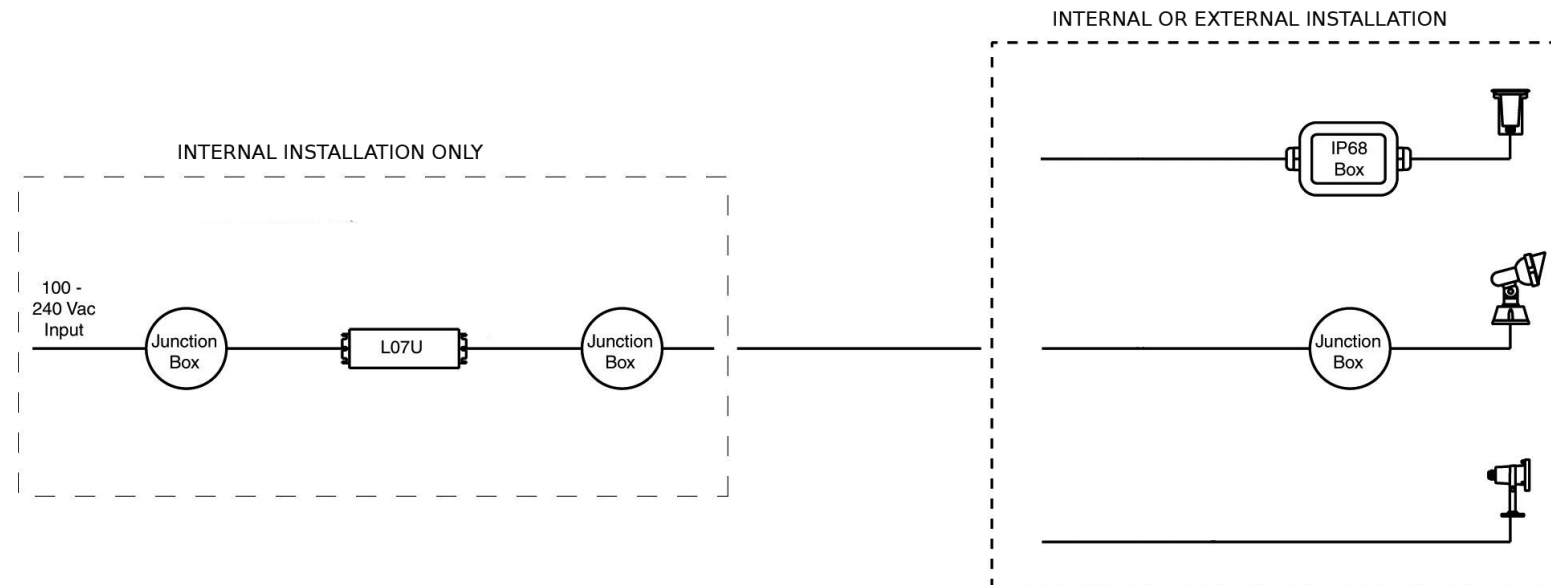

TOLERANCE/ SCALE UOS		DRN:	NJK
LINEAR	N/A	DATE:	17/08/07
ANGULAR	N/A	CHK1:	<i>D.H.</i>
ORIGINAL SCALE	1:1	CHK2:	<i>NJK</i>

