

REVISIONS				
ZONE	REV.	DESCRIPTION	DATE	APPROVED
	A	RELEASE	JRM 2/2/21	

**ALL DIMENSIONS ARE FOR REFERENCE ONLY**  
 DIMENSIONS ARE IN INCHES [MILLIMETERS]  
 UNLESS OTHERWISE NOTED

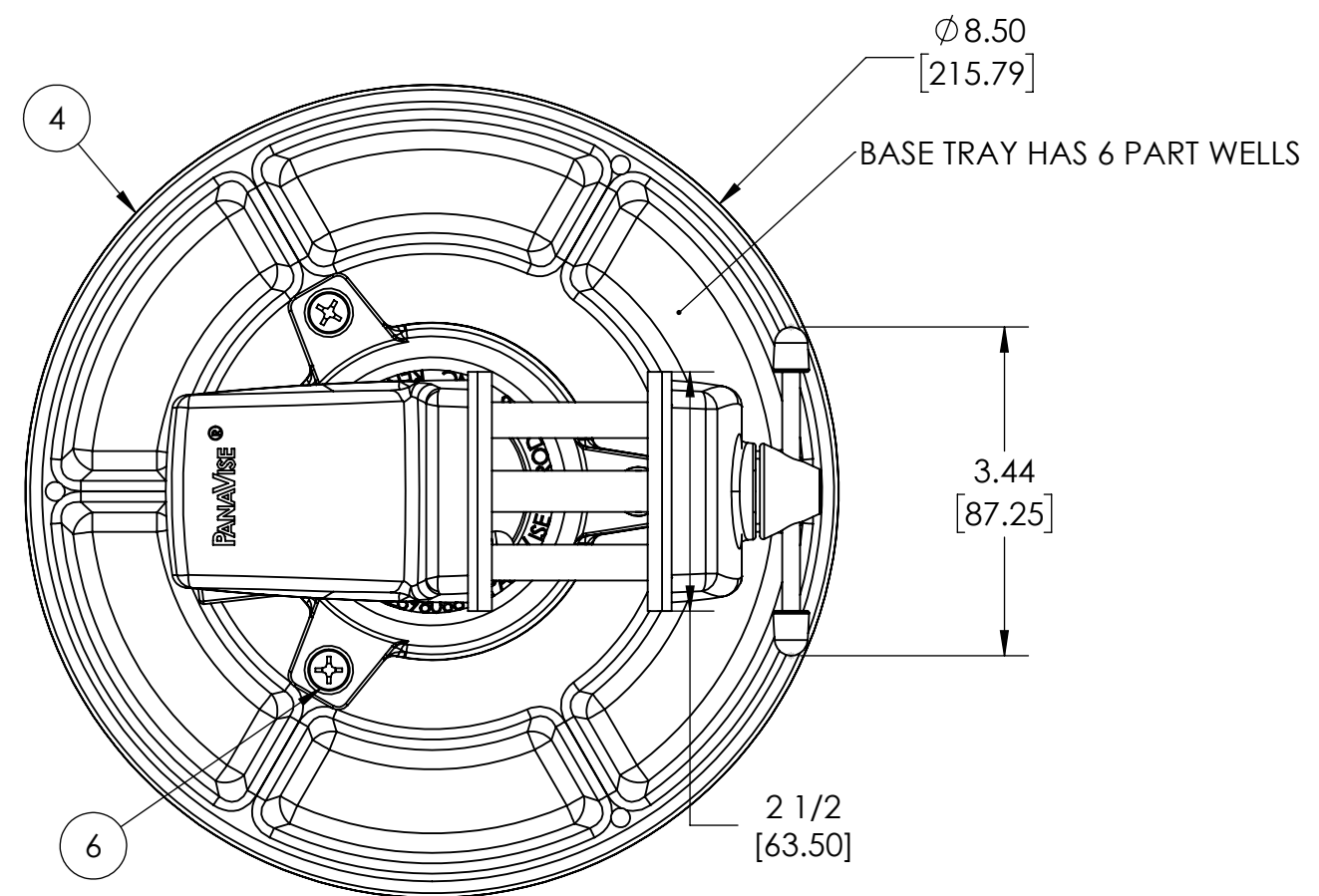

**SPECIFICATIONS**

- OVERALL HEIGHT..... 5.60 [142.29]
- ROTATION..... 360 DEGREES
- TURN..... 360 DEGREES
- TILT..... 90 DEGREES
- SHIPPING WEIGHT..... 5.25 LBS
- WISE OPENING..... 2 1/4 [57.15] MAXIMUM
- JAW WIDTH..... 2 1/2 [63.50]
- JAW HEIGHT..... 1/2 [12.70]

**MATERIAL:**

- 1. VISE HEAD ASSY\*..... 380 ALUMINUM DIE CASTING SILVER PAINT
- 2. BASE ASSY\*\*..... #3 ZINC DIE CAST SILVER PAINT
- 3. KNOB..... BLACK GLASS REINFORCED THERMAL COMPOSITE ALLOY
- 4. BASE TRAY..... #3 ZINC DIE CAST SILVER PAINT
- 5. BUMPON..... BLACK RUBBER
- 6. SCREW..... 1/4-20 X 1/2 PHILLIPS HEAD, STEEL

\*VISE HEAD ASSEMBLY INCLUDES ADJUSTING SCREW, GUIDE PINS, LEVER, LEVER ROD CAPS AND STEM.  
 \*\*BASE ASSEMBLY INCLUDES HALF BALL HOUSINGS, RETAINER RING, SCREWS, STUD AND NUT.

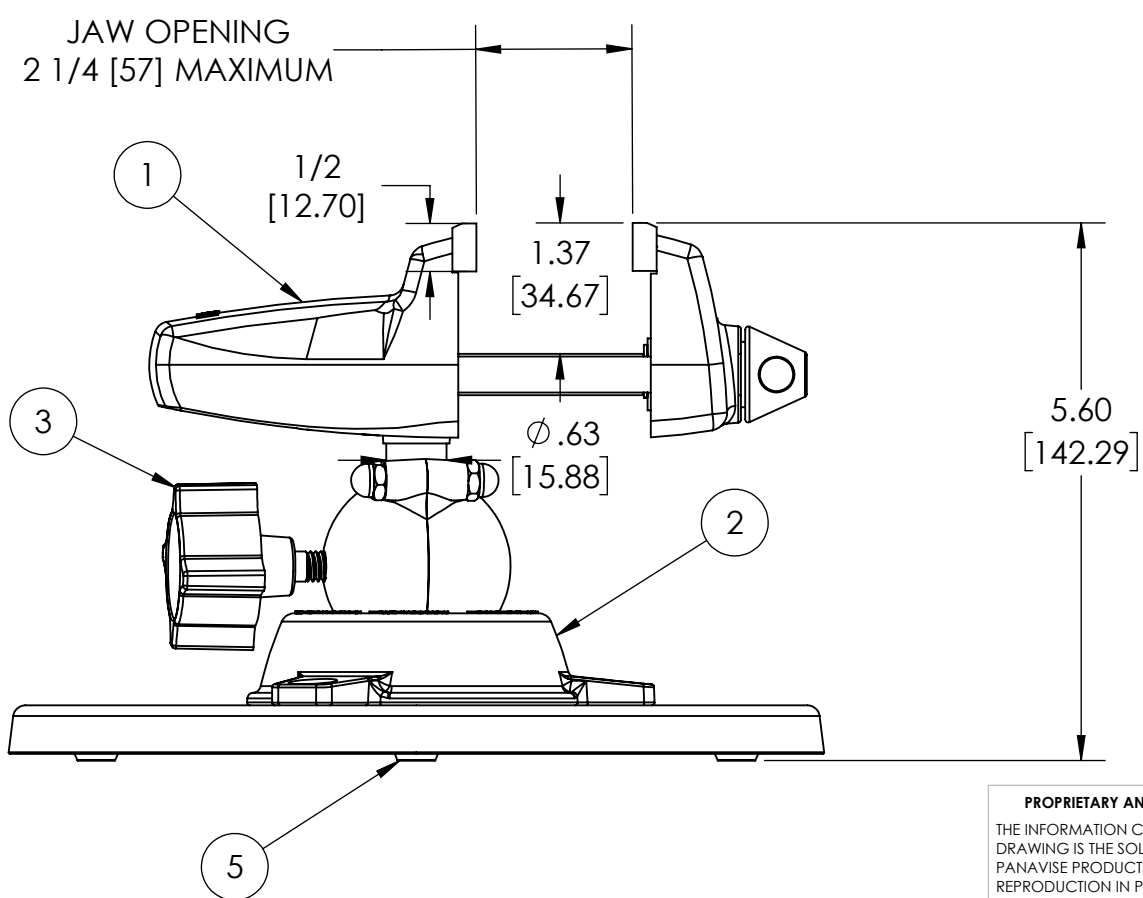

**PROPRIETARY AND CONFIDENTIAL**  
 THE INFORMATION CONTAINED IN THIS DRAWING IS THE SOLE PROPERTY OF PANAVISE PRODUCTS INC. ANY REPRODUCTION IN PART OR AS A WHOLE WITHOUT THE WRITTEN PERMISSION OF PANAVISE PRODUCTS INC IS PROHIBITED.

UNLESS OTHERWISE SPECIFIED:		NAME	DATE	 7540 Colbert Drive, Reno, Nevada 89511-1225 Phone (775) 850-2900 Fax (775) 850-2929 <b>TITLE:</b> LOW PROFILE PANAVISE WORK CENTER SPEC SHEET
DIMENSIONS ARE IN INCHES		DRAWN		
TOLERANCES:		CHECKED		
FRACTIONAL ± 1/64		ENG APPR.		
ANGULAR:		MFG APPR.		
MACH ± 1/2° BEND ±		Q.A.		
TWO PLACE DECIMAL: ±.01		COMMENTS:		
THREE PLACE DECIMAL: ±.005				
INTERPRET GEOMETRIC TOLERANCING PER: ASME 14.5M -2009 MATERIAL				
NEXT ASSY	USED ON	FINISH		
APPLICATION		DO NOT SCALE DRAWING		
SIZE	DWG. NO.	REV		
<b>B</b>	302-SP	<b>A</b>		
SCALE: 1:2	WEIGHT:	SHEET 1 OF 1		