

DO NOT SCALE FROM THIS PRINT

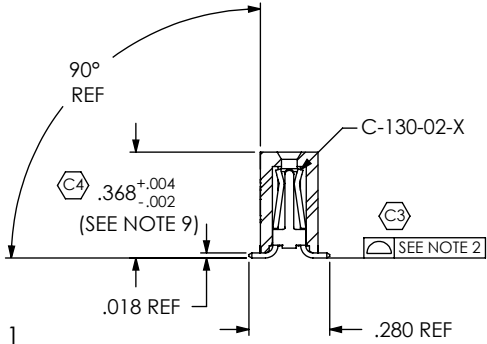
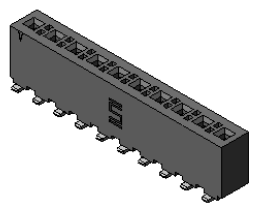
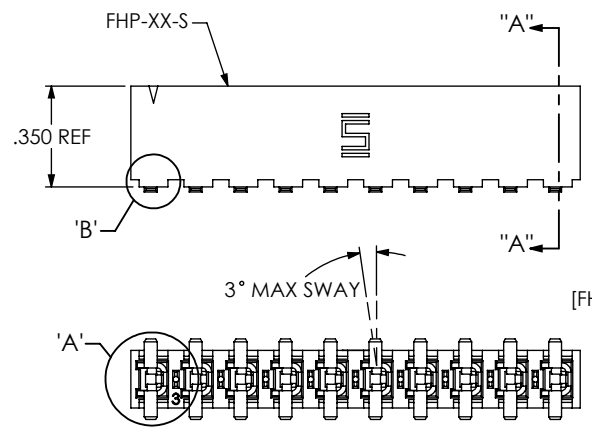
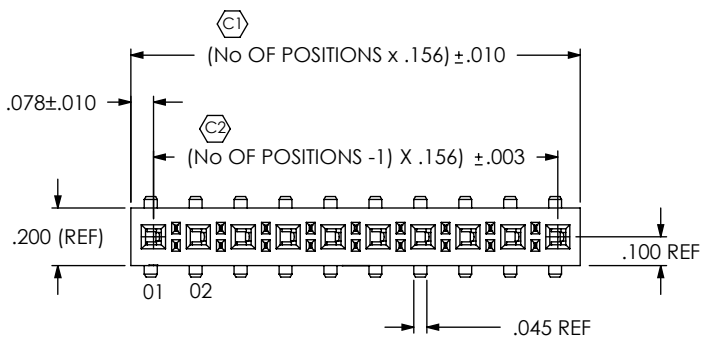

FHP-XX-XX-XX-S-XX-XX

No OF POSITIONS
-02 THRU -24
(PER ROW)
[SEE POSITIONAL FILL VIEW]

LEAD STYLE
-01: THROUGH HOLE
(USE C-130-01-X)
-02: SURFACE MOUNT
(USE C-130-02-X)

OPTION
-TR: TAPE & REEL PACKAGING
(T&R AVAILABLE FOR 2 THRU 18 POS)
(SEE NOTES 6 & 10)

OPTION
-LC: LOCKING CLIP (USE LC-05-TM)
(-02 LEAD STYLE ONLY)
-A: ALIGNMENT PIN (USE FHP-XX-S-A)
(SEE FIG. 2) (-02 LEAD STYLE ONLY)
-K: POLYIMIDE FILM PAD
(SEE FIG. 3, SHT. 2) (USE K-500-300)
(-02 LEAD STYLE ONLY)
(AVAILABLE ON POSITIONS 2-24,
2-4 POSITIONS MUST BE IN -TR)

ROW SPECIFICATION
-S: SINGLE (USE FHP-XX-S)

PLATING SPECIFICATION
-T: TIN (USE C-130-XX-T)
-TM: MATTE TIN (USE C-130-XX-T)
-H: HEAVY GOLD (USE C-130-XX-H)

FIG. 1
[FHP-10-02-X-S SHOWN]

SECTION "A-A"
STYLE -02

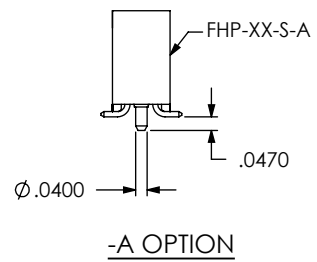
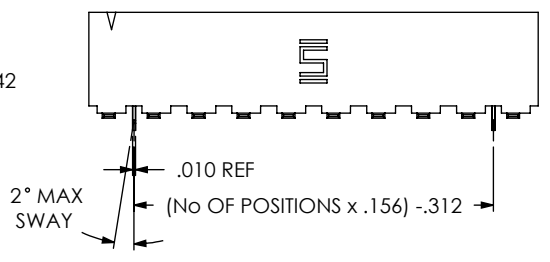
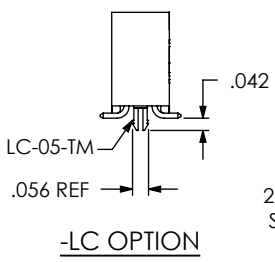
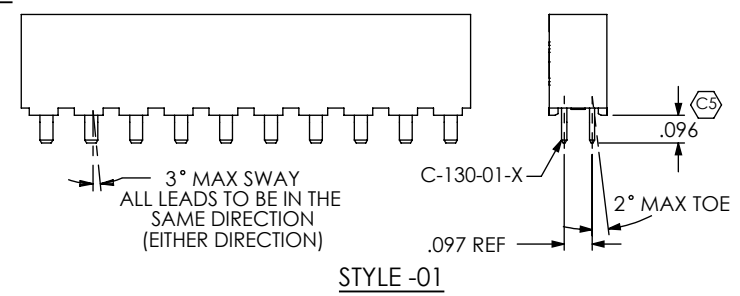
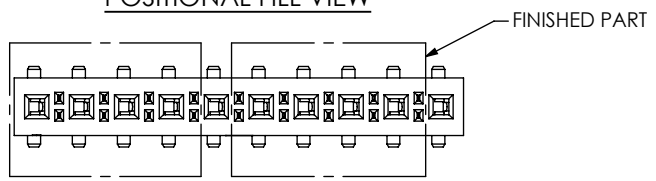

FIG. 2
-LC & -A OPTIONS
[-LC & -A OPTIONS ONLY AVAILABLE ON -02 LEAD STYLE]
(SAME AS FIG. 1, UNLESS OTHERWISE STATED)

NOTES:

1. Ⓢ REPRESENTS A CRITICAL DIMENSION.
2. COPLANARITY TO BE WITHIN .006".
3. BURR ALLOWANCE: .0015 MAX.
4. MAXIMUM CUT FLASH: .020.
5. MINIMUM PUSHOUT FORCE: 1.0 LB.
6. LAYER PACKAGE STYLE -01 & -02, POSITIONS 02 - 04 WITH NO OPTIONS ONLY.
7. OPEN PART OF CONTACT FILLED TOWARDS # 1 PIN INDICATOR
8. MINIMUM WALL THICKNESS TO BE .010".
9. MEASURED @ BEND.
10. TUBE PACKAGING AVAILABLE FOR 5 THRU 24 POSITIONS.

POSITIONAL FILL VIEW



4 POSITION SHOWN
[PRIOR TO CUT-TO-POSITION OPERATION]

UNLESS OTHERWISE SPECIFIED,
DIMENSIONS ARE IN INCHES.
TOLERANCES ARE:
DECIMALS ANGLES
.XX: ±.01
.XXX: ±.005
.XXXX: ±.0020

PROPRIETARY NOTE
THIS DOCUMENT CONTAINS INFORMATION
CONFIDENTIAL AND PROPRIETARY TO
SAMTEC, INC. AND SHALL NOT BE REPRODUCED
OR TRANSFERRED TO OTHER DOCUMENTS OR
DISCLOSED TO OTHERS OR USED FOR ANY
PURPOSE OTHER THAN THAT WHICH IT WAS
OBTAINED WITHOUT THE EXPRESSED WRITTEN
CONSENT OF SAMTEC, INC.

520 PARK EAST BLVD, NEW ALBANY, IN 47150
PHONE: 812-944-6733 FAX: 812-948-5047
e-Mail: info@SAMTEC.com code: 55322

MATERIAL: DO NOT SCALE DRAWING SHEET SCALE: 1.5:1
MATERIAL: VECTRA E130i
COLOR: BLACK
CONTACT: BeCu, 174HT

DESCRIPTION: .156 HI POWER SOCKET ASSEMBLY

DWG. NO. FHP-XX-XX-XX-S-XX-XX

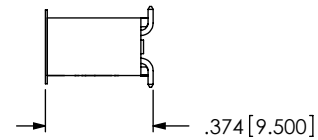
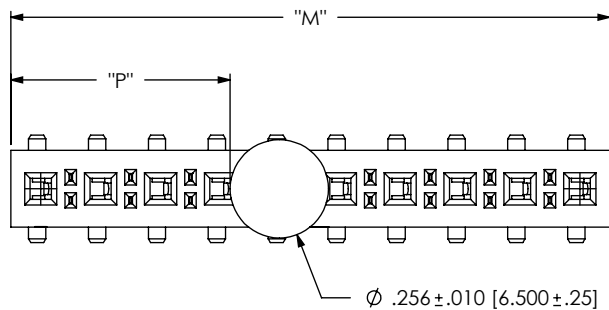

NOTE: "M" = USED MEASURED DIMENSION (REF)
 "P" = $\{("M" - .256 [6.50]) / 2\} \pm .020 [.51]$

FIG. 3
 -K: POLYIMIDE FILM PAD OPTION
 (SHOWN: FHP-10-02-X-S-K)

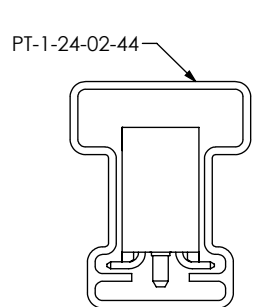

STYLE -02
 (WITH ALIGNMENT PIN)

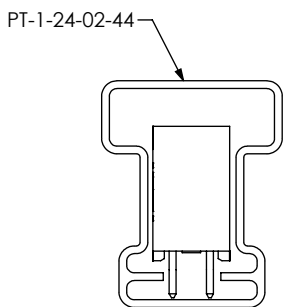

STYLE -01

(TUBE PACKAGING AVAILABLE FOR 5 THRU 24 POS)
 (TUBE PACKAGE THE PARTS WITH #1 PIN TOWARDS ARROW)

PACKAGING TABLE

LEAD STYLE	OPTIONS	PACKAGING TUBE	PLUG
-01	ALL OPTIONS	PT-1-24-02-44	TP-03
-02	ALL OPTIONS	PT-1-24-02-44	TP-03

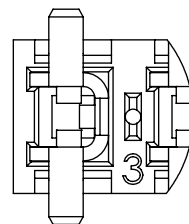

DETAIL 'A'
 SCALE 4:1
 (SHOWN FOR CONTACT ORIENTATION)

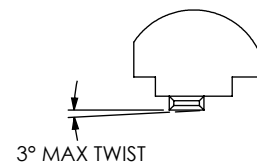

DETAIL 'B'
 SCALE 4:1

c:\enterprise\vauff\DWG\MISC\MKTG\FHP-XX-XX-XX-S-XX-XX-MKT.SLDDRW

PROPRIETARY NOTE
 THIS DOCUMENT CONTAINS INFORMATION CONFIDENTIAL AND PROPRIETARY TO SAMTEC, INC. AND SHALL NOT BE REPRODUCED OR TRANSFERRED TO OTHER DOCUMENTS OR DISCLOSED TO OTHERS OR USED FOR ANY PURPOSE OTHER THAN THAT WHICH IT WAS OBTAINED WITHOUT THE EXPRESSED WRITTEN CONSENT OF SAMTEC, INC.

DO NOT SCALE DRAWING

SHEET SCALE: 1.5:1

520 PARK EAST BLVD, NEW ALBANY, IN 47150
 PHONE: 812-944-6733 FAX: 812-948-5047
 e-Mail: info@SAMTEC.com code: 55322

DESCRIPTION: .156 HI POWER SOCKET ASSEMBLY

DWG. NO. FHP-XX-XX-XX-S-XX-XX

BY: BRATCHER 03/01/99 SHEET 2 OF 2