

**NOTES:** UNLESS OTHERWISE SPECIFIED

1. ALL DIMENSIONS ARE FOR REFERENCE ONLY.

MATERIAL & FINISHES

- ① RECEPTACLE SHELL — MATERIAL-ALUMINUM  
FINISH-BLACK HARD ANODIZE
- ② INSERT — MATERIAL-TPV
- ③ PANEL GASKET — MATERIAL-NEOPRENE, BLACK
- ④ SOCKET CONTACT — SIZE-10, SOLDER  
PART NO.-49151T58  
QUANTITY-19  
WIRE SIZE-12 AWG.  
MATERIAL-COPPER ALLOY  
FINISH-GOLD PLATED

**ITT ISSUED**  
By rosa.silva at 10:51 am, Sep 08, 2008

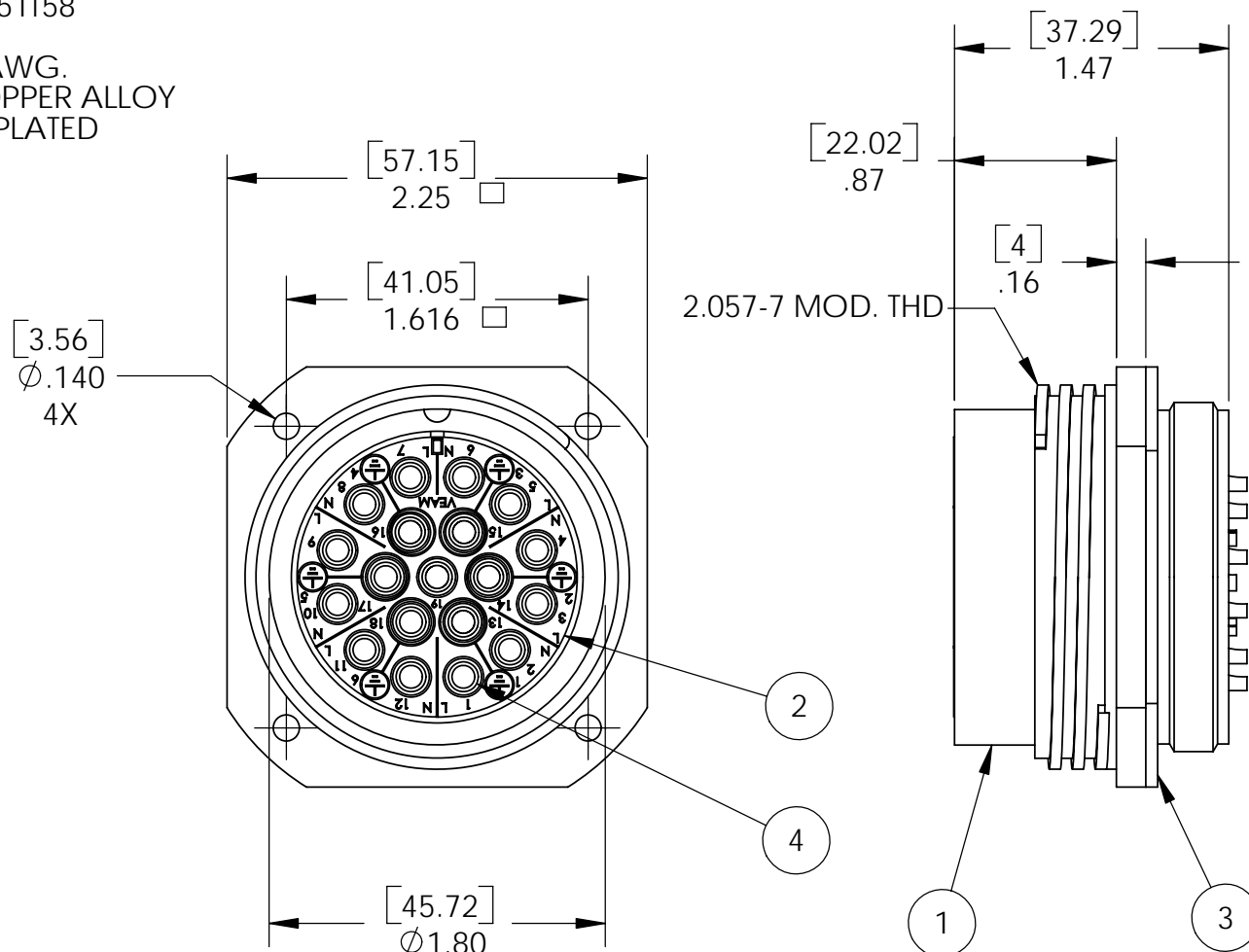

THIS DOCUMENT AND THE INFORMATION CONTAINED HEREIN IS THE SOLE PROPERTY OF ITT VEAM LLC AND IS NOT TO BE COPIED, REPRODUCED, DISCLOSED OR TRANSFERRED BY ELECTRONIC MEDIA WITHOUT THE EXPRESSED PERMISSION OF ITT VEAM LLC. VIOLATIONS SUBJECT TO PENALTIES PROVIDED UNDER U.S. AND INTERNATIONAL LAW.

DOCUMENT GENERATED BY SOLIDWORKS			
REV.	DESCRIPTION	DATE	APPROVED
A	RELEASED PER ER #887	NR 3/10/04	AR
B	REVISED ITEM# 2. REVISED CATALOG No. ECR# 06-183	JG 8/31/06	-

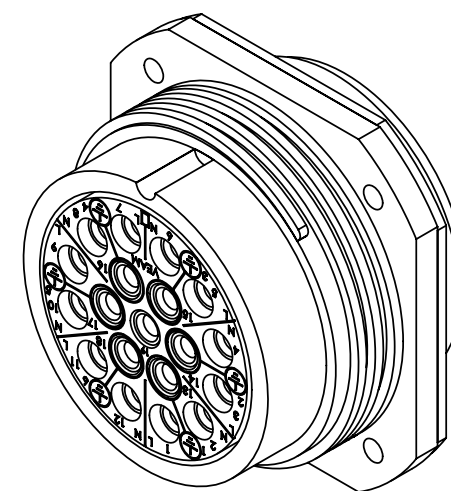

**CATALOG NO. VSC02SS**

<b>CUSTOMER DRAWING</b>		<b>VEAM</b> 100 NEW WOOD ROAD, WATERTOWN, CT. 06795		  <i>Engineered for life</i>	
UNLESS OTHERWISE SPECIFIED: DIMENSIONS ARE IN (MM) INCHES		TITLE: VSC SIZE 32,FEMALE,PANEL MOUNT SOLDER			
SCALE: 1:1			SIZE <b>B</b>	DWG. NO. Z80737	REV B
DRAWN NR	DATE 03/09/04		PROJECT# 4423		
CHECKED A.R	DATE 03/11/04		CAGE CODE: 55561		
APPROVED A.R	DATE 03/11/04	SHEET 1 OF 1			