

THIS DRAWING IS UNPUBLISHED
 VERTRÄULICHE UNVERÖFFENTLICHTE ZEICHNUNG
 RELEASED FOR PUBLICATION
 FREI FUER VERÖFFENTLICHUNG
 2007
 MATED WITH:
 PASSEND ZU:
 © COPYRIGHT 2007 BY TYCO ELECTRONICS CORPORATION. ALL RIGHTS RESERVED.
 ALLE RECHTE VORBEHALTEN

LOC	DIST	P	LTR	REVISIONS ÄNDERUNGEN DESCRIPTION BESCHREIBUNG	DATE	DWN	APVD
A1	-						
PROJEKT NR.: EGGMN06057				A2	ECR-08-005111	28.02.2008	N.T. R.K.
				A3	ECR-08-009551	15APR2008	N.T. R.K.
				A4	ECR-08-010059	22APR2008	N.T. R.K.
				A5	ECR-08-010777	28APR2008	N.T. R.K.

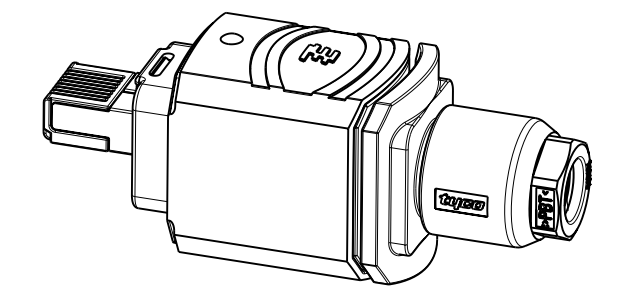

SCALE 1:1 / M 1:1

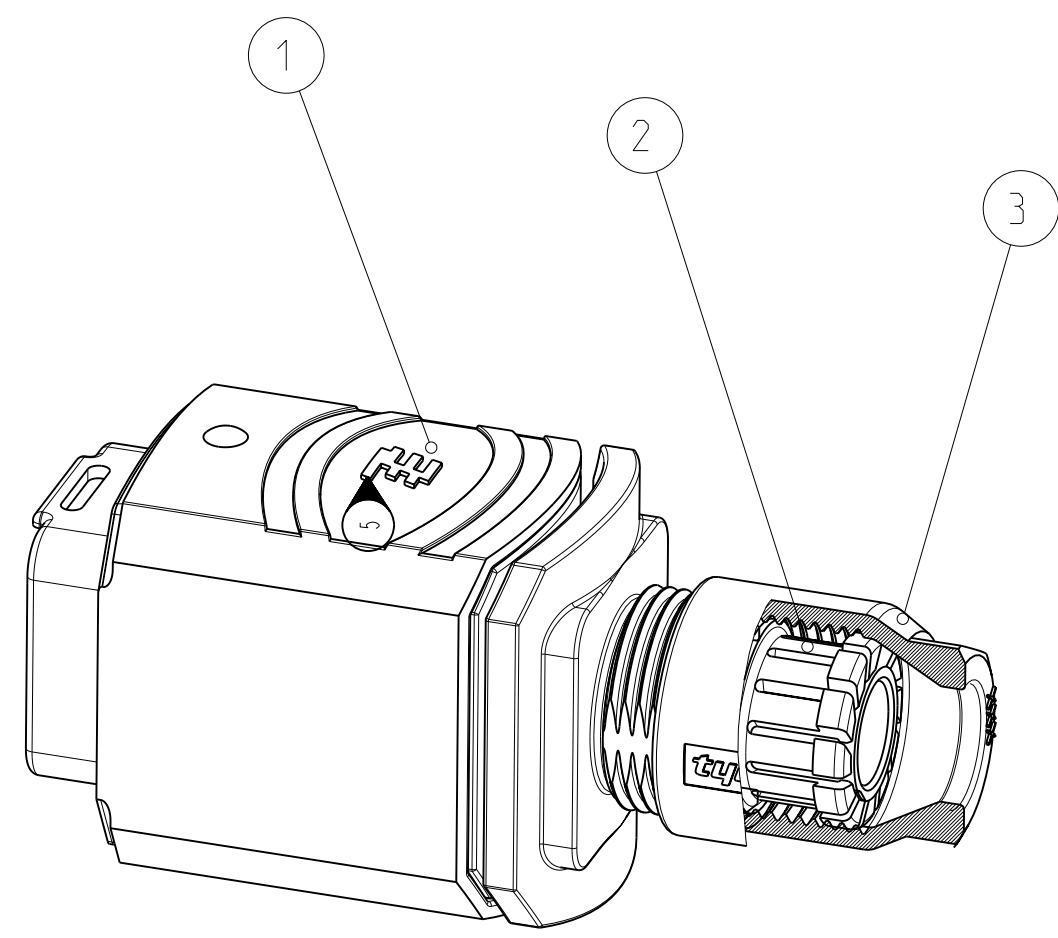
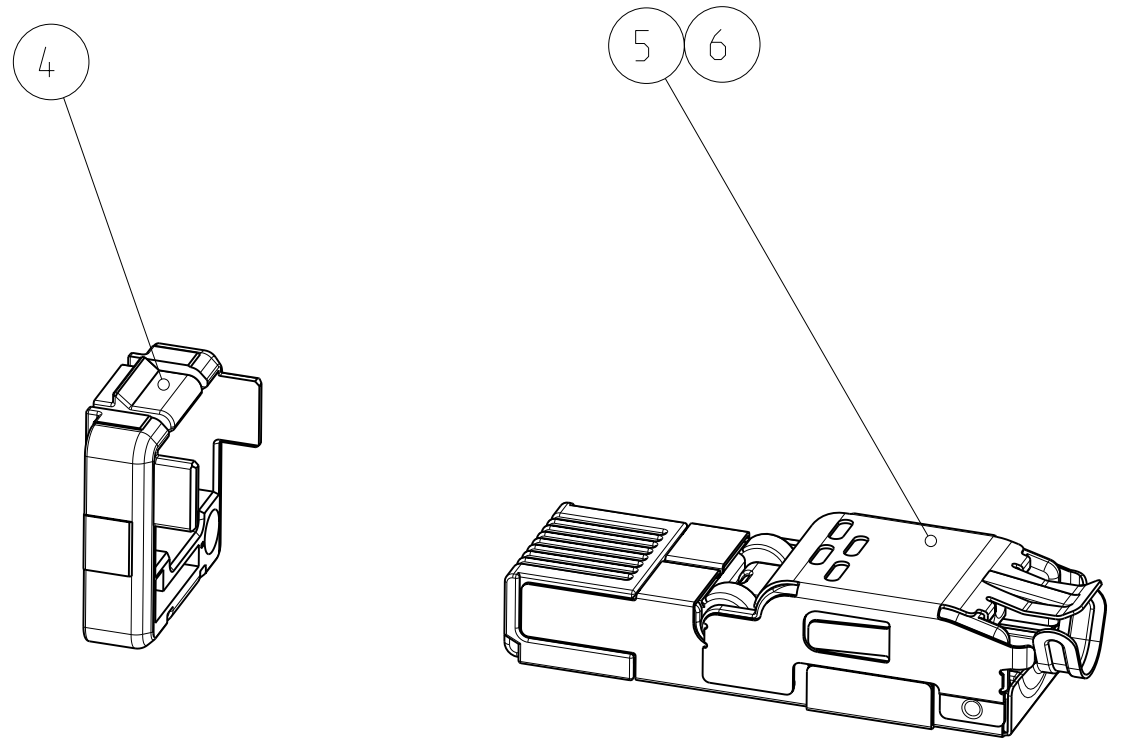
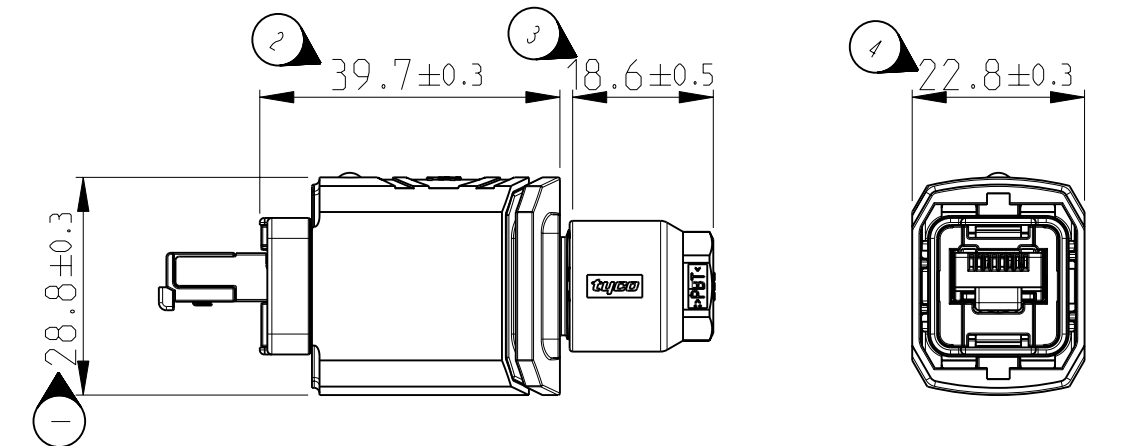

SCALE 1:1 / M1:1

1 NOT SHOWN

2 COMPONENTS BULK PACKAGED IN PLASTIC BAG.

3 PRINTING FOR THE LABEL: QUANTITY, TE PN, REVISION, PRODUCTION DATE

4 MANUAL: A4 PRINTED.

-1 AS SHOWN
 -1 WIE GEZEICHNET

1 NICHT DARGESTELLT

2 KOMPONENTEN LOSE VERPACKT IN PLASTIK BEUTEL.

3 BESCHRIFTUNG FUER DAS ETIKETT: STUECKZAHL, TE PN, REVISION STAND, PRODUKTIONSdatum

4 ANLEITUNG: DIN A4 BEDRUCK, DRUCKVORLAGE MUSS NOCH FESTGELEGT WERDEN.

QTY REQD PER ASSY	REVISION OF EACH ASSY NO. (WHEN BLANK, USE DWG. REVISION)	DESCRIPTION	ITEM NO
1	1	PLASTIC BAG	8
-	-	MANUAL	7
-	-	CORE 8P ASSY	6
-	-	CORE 4P ASSY	5
-	-	RETENTION CLIP, RJ45, PUSH-PULL	4
-	-	CABLE SCREW JOINT	3
-	-	PINCH RING SEAL, ASSY	2
-	-	RJ45 PLUG, PUSH-PULL, SUB-ASSY	1

THIS DRAWING IS A CONTROLLED DOCUMENT FOR TYCO ELECTRONICS CORPORATION IT IS SUBJECT TO CHANGE AND THE CONTROLLING ENGINEERING ORGANIZATION SHOULD BE CONTACTED FOR THE LATEST REVISION. DIESES ZEICHNUNGSDOKUMENT WIRD DURCH AMP INCORPORATED KONTROLLIERT. ÄNDERUNGEN, DIE DEM TECHNISCHEN FORTSCHRITT DIENEN, SIND VORBEHALTEN. DEN JEWELIS LETZTGÜLTIGEN ÄNDERUNGSSTAND ERFAHREN SIE AUF ANFRAGE.		DWN N. THIRUNAVUKKARASU 23MAR2007 CHK W. BOECK 23MAR2007 APVD R. KRAEMER 23MAR2007	tyco Electronics tyco Electronics AMP GmbH 64625 Bensheim (Germany)
DIMENSIONS: MASSE IN HEIßEN: (MM)		TOLERANCES UNLESS OTHERWISE SPECIFIED: ALLGEMEINTOLERANZEN 0 PLC ±- 1 PLC ±- 2 PLC ±- 3 PLC ±- 4 PLC ±- ANGLES/WINKEL ±- FINISH/OBERFLÄCHE/FARBE	NAME RJ45 PLUG, PUSH-PULL, ASSY RJ45 STECKER, PUSH-PULL, ASSY CAT5, SHIELDED
MATERIAL - PBT/ PC / TPE		APPLICATION SPEC VERARBEITUNGSSPEZ. - WEIGHT GEWICHT -	SIZE A2 CAGE CODE 00779 DRAWING NO. ZEICHNUNGS-NR. 1987004 RESTRICTED TO NUR FUER -
CUSTOMER DRAWING		/KUNDENZEICHNUNG	SCALE MASSSTAB 2:1 SHEET BLATT 1 OF 1 REV A5