

1		2		3			4			5			6				7		8				
Material-No.	Order-No.	Shell Size / for No. of Contacts	A ±0.3	B ±0.1	C ±0.3	D ±0.3	E ±0.3	∅F min - max	G ±0.3	H ±0.3	J ±0.3	K ±0.3	L ±0.3	M ±0.3	N ±0.3	P ±0.3	R ±0.3	∅F = Cable diameter					
1731110433	FKI1A	1 / 9	11.5	25	36	36	16	3.5 - 7.5	22	-	12.4	17.2	-	20.4	15.7	12.8	11.9						
1731110207	FKI1AE																						
1731110440	FKI2A	2 / 15		33.3	44.3	42			6.5 - 9	27.3		13.7		22	24.6	28	19.9			16.1			
1731110441	FKI2AE																						
1731110448	FKI3A	3 / 25		47	58					6.5 - 11		41	15		35.6	38.8	42	19.5	17		15.7		
1731110449	FKI3AE																						
1731110452	FKI4A	4 / 37		63.5	74.5					6.5 - 11		57.5	15.4		52.3	55.3	58.5	19.4			15.6		
1731110453	FKI4AE																						
-	FKI5A	5 / 50		14.2	61.1			73		19		9 - 13	55	16.5	19.3	49.8	53.4	65.8	17.4	19	13.9		
-	FKI5AE																						

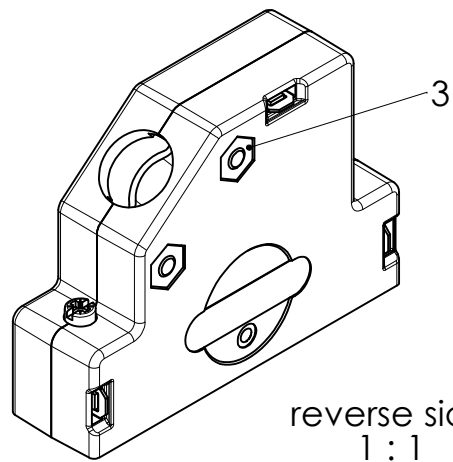
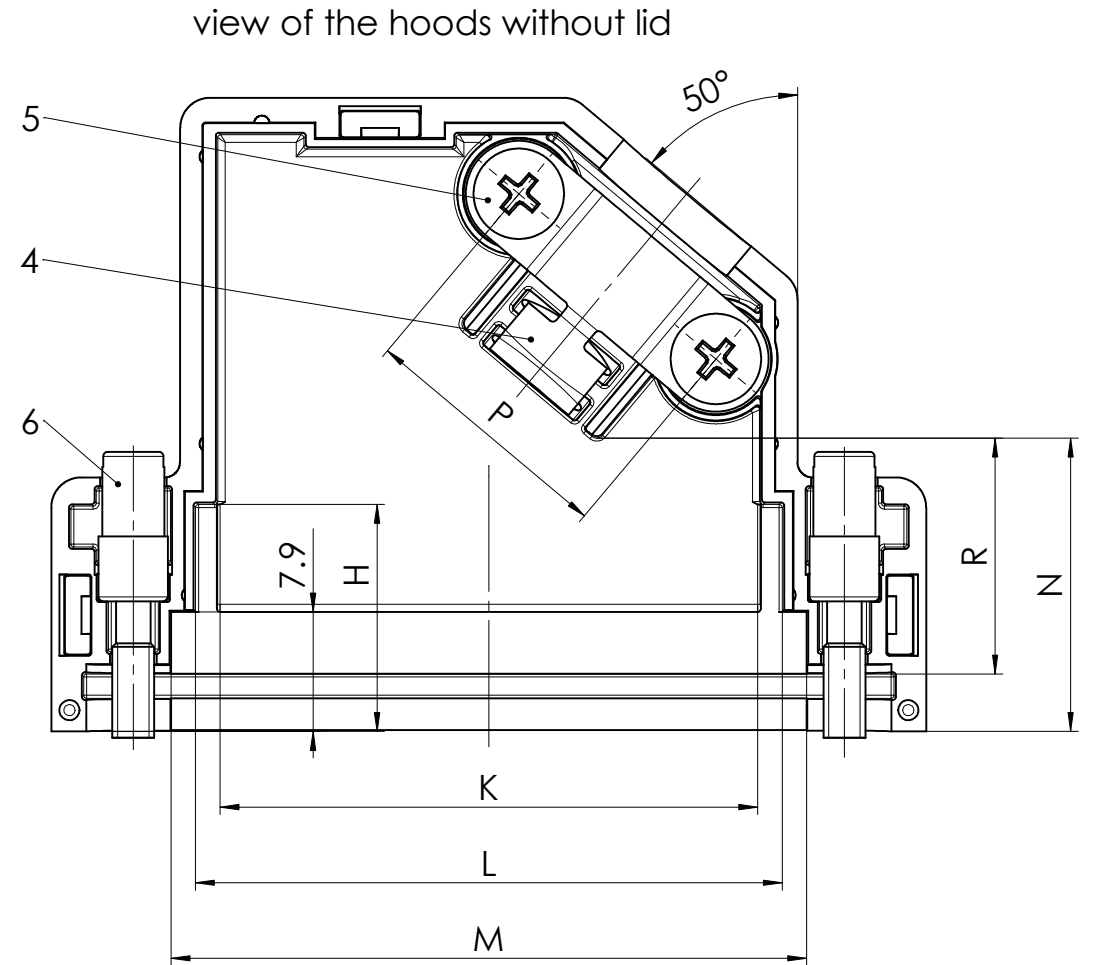
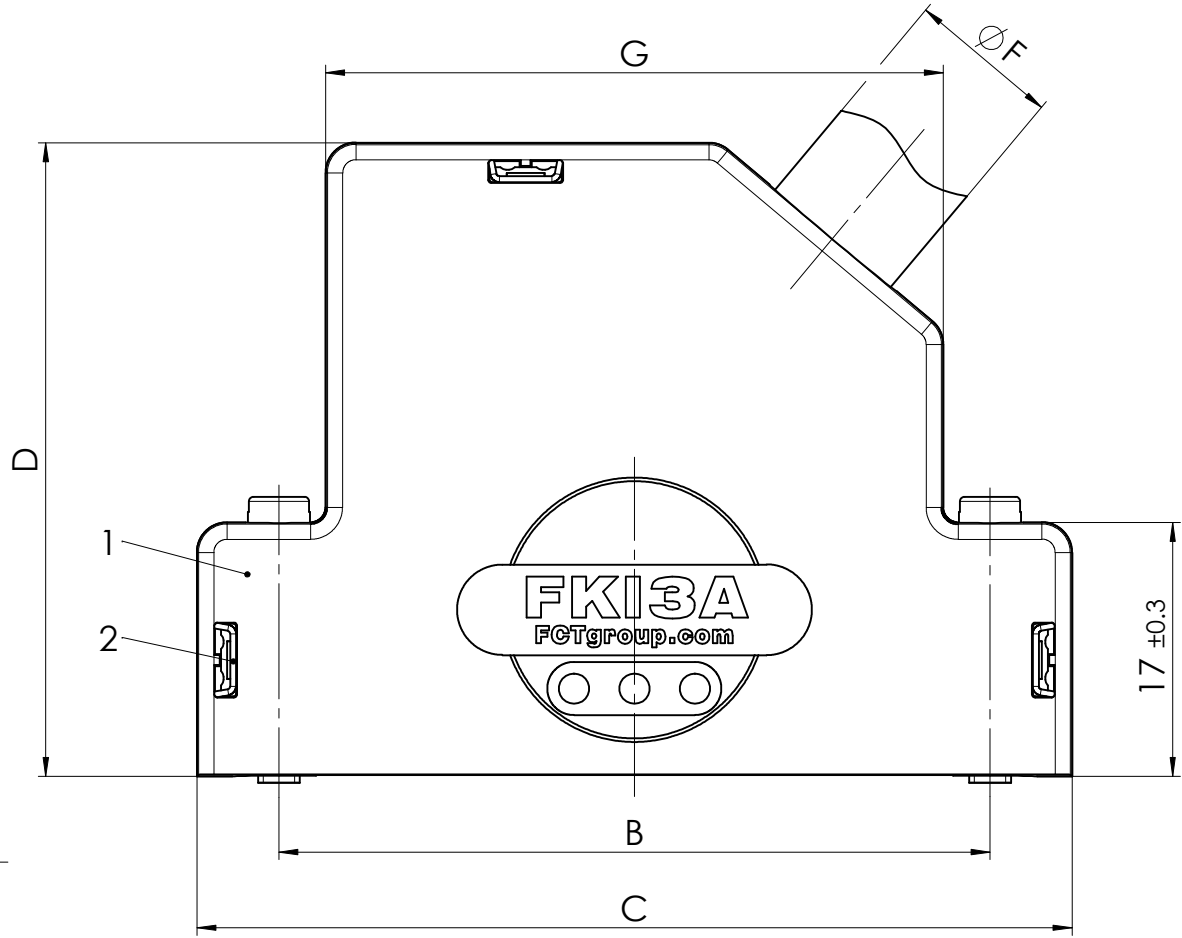
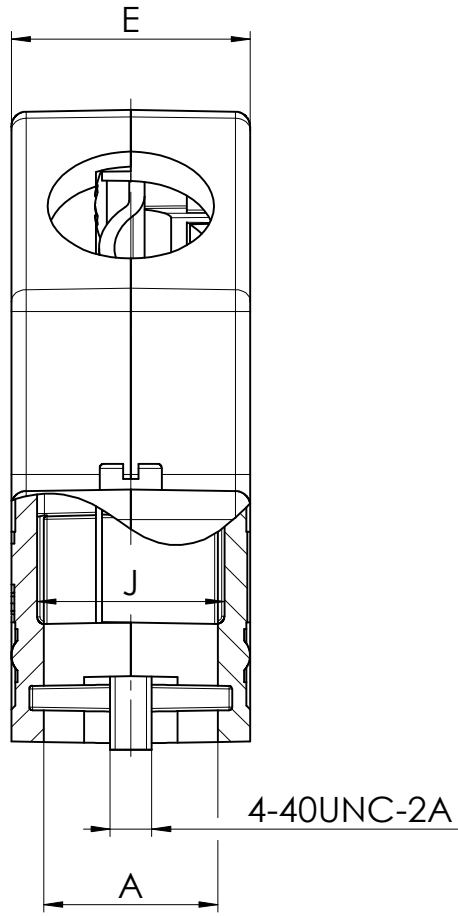

reverse side  
1:1

RoHS compliant  
by exemption

max. torque are 40 Ncm  
Hood is snapped together  
Part-No. 4, 5 and 6 not mounted

FKI1-5A - Units per carton  
FKI1-5AE - Individually packed

No.	St.	Part	Type Description/Material	Surface plating/Colour/Class
6	2	Locking screw	FVS1/5-4368 4-40 / Steel	nickel plated
5	2	Cable clamp screw	Steel	zinc plated
4	1	Cable clamp	Steel	tin plated
3	2	Locking nut	Brass	tin plated
2	3	Locking element sheet	Spring steel	blank
1	1	Hood	FKI1-5A / ABS	nickel plated

SYMBOLS					THIS DRAWING CONTAINS INFORMATION THAT IS PROPRIETARY TO MOLEX ELECTRONIC TECHNOLOGIES, LLC AND SHOULD NOT BE USED WITHOUT WRITTEN PERMISSION				
∇ = 0	∇ = 0	∇ = 0	∇ = 0	∇ = 0	DIMENSION UNITS	SCALE	MEASUREMENTS WITHOUT TOLERANCE ACC. TO	<b>molex</b>	
∇ = 0	∇ = 0	∇ = 0	∇ = 0	∇ = 0	mm	2:1	ISO 2768-m		
∇ = 0	∇ = 0	∇ = 0	∇ = 0	∇ = 0	CURRENT REVISION			PRODUCT CUSTOMER DRAWING	
∇ = 0	∇ = 0	∇ = 0	∇ = 0	∇ = 0	DRWN: DRAWN BY BWittek 26-04-2019			FCT-Plastic Hood	
∇ = 0	∇ = 0	∇ = 0	∇ = 0	∇ = 0	APPR: APPR BY ameyerrichte 29-04-2019			MATERIAL NUMBER	
∇ = 0	∇ = 0	∇ = 0	∇ = 0	∇ = 0	INITIAL REVISION			REVISION	
∇ = 0	∇ = 0	∇ = 0	∇ = 0	∇ = 0	7	24131	DRWN: DRAWN BY Anke.Meyer-Richter 18-06-2010	see table	
∇ = 0	∇ = 0	∇ = 0	∇ = 0	∇ = 0	REV.	CH.-NO.	APPR: APPR BY katja.schoeber 25-08-2010	7	
∇ = 0	∇ = 0	∇ = 0	∇ = 0	∇ = 0	REPLACEMENT FOR:			DOCUMENT NUMBER	
∇ = 0	∇ = 0	∇ = 0	∇ = 0	∇ = 0	THIRD ANGLE PROJECTION			FKI1-5A	
∇ = 0	∇ = 0	∇ = 0	∇ = 0	∇ = 0	DRAWING			CUSTOMER	
∇ = 0	∇ = 0	∇ = 0	∇ = 0	∇ = 0	A3-SIZE			GENERAL MARKET	
∇ = 0	∇ = 0	∇ = 0	∇ = 0	∇ = 0				SHEET NUMBER	
∇ = 0	∇ = 0	∇ = 0	∇ = 0	∇ = 0				1 OF 1	

COMMENT: ALL RIGHTS ARE RESERVED BY US FOR THIS DRAWING. WITHOUT OUR PRIOR CONSENT, IT MAY NEITHER BE DUBLICATED NOR MADE AVAILABLE TO A THIRD PARTY. AND IT ALSO MAY NOT BE IMPROPERLY USED BY THE RECEIVER, OR A THIRD PARTY.