

DO NOT
SCALE FROM
THIS PRINT

SOME CENTER FEATURES
NOT SHOWN FOR CLARITY

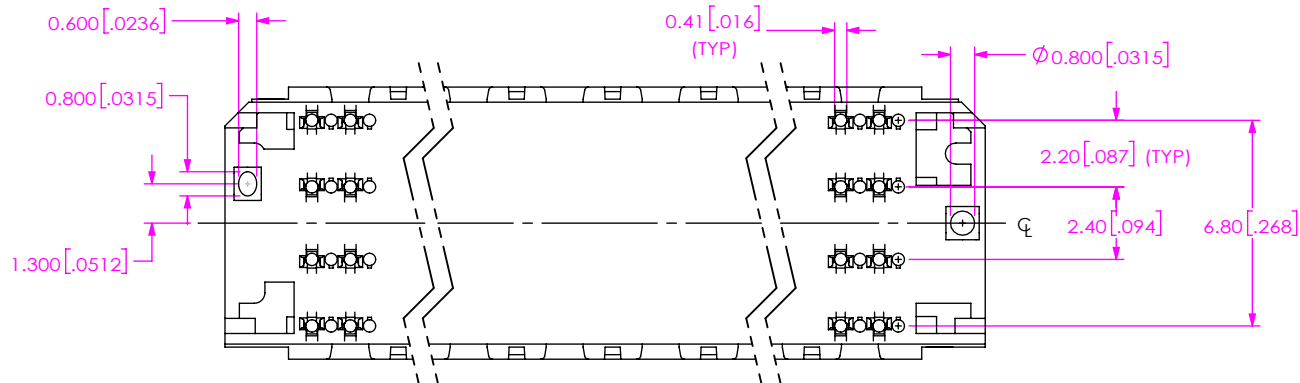
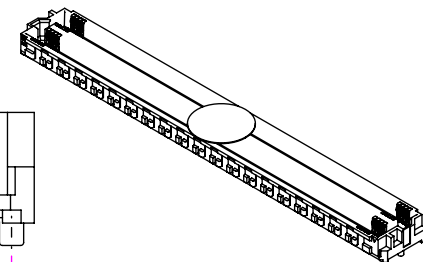
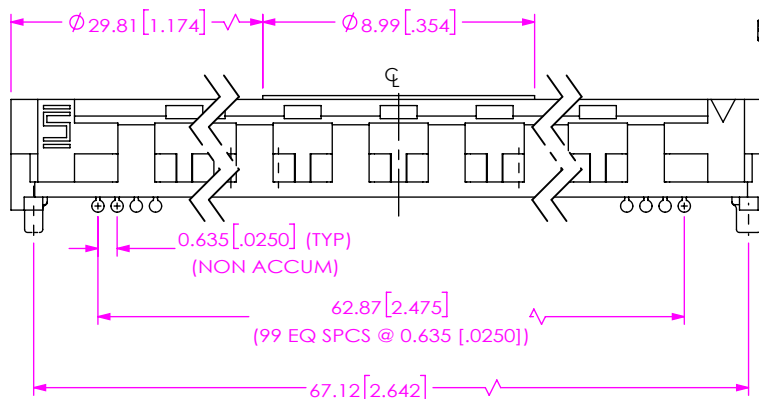
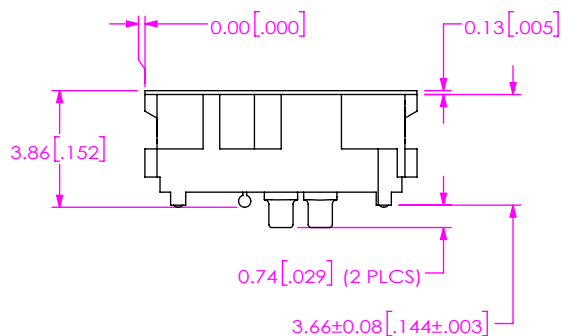
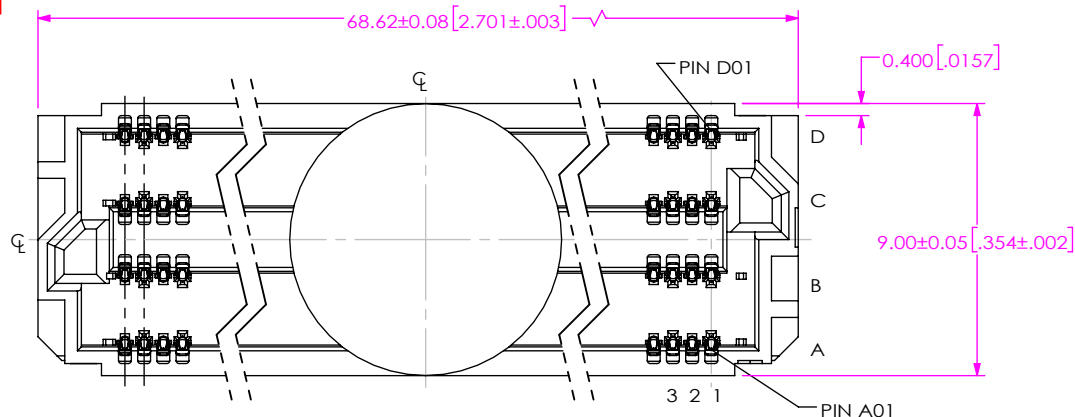

- NOTES:
- NOTE DELETED.
 - PARTS TO BE PACKAGED IN TAPE & REEL.
 - SEE SHT 2 FOR PROCESSING INFORMATION.
 - ORDERS WILL BE PACKAGED ACCORDING TO THE SAMTEC PACKAGING EFFICIENCY STANDARDS (SPES) FOUND ON WWW.SAMTEC.COM
 - ATTACH LABEL-4X2 TO EACH TAPE & REEL PACKAGE.
 - K-DOT PROVIDED AS STANDARD.
 - MEASURE BOTH OUTSIDE ROWS ONLY.

PROPRIETARY NOTE
THIS DOCUMENT CONTAINS CONFIDENTIAL AND PROPRIETARY INFORMATION AND ALL DESIGN, MANUFACTURING, REPRODUCTION, USE, PATENT RIGHTS AND SALES RIGHTS ARE EXPRESSLY RESERVED BY SAMTEC, INC. THIS DOCUMENT SHALL NOT BE DISCLOSED, IN WHOLE OR PART, TO ANY UNAUTHORIZED PERSON OR ENTITY NOR REPRODUCED, TRANSFERRED OR INCORPORATED IN ANY OTHER PROJECT IN ANY MANNER WITHOUT THE EXPRESS WRITTEN CONSENT OF SAMTEC, INC.

DO NOT SCALE DRAWING SHEET SCALE: 4:1

MATERIAL:
INSULATOR: LCP, COLOR: NATURAL
CONTACT: COPPER ALLOY
PLATING:
CONTACT AREA: .00010" GOLD OVER .000050" NICKEL
REMAINDER: .000200" REF TIN OVER .000050" NICKEL
F:\DWG\MISC\MKTG\ASP-209946-01-MKT.SLDDRW

samtec

520 PARK EAST BLVD, NEW ALBANY, IN 47150
PHONE: 812-944-6733 FAX: 812-948-5047
e-Mail: info@SAMTEC.com code 55322

DESCRIPTION:
CUSTOM COM HPC FEMALE ASSEMBLY

DWG. NO.
ASP-209946-01

BY: J. BROWNING 01/16/2019 SHEET 1 OF 2

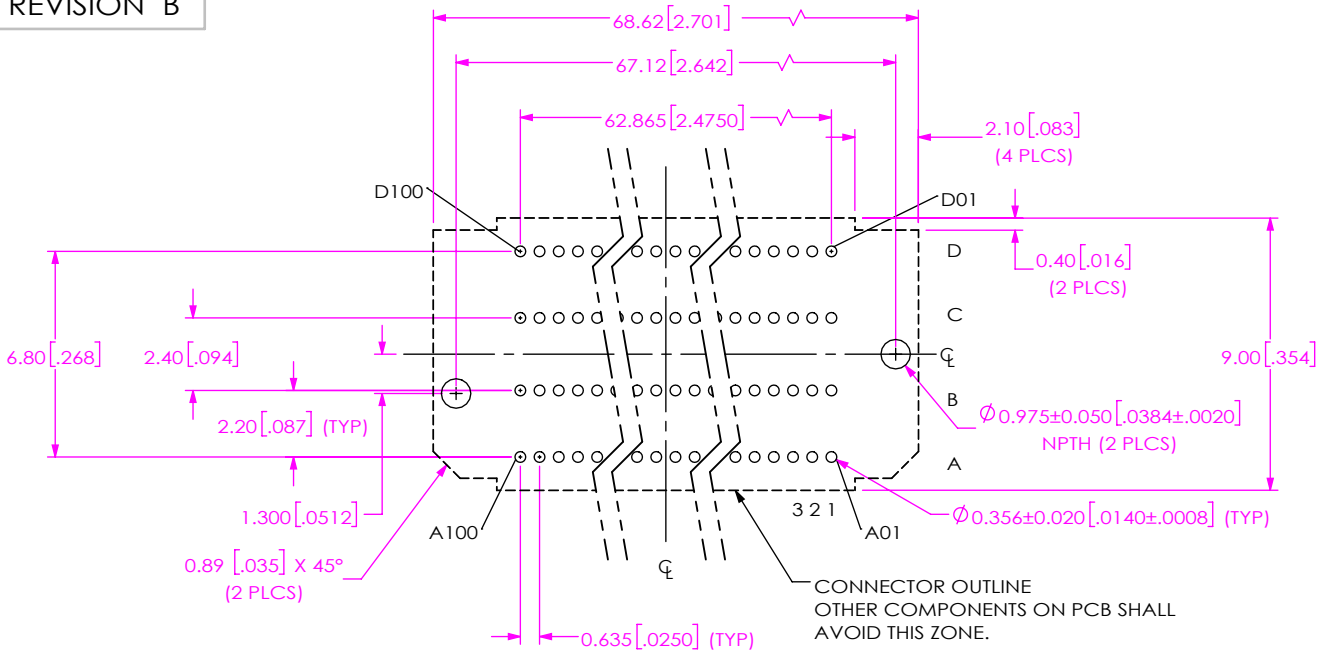

RECOMMENDED PCB LAYOUT
ALL DIMENSIONS SYMMETRIC ABOUT CENTERLINE

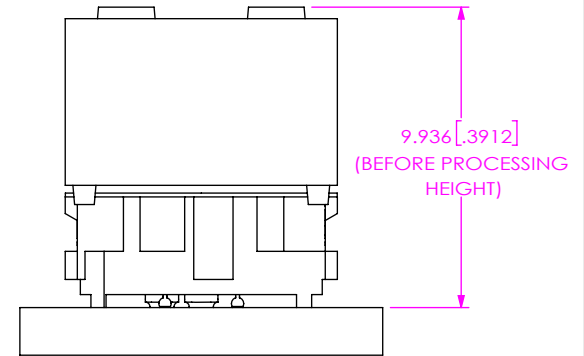

PROCESSING VIEW
DIMENSION INDICATES CONNECTOR/FIXTURE HEIGHT ON PCB TO GUARANTEE ENOUGH REFLOW OVEN WORKING SPACE. DIMENSION, PCB THICKNESS, AND THE HEIGHT OF THE COMPONENTS ON THE OTHER SIDE OF THE BOARD NEED TO BE CONSIDERED.

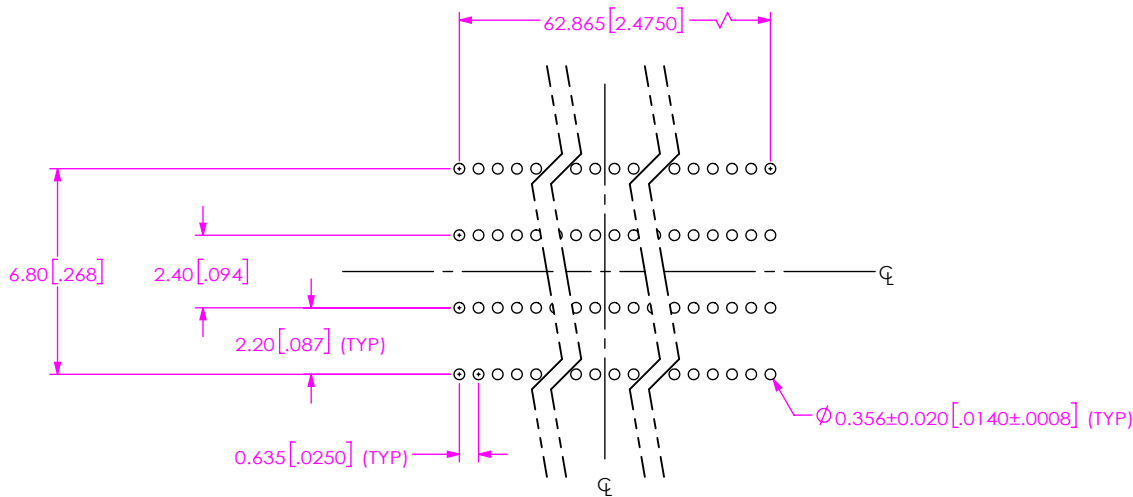

RECOMMENDED STENCIL LAYOUT
ALL DIMENSIONS SYMMETRIC ABOUT CENTERLINE
(STENCIL TO BE 0.125 [.0050] THICK)

PROPRIETARY NOTE
THIS DOCUMENT CONTAINS CONFIDENTIAL AND PROPRIETARY INFORMATION AND ALL DESIGN, MANUFACTURING, REPRODUCTION, USE, PATENT RIGHTS AND SALES RIGHTS ARE EXPRESSLY RESERVED BY SAMTEC, INC. THIS DOCUMENT SHALL NOT BE DISCLOSED, IN WHOLE OR PART, TO ANY UNAUTHORIZED PERSON OR ENTITY NOR REPRODUCED, TRANSFERRED OR INCORPORATED IN ANY OTHER PROJECT IN ANY MANNER WITHOUT THE EXPRESS WRITTEN CONSENT OF SAMTEC, INC.



520 PARK EAST BLVD, NEW ALBANY, IN 47150
PHONE: 812-944-6733 FAX: 812-948-5047
e-Mail info@SAMTEC.com code 55322

SHEET SCALE: 2:1

DESCRIPTION:
CUSTOM COM HPC FEMALE ASSEMBLY

DWG. NO.
ASP-209946-01