

TOLERANCE UNLESS OTHERWISE SPECIFIED	
.X	±0.15
.XX	±0.10

THIS IS A C.A.D. GENERATED DRAWING
DO NOT MAKE MANUAL REVISIONS TO MASTER.

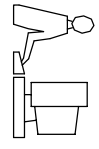

ISSUE NUMBER
ORIGINAL
①

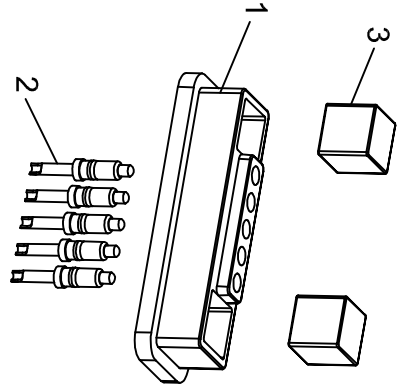
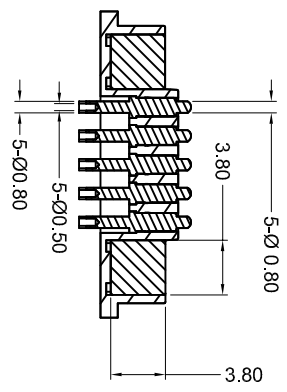
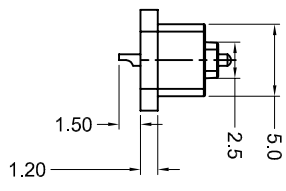
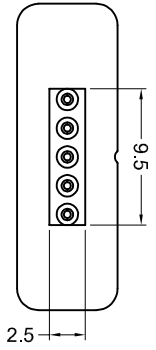
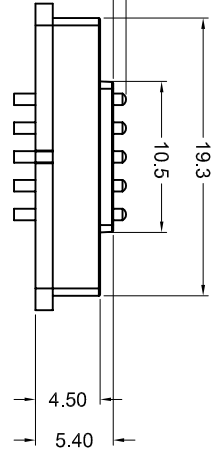
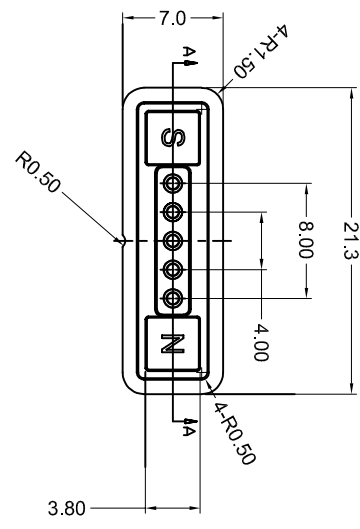

SECTION A-A

3D VIEW

SPECIFICATION:

VOLTAGE RATING: 5V

CURRENT RATING: 2A

INSULATION RESISTANCE: 100MEGA OHM MIN

DIELECTRIC WITHSTAND VOLTAGE: 100V AT 60HZ

CONTACT RESISTANCE: 30mOHM MAX. BEFORE TEST AND 60mOHM MAX. AFTER TEST

WORKING STROKE ON SINGLE PIN: PRESS STROKE 0.9mm (PER CONTACT) 30gf MAX.

LIFE CYCLE TEST: PRESS STROKE 0.9mm, 10,000 TIMES MIN

SALT SPRAY TEST: 5% SALT SPRAY CONCENTRATION, TEMPERATURE 35°C, TEST TIME 48 HOURS, NO CORROSION

OPERATING TEMPERATURE RANGE: -30°C~+85°C

POGO CONNECTOR, 5 POS, MALE

ACAD REFERENCE NO.: M00-PG0-105-103	
DRAWN: E.S.	DATE: JUN 6/2022
CHECKED: R.S.M.	DATE: JUN 6/2022
SCALE: (IN C.A.D. 1:1)	SHEET 1 OF 1
DRAWING NUMBER: M00-PG0-105-103	ISSUE
PART NUMBER: M00-PG0-105-103	1

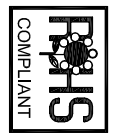

THIS SERIES FULLY CONFORMS TO
THE EUROPEAN UNION DIRECTIVES
2011/65/EU FOR ROHS COMPLIANCY.



EDAC INC
TORONTO, ONTARIO
CANADA

THESE DRAWINGS AND SPECIFICATIONS
ARE THE PROPERTY OF EDAC INC. AND
SHALL NOT BE REPRODUCED OR COPIED
OR USED AS THE BASIS FOR THE
MANUFACTURE OR SALE OF APPARATUS
WITHOUT WRITTEN PERMISSION.

YOUR CONNECTION TO QUALITY & SERVICE