

TOLERANCE UNLESS OTHERWISE SPECIFIED		
.X	±0.15	
.XX	±0.10	

THIS IS A C.A.D. GENERATED DRAWING  
DO NOT MAKE MANUAL REVISIONS TO MASTER.

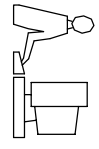

ISSUE NUMBER	1
ORIGINAL	

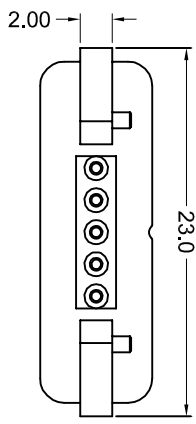
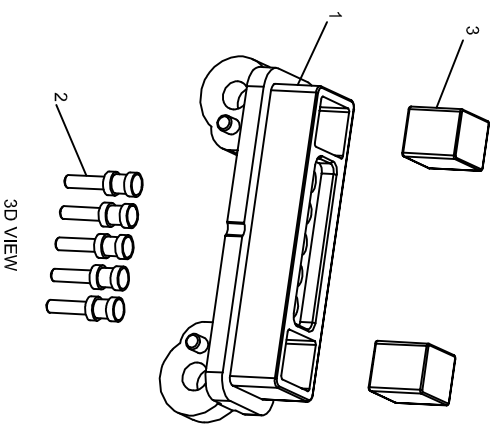
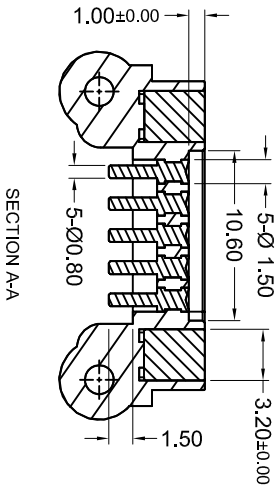
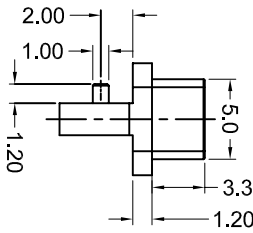
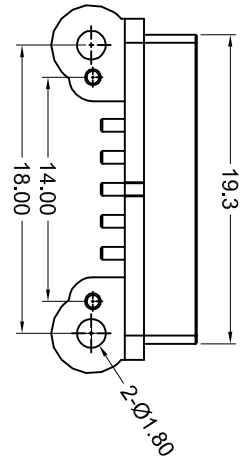
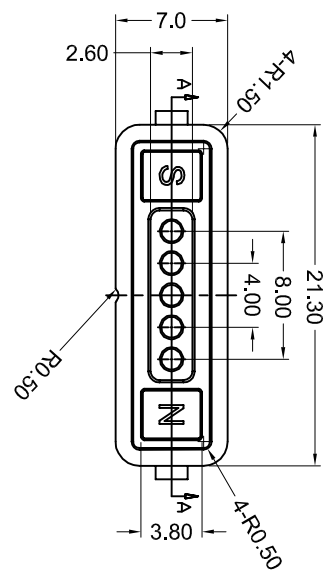

SPECIFICATION:

VOL TAGE RATING: 5 V  
 CURRENT RATING: 2A  
 INSULATION RESISTANCE: 100MEGAOHM MIN  
 DIELECTRIC WITHSTANDING VOLTAGE: 100V AT 60HZ  
 CONTACT RESISTANCE: 30 MOHMS MAX. BEFORE TEST AND  
 60MOHMS MAX. AFTER TEST  
 SALT SPRAY TEST: 5% SALT SPRAY CONCENTRATION, TEMPERATURE 35°C,  
 TEST TIME 48 HOURS, NO CORROSION  
 OPERATING TEMPERATURE: -30°C-85°C

POGO CONNECTOR, 5 POS, FEMALE

ACAD REFERENCE NO.: M00-PG0-205-103		SHEET 1 OF 1	
DRAWN: E.S	DATE: JUN 6/2022	ISSUE	
CHECKED: R.S.M.	DATE: JUN 6/2022	1	
SCALE: (IN C.A.D. 1:1)		DRAWING NUMBER: M00-PG0-205-103	
		PART NUMBER: M00-PG0-205-103	



THIS SERIES FULLY CONFORMS TO  
THE EUROPEAN UNION DIRECTIVES  
2011/65/EU FOR ROHS COMPLIANCY.



EDAC INC  
TORONTO, ONTARIO  
CANADA

THESE DRAWINGS AND SPECIFICATIONS  
ARE THE PROPERTY OF EDAC INC. AND  
SHALL NOT BE REPRODUCED OR COPIED  
OR USED AS THE BASIS FOR THE  
MANUFACTURE OR SALE OF APPARATUS  
WITHOUT WRITTEN PERMISSION.

YOUR CONNECTION TO QUALITY & SERVICE