

REVISIONS

NOTE:

- 1 MOUNTING: 2x SLOT 5x10mm
- 2 TERMINATION CABLES: UL APPROVED FEP CABLES FOR THE TERMINATIONS, BASED ON THE RESISTOR CURRENT RATING (SEE CHART BELOW) WITH E5 RING TERMINALS

CURRENT RATING	CABLE SIZE USED
≤15A	16 AWG
>15A & ≤25A	14 AWG
>25A & ≤35A	12 AWG

3 FOR FURTHER INFORMATION SEE DATA SHEET FOR CJP SERIES OF ALUMINIUM HOUSED RESISTOR

P	LTR	DESCRIPTION	DATE	DWN	APVD
	A	INITIAL DRAWING RELEASE	27MAY2022	KS	AP

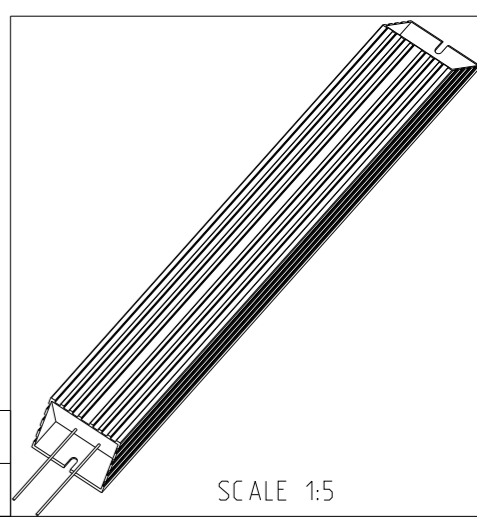
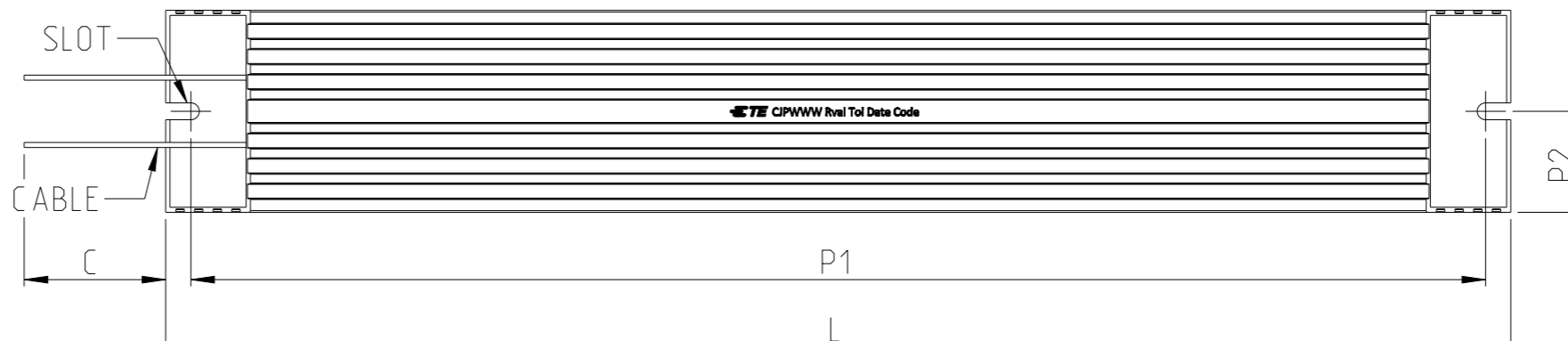
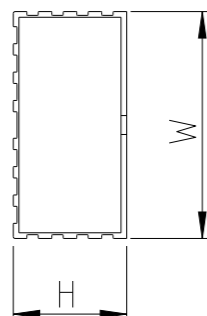

PART NUMBER	L	W	H	C	P1	P2
CJP1000	400	60	30	290	385	30

THIS DRAWING IS A CONTROLLED DOCUMENT.

DWN KARTHIK S 27MAY2022

CHK ALLAN P 27MAY2022

APVD ALLAN P 27MAY2022

PRODUCT SPEC

APPLICATION SPEC

WEIGHT

CUSTOMER DRAWING



NAME
ALUMINIUM ENCLOSED RESISTOR
CJP1000 SERIES

SIZE	CAGE CODE	DRAWING NO	RESTRICTED TO
A3	00779	C=2176513	-

DIMENSIONS:	TOLERANCES UNLESS OTHERWISE SPECIFIED:
mm	
	0 PLC ±-
	1 PLC ±0.5
	2 PLC ±0.13
	3 PLC ±0.013
	4 PLC ±0.0001
	ANGLES ±
MATERIAL	FINISH
-	-
-	-

