

Leiterplatten-Layout Vorschlag für SMT  
PCB-Layout Proposal for SMT

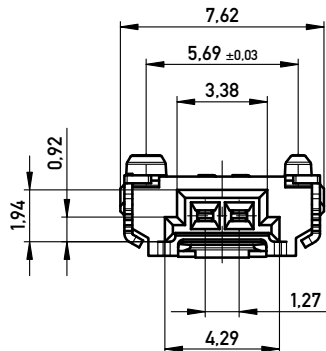
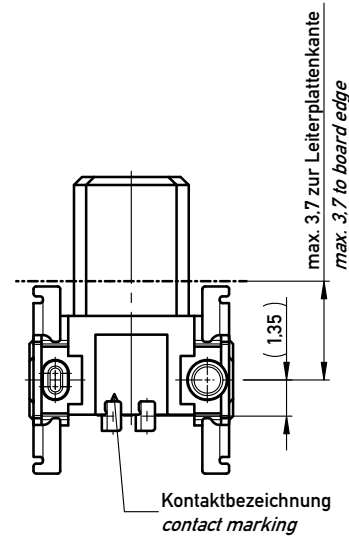
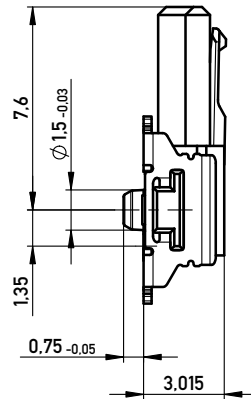
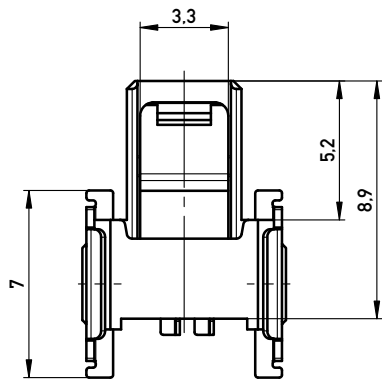
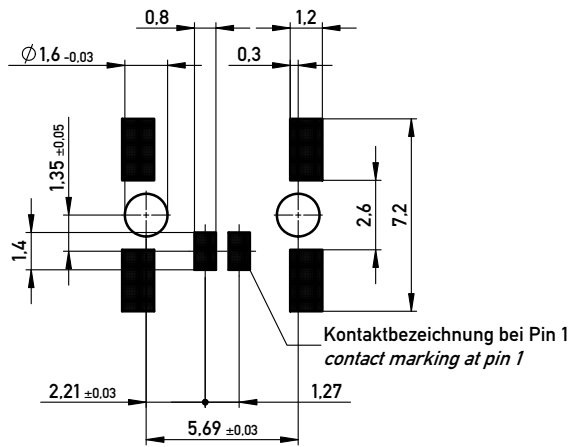

Anforderungsstufe 1  
Performance Level 1

Kontaktbereich vergoldet  
Mating Area gold plating

Anschlussbereich verzinkt 4-6 µm  
Terminal Area 4-6 µm tin plating

Koplanarität der Anschlüsse ≤ 0.1 mm  
Coplanarity Area of Termination ≤ 0.1 mm

Verpackt im Gurt in Anlehnung an DIN IEC 60286-3  
Tape on Reel Packaging according to DIN IEC 60286-3  
Verpackungseinheit: 850 Stück  
Packaging unit: 850 pcs

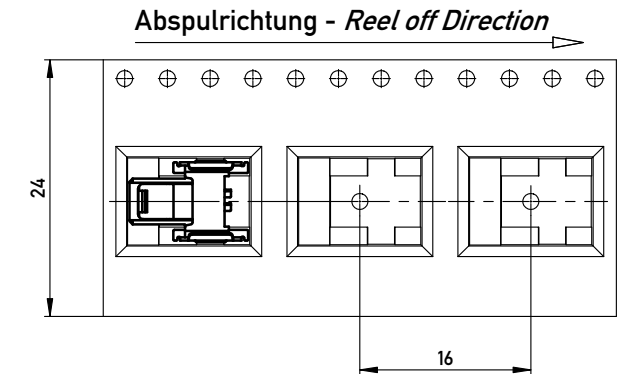
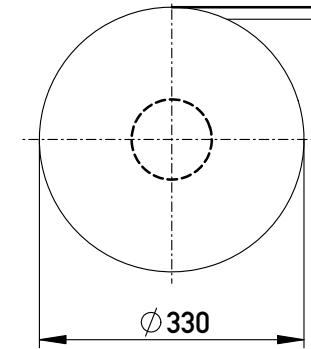

mit Verriegelung  
with locking mechanism

Information: ohne Hilfsmittel lösbar, Bauteilfarbe: schwarz without tool unlockable, component color: black	Tolerances	All Dimensions in mm	Scale	5:1
			Designation	F 1.27 SRC P, 2-polig BA1
All rights reserved. Only for Information. To ensure that this is the latest version of this drawing, please contact one of the ERNI companies before using.	Subject to modification without prior notice. Drawing will not be updated.		www.ERNI.com	
			384845	
a	14.07.2015			I
Index	Date		Class	A3
			Class	SRCP