

P	LTR	DESCRIPTION	DATE	DWN	APVD
	A	NEW DRAWING	06MAR2021	CK	JB

1. TRAY PACKAGING

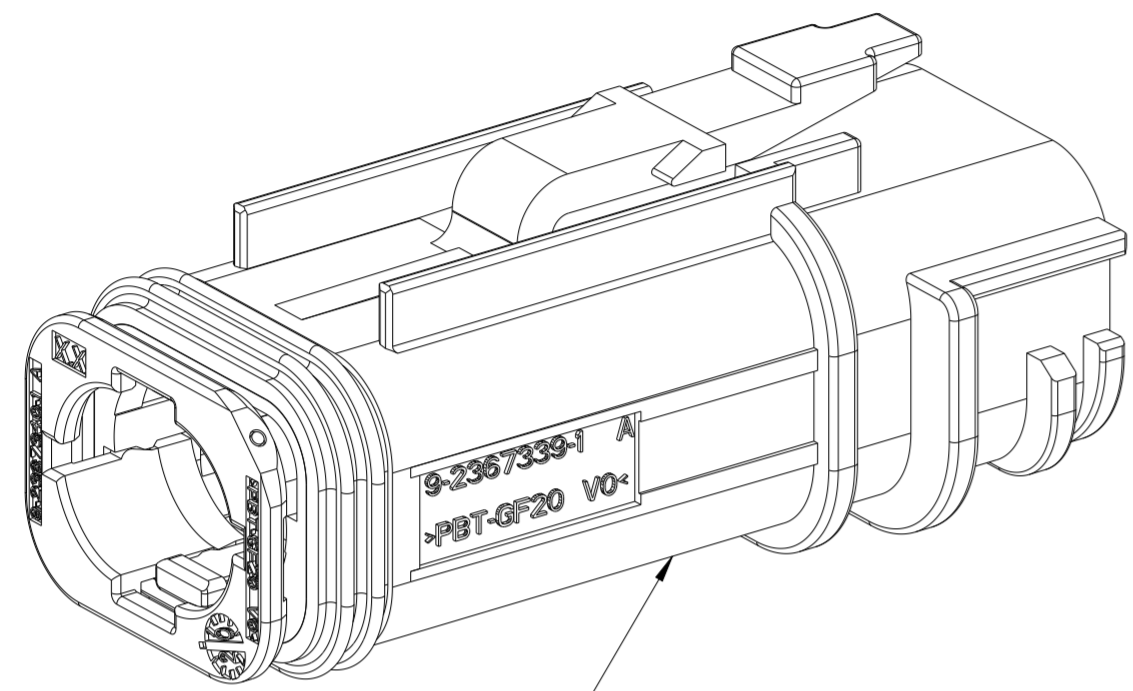

9-2367337-1
DT Highspeed Plug Assembly

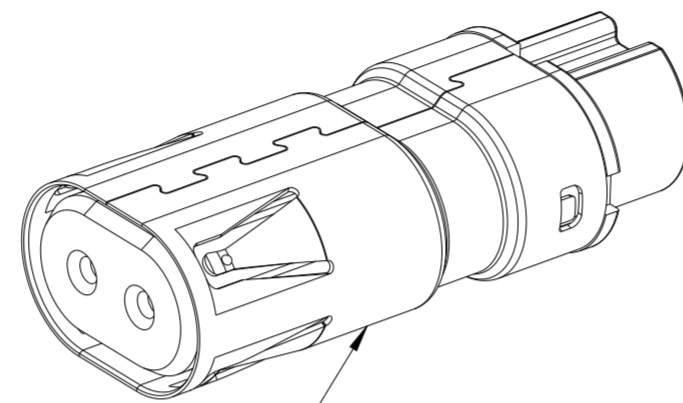

9-2370714-1
DT Highspeed Terminal-Plug

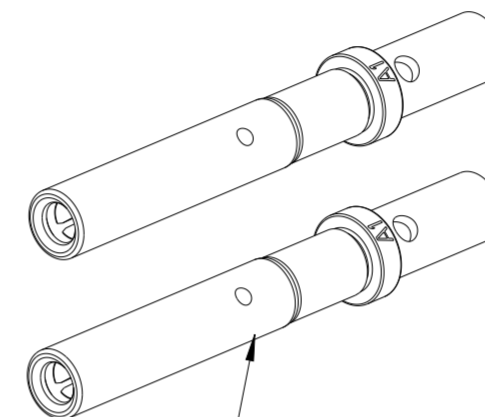

0462-201-2031
Contact Socket, Size 20, 20AWG

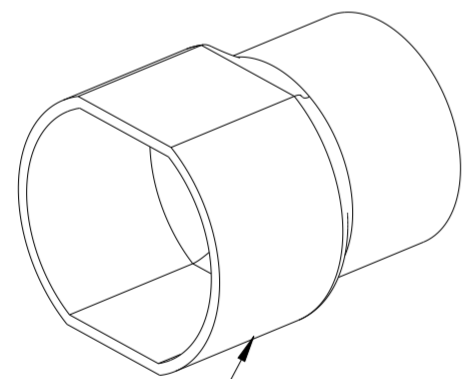

9-2370624-1
DT Highspeed Ferrule

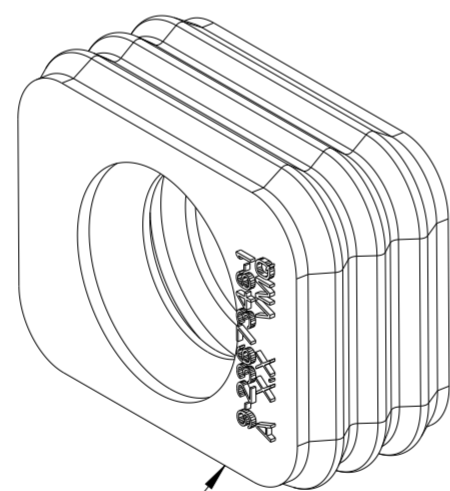

9-2367346-1
DT Highspeed Single Wire Seal

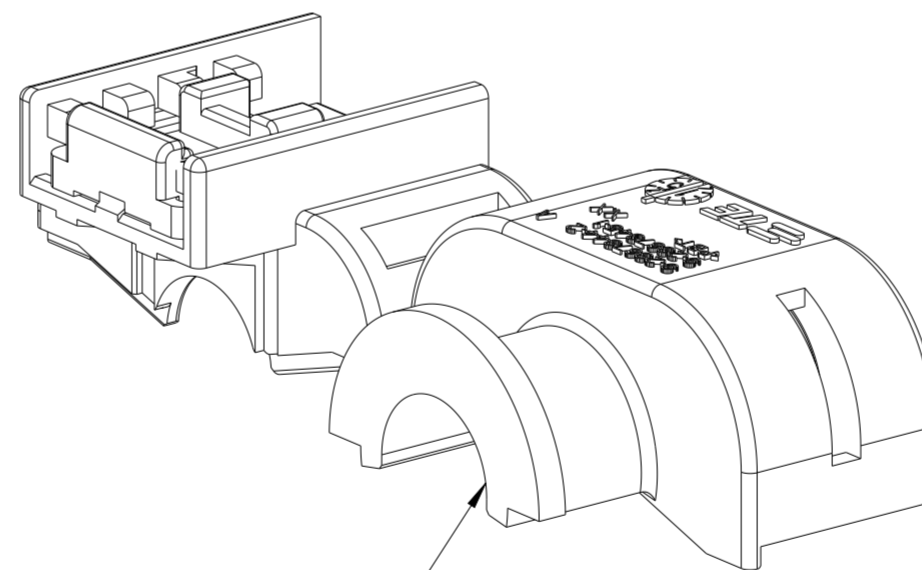

9-2367345-1
DT Highspeed Cover Assembly

QTY	PART/TCPN NO.	REV.	DESCRIPTION	ITEM NO.
1	9-2367345-1	A	DT Highspeed COVER Assembly	6
1	9-2367346-1	A	DT Highspeed Single wire seal	5
1	9-2370624-1	A	DT Highspeed Ferrule	4
2	0462-201-2031	F	Contact Socket, Size 20, 20AWG	3
1	9-2370714-1	A	DT Highspeed Inner HSG-Plug	2
1	9-2367337-1	B	DT Highspeed Plug Assembly	1
9-2386764-1		PART/TCPN NO.	DESCRIPTION	ITEM NO.
A		REVISION OF EACH ASSY NO (WHEN BLANK, USE DWG REVISION)		
51.4		WEIGHT OF EACH ASSY NO [g]		
QTY REQD PER ASSY TPCN		PARTS LIST		

THIS DRAWING IS A CONTROLLED DOCUMENT.

DIMENSIONS:	TOLERANCES UNLESS OTHERWISE SPECIFIED:
mm	0 PLC ±
	1 PLC ±
	2 PLC ±
	3 PLC ±
	4 PLC ±
	ANGLES ±
MATERIAL	FINISH
-	-
-	-

DWN	06MAR2021
CHK	08MAR2021
APVD	09MAR2021
PRODUCT SPEC	108-94825
APPLICATION SPEC	114-94706
WEIGHT	-
CUSTOMER DRAWING	

STE TE Connectivity

NAME: DT Highspeed Connector Kit

SIZE: A2 CAGE CODE: 00779 DRAWING NO: C-2386764 RESTRICTED TO: -

SCALE: 5:1 SHEET: 1 OF 2 REV: A

P	LTR	DESCRIPTION	DATE	DWN	APVD
-	-	SEE SHEET 1	-	-	-

1. TRAY PACKAGING

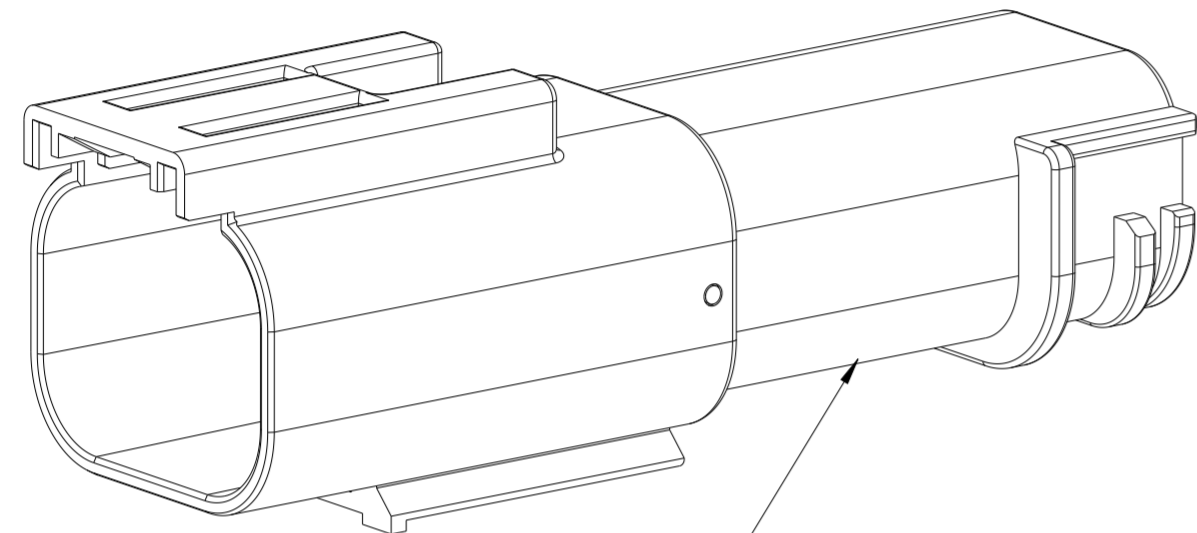

9-2367341-1
DT Highspeed TAB Assembly

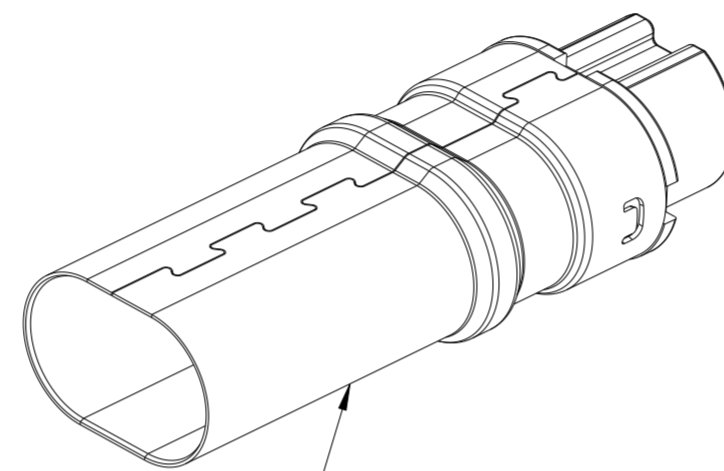

9-2370710-1
DT Highspeed Terminal-Tab

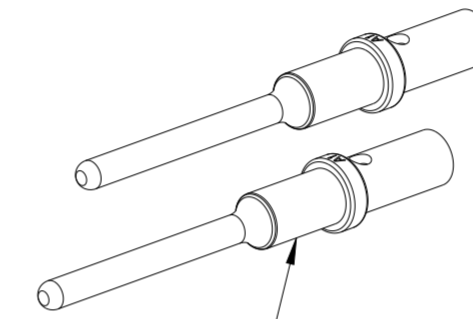

0460-202-2031
Contact Pin, Size 20, 20AWG

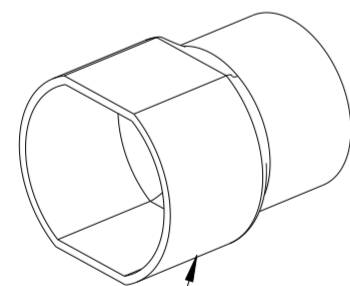

9-2370624-1
DT Highspeed Ferrule

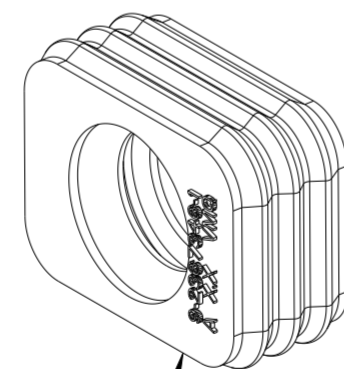

9-2367346-1
DT Highspeed Single Wire Seal

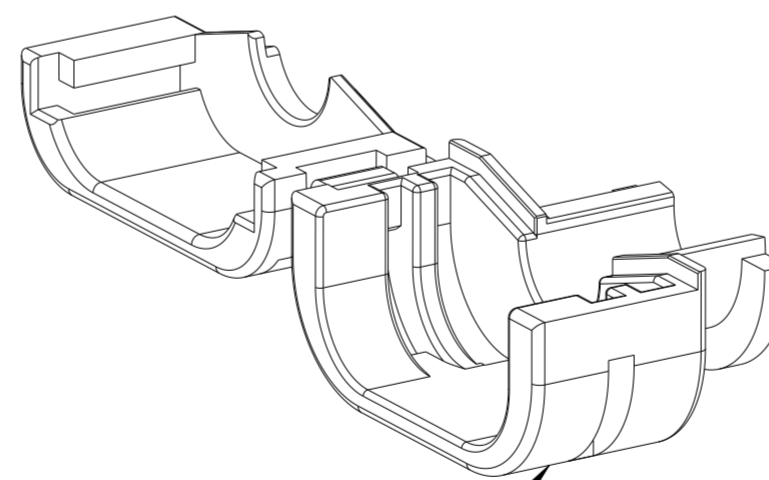

9-2367344-1
DT Highspeed Cover

QTY REQD PER ASSY	TCPN	REV.	DESCRIPTION	ITEM NO.
1	9-2367344-1	A	DT Highspeed COVER	6
1	9-2367346-1	A	DT Highspeed Single wire seal	5
1	9-2370624-1	A	DT Highspeed Ferrule	4
2	0460-202-2031	A	Contact Pin, Size 20, 20AWG	3
1	9-2370710-1	A	DT Highspeed Inner HSG-Tab	2
1	9-2367341-1	A	DT Highspeed TAB Assembly	1
9-2386764-2		PART/TCPN NO.	DESCRIPTION	ITEM NO.
A		REVISION OF EACH ASSY NO (WHEN BLANK, USE DWG REVISION)		
14.48		WEIGHT OF EACH ASSY NO [g]		
QTY REQD PER ASSY TCPN		PARTS LIST		

THIS DRAWING IS A CONTROLLED DOCUMENT.

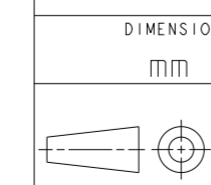

MATERIAL
-

TOLERANCES UNLESS OTHERWISE SPECIFIED:
0 PLC ±
1 PLC ±
2 PLC ±
3 PLC ±
4 PLC ±
ANGLES ±
FINISH -

DWN 06MAR2021
CHK CHANDRAKANTH
H. SEBASTIAN
APVD 08MAR2021
J. BARTH
09MAR2021
PRODUCT SPEC
108-94825
APPLICATION SPEC
114-94706
WEIGHT -
CUSTOMER DRAWING



DT Highspeed Connector Kit

SIZE A2 CAGE CODE 00779 DRAWING NO. C-2386764 RESTRICTED TO -
SCALE 5:1 SHEET 2 OF 2 REV A